

Contents

A-Z

Owner's Handbook
for the Vehicle



The Ultimate Driving
Machine



THE BMW X3. OWNER'S HANDBOOK.

BMW EfficientDynamics
Less emissions. More driving pleasure.

X3 xDrive20i
X3 xDrive28i
X3 xDrive35i
X3 xDrive20d
X3 xDrive30d
X3 xDrive35d

Owner's Handbook for Vehicle

Congratulations on your choice of a BMW.

The better you are acquainted with your car, the easier you will find it is to handle. We would therefore like to offer you the following advice:

Please read the Owner's Handbook before setting out in your new BMW. Also use the integrated Owner's Handbook in your vehicle. It contains important notes on how to operate the car, enabling you to derive maximum benefit from the technical advantages of your BMW. It also contains useful information which will help you to uphold both your BMW's operating safety and its full resale value.

Updates to the printed or integrated Owner's Handbook after going to press are located as needed in the appendix to the printed quick reference to the vehicle.

Supplementary information is provided in the other documents of on-board literature.

We wish you a safe and enjoyable journey,

BMW AG

© 2012 Bayerische Motoren Werke
Aktiengesellschaft
Munich, Germany
Not to be reproduced, wholly or in part, without written
permission from BMW AG, Munich.
English II/12, 03 12 490
Printed on environmentally friendly paper, bleached
without chlorine, suitable for recycling.

Contents

For quick access to a particular topic or item, please consult the detailed alphabetical index, see page 302.

6 Notes

Overview

10 Cockpit
14 iDrive
21 Voice control system
24 Integrated Owner's Handbook in the vehicle

Controls

28 Opening and closing
44 Adjusting
54 Carrying children in safety
59 Driving
71 Displays
86 Lights
92 Security
99 Driving stability control systems
105 Driving comfort
118 Climate
125 Interior equipment
131 Storage compartments

Driving hints

138 Driving precautions
142 Loads
144 Towing a trailer
148 Saving fuel

Navigation

154 Navigation system

Entertainment

174 Sound
176 Radio
181 CD/multimedia

Communication

208 Telephone
218 Office
227 Contacts
230 ConnectedDrive
239 Extended BMW Online services

Mobility

242 Refuelling
244 Fuel
246 Wheels and tyres
254 Engine compartment
256 Engine oil
259 Coolant
260 Maintenance
263 Replacing parts
271 Help in the event of a breakdown
277 General care

Reference

284 Technical data
293 Short commands of the voice control system
302 From A to Z

Notes

About this Owner's Handbook

The quickest access to a particular topic or item is by consulting the alphabetical index.

The first chapter is recommended for an initial overview of the vehicle.

Updates after going to press

Updates to the Owner's Handbook after going to press are found in the appendix of the printed quick reference to the vehicle.

Additional sources of information

Should you require any further information, please contact your Service centre, who will be pleased to advise you.

Information on BMW, for example on technology, on the Internet: www.bmw.com

Symbols

 Indicates precautions that must be followed precisely in order to avoid the possibility of personal injury and serious damage to the vehicle.

◀ Marks the end of a specific item of information.

"..." Identifies texts on the control display for selecting functions.

>...< Identifies commands for the voice control system.

>...<< Identifies replies by the voice control system.

 Refers to measures that can be taken to help protect the environment.

Symbol for components and assemblies

 Recommends that you study the relevant section of this Owner's Handbook in connection with a particular part or assembly.

Vehicle Equipment

This Owner's Handbook describes all models and all standard, national and special equipment provided in the model series. This Owner's Handbook therefore also describes and illustrates equipment not present in your vehicle, for example due to selected special equipment and national version.

That also applies to safety-relevant functions and systems.

If certain equipment and models are not described in this Owner's Handbook, refer to the Supplementary Owner's Handbooks provided.

In right-hand drive vehicles, some of the control functions are arranged differently from those shown in the illustrations.

Built-date

The 'built-date' of your vehicle is indicated underneath the door post on the driver's door.

The 'built-date' is defined as 'the calendar month and the calendar year in which the body shell and the powertrain subassemblies are conjoined and the vehicle is driven or moved from the production line'.

Status of the Owner's Handbook

The high level of safety and quality of vehicles is ensured by continuous enhancement. In rare in-

stances, your car may therefore differ from the information supplied here.

For Australia/New Zealand

When reading this Owner's Handbook, please bear the following in mind: to ensure that our vehicles continue to embody the highest quality and safety standards, we pursue a policy of continuous, ongoing development. Because modifications in the design of both vehicles and accessories may be introduced at any time, your own vehicle's equipment may vary from that described in this manual. For the same reason, it is also impossible to guarantee that all descriptions will be completely accurate in all respects.

We must therefore request your understanding of the fact that the manufacturer of your vehicle is unable to recognise legal claims based on discrepancies between the data, illustrations and descriptions in this Owner's Handbook and your own vehicle's equipment. Please note, too, that some of the optional equipment described in this manual is not available on Australian models due to restrictions imposed by Australian Design Rules and other requirements.

Should you require any further information, please contact your Service centre, who will be pleased to advise you.

Updates after going to press

Updates to the Owner's Handbook after going to press are found in the appendix of the printed quick reference to the vehicle.

Your own safety

Your vehicle is configured for the operating conditions and registration requirements of your country. If the vehicle is to be operated in another country, your vehicle must be adapted to any prevailing different operating conditions and permit requirements. Information on possible exclusion of warranty or warranty restrictions for your vehicle can be obtained from your Service centre.

Maintenance and repair

The advanced technology behind this car, for example the use of modern materials and high-performance electronics, means that adapted methods of maintenance and repair are required.

Always have the corresponding work performed either by a BMW Service centre or by a workshop that operates to BMW specifications and has suitably trained personnel.

If such work is performed inexpertly, it could result in consequential damage and thus constitute a safety risk.

Parts and accessories

BMW recommends using parts and accessory products that are specifically approved for this purpose by BMW.

You are recommended to consult a BMW Service centre for advice on genuine BMW parts and accessories, other BMW approved products and competent advice on all related matters.

The safety and compatibility of these products in conjunction with BMW vehicles have been checked by BMW.

BMW accepts product liability for them. BMW cannot accept liability for parts or accessory products of any kind which it has not approved.

BMW is unable to assess each individual product of outside origin as to its suitability for use on BMW vehicles without safety risk. Nor can suitability be assured if an official permit has been issued for it in a specific country. Tests performed for such permits cannot always cover all operating conditions for BMW vehicles, and some of them therefore are insufficient.



Overview

This summary of buttons, switches and displays serves as an initial guide.

In addition, it gives you an insight into the principles behind the various ways in which functions can be performed.

Cockpit

Vehicle Equipment

This chapter describes all standard, national and special equipment provided in the model series.

Therefore equipment not available in a vehicle is also described, for example the selected special equipment or national version. That also applies to safety-relevant functions and systems.

Around the steering wheel

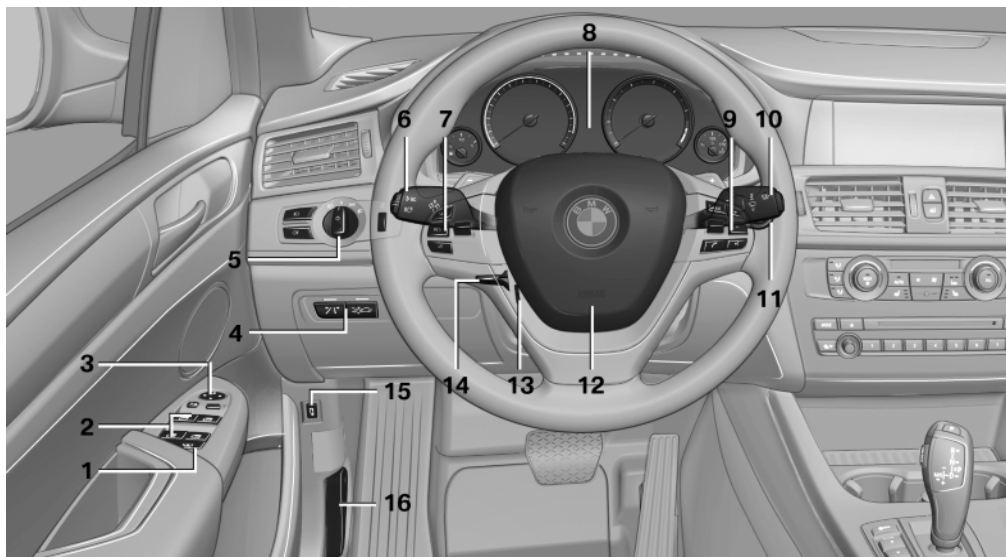

1 Safety switch for window in rear passenger compartment 41

2 Power windows 40

3 Exterior mirror operation 51

4  Lane departure warning 97

 Forward alert 105

5 Lights



Front fog lights 90

























Rear fog lights 90



Side lights 86



Low-beam headlights 86

-  Automatic driving lights control [87](#)
 Daytime driving lights [87](#)
 Adaptive Headlights [88](#)
 High-beam assistance [88](#)
-  Instrument lighting [90](#)
- 6** Steering-column lever, left
-  Turn indicator [65](#)
-  High-beam headlights, headlight flasher [65](#)
-  High-beam assistance [88](#)
-  Parking lights [87](#)
-  On-board computer [80](#)
- 7** Buttons on steering wheel, left
-  Set speed [107](#)
-  Resume speed [108](#)
-  Cruise control on/off, interrupt [107](#)
- Paddle for Cruise Control [80](#)
- 8** Instrument cluster [71](#)
- 9** Buttons on steering wheel, right
-  Entertainment source
-  Volume control
-  Voice control [21](#)
-  Telephone [208](#)
- Knurled wheel for selection lists [107](#)
- 10** Steering-column lever, right
-  Windscreen wipers [66](#)
-  Rain sensor [66](#)
-  Cleaning the windows and headlights [67](#)
-  Rear wipers [67](#)
- 11**  Start/stop engine and switch ignition on/off [60](#)
-  Auto Start Stop function [61](#)
- 12** Horn
- 13**  Steering wheel heating [53](#)
- 14** Steering wheel adjustment [53](#)
- 15**  Opening the tailgate [35](#)
- 16** Unlock bonnet [254](#)

Around the centre console

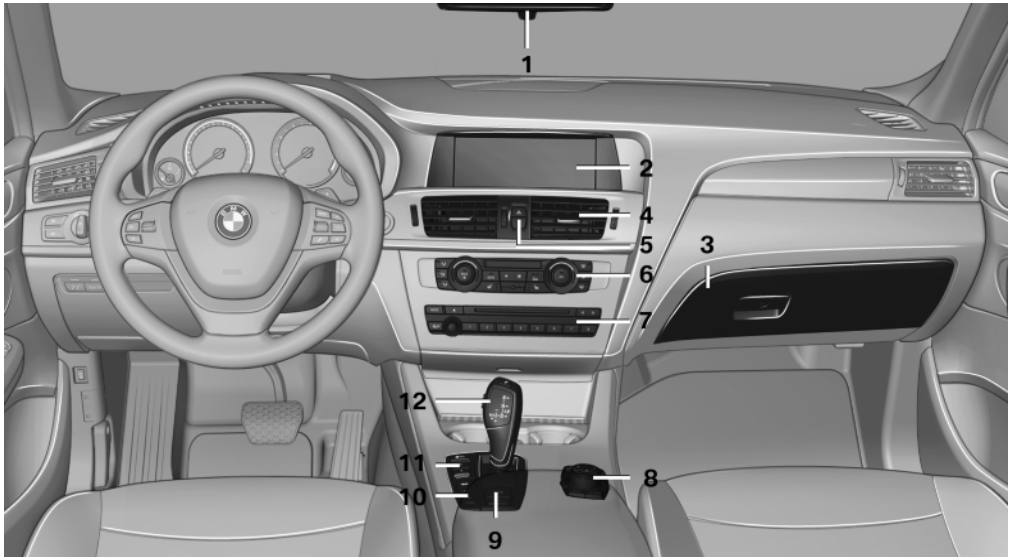



1 Roof lining [13](#)

2 Control display [14](#)

3 Glove box [131](#)

4 Air outlets [123](#)

5  Hazard warning flashers [271](#)

 Central locking system [31](#)

6 Automatic air conditioning [118](#)

7 Radio [176](#)

CD/multimedia [181](#)

8 Controller with buttons [14](#)

9  Parking brake [63](#)

 Auto Hold [64](#)

10  Park Distance Control, PDC [109](#)

Rear view camera [111](#)

Top View [114](#)

 Hill Descent Control HDC [100](#)

11  Drive experience switch [102](#)





 Dynamic Stability Control, DSC [99](#)

12 Manual gearbox [68](#)

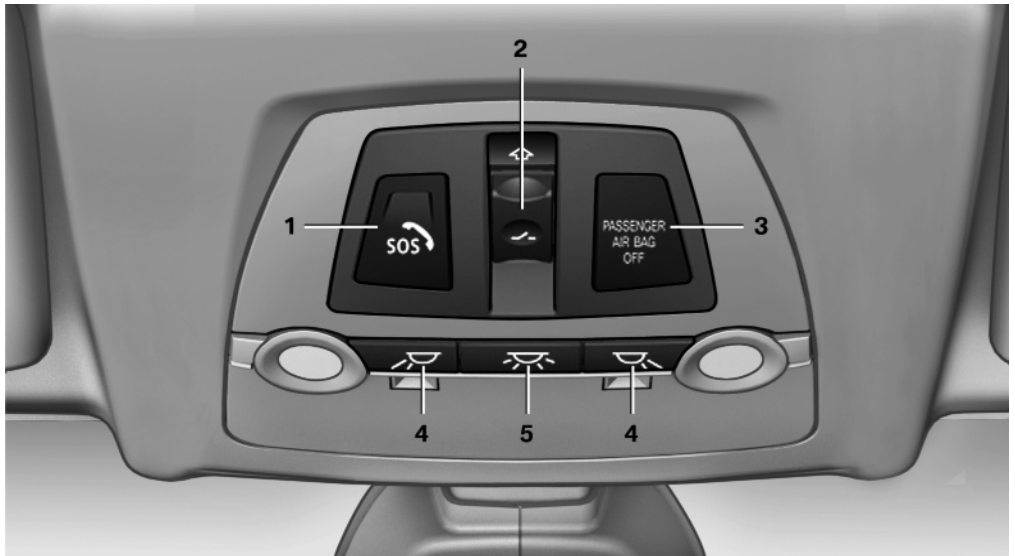
Automatic transmission [68](#)

Around the headlining



- | | | | | | |
|---|---|--|---|---|-----------------------------------|
| 1 |  | Emergency call 271 | 4 |  | Reading lights 91 |
| 2 |  | Panorama glass roof 41 | 5 |  | Interior light 90 |
| 3 |  | Front passenger airbag indicator lamp 94 | | | |

iDrive

Vehicle Equipment

This chapter describes all standard, national and special equipment provided in the model series. Therefore equipment not available in a vehicle is also described, for example the selected special equipment or national version. That also applies to safety-relevant functions and systems.

Principle

iDrive integrates the functions of a large number of switches. These functions can thus be controlled from one central point.

 Operate iDrive while the vehicle is in motion

Only make adjustments if the traffic conditions are appropriate. Otherwise, you may become distracted and endanger the vehicle occupants and other road users. ◀

Overview of controls

Control functions

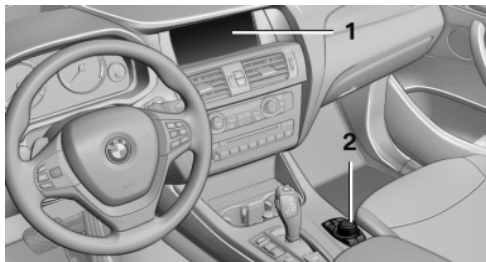

- 1 Control display
- 2 Controller with buttons

The buttons can be used to call up menus directly. The controller can be used to select menu items and make settings.

Control display

Notes

- ▶ To clean the control display, comply with the information regarding care.
- ▶ To avoid risk of damage to the control display, please do not place objects in front of it.

Switching off

1.  Press the button.
2. "Switch off control display"

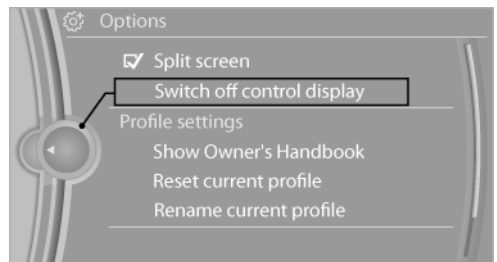

Switch on

Press the controller to switch on.

Controller

Select menu items and making settings.

1. Turning.

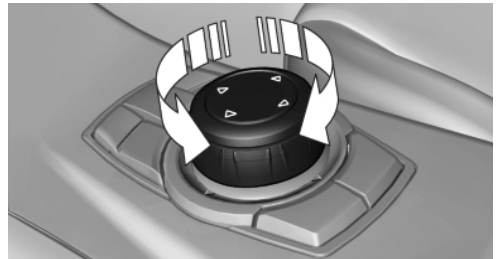

2. Pressing.

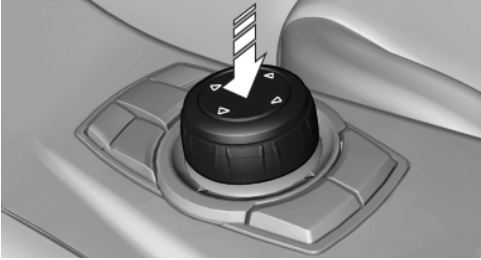

3. Tilting in four directions.

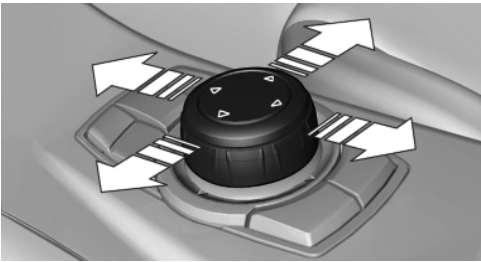

Buttons on the controller

Press the button	Function
MENU	Call up the main menu.
RADIO	Calls up the Radio menu.
CD	Calls up the CD/multimedia menu.
NAV	Calls up the Navigation menu.
TEL	Calls up the Telephone menu.
BACK	Displays the previous screen.
OPTION	Calls up the Options menu.

Operating principle

Calling up the main menu

 Press the button.

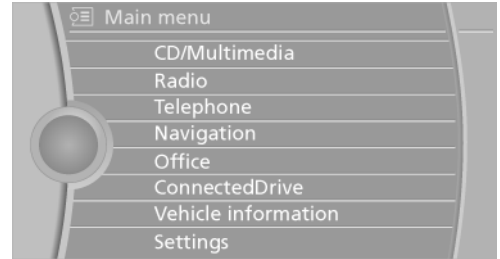

The main menu is displayed.

All iDrive functions can be called up via the main menu.

Selecting a menu item

Menu items in white can be selected by highlighting them.

1. Turn the controller until the desired menu item is highlighted.

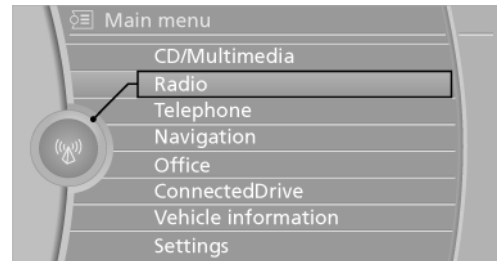

2. Press the controller.

Menu items in the Owner's Handbook

In this Owner's Handbook, the menu items that are to be selected are shown in quotation marks, for example "Settings".

Switching between screens

After a menu item has been selected, for example "Radio", a new screen is displayed. Screens can lie one on top of the other.

- ▶ Tilt the controller to the left.

The current screen is closed and the previous screen is displayed.

Pressing the BACK button reopens the previous screen. The current screen is not closed.

- ▶ Tilt the controller to the right.

A new screen is opened and overlaid.

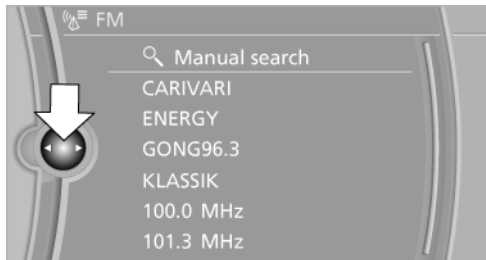

White arrows to the left or right indicate that other screens can be called up.

View of an opened menu

In general, when a menu is called up, the screen that was last selected in this menu is displayed. To display the first screen of the menu:

- ▶ Tilt the controller repeatedly to the left until the first screen is displayed.
- ▶ Press the menu button on the controller twice.

Calling up the Options menu

 Press the button.

The "Options" menu is displayed.



Alternatively, tilt the controller repeatedly to the right until the "Options" menu is displayed.

Options menu

The "Options" menu consists of various areas:

- ▶ Screen settings, for example "Split screen". Area remains unchanged.
- ▶ Operating options for the selected main menu, for example for "Radio".
- ▶ If applicable, other operating options for the selected main menu, for example "Save station".

Adjusting the settings

1. Select a field.
2. Turn the controller until the desired setting is displayed.

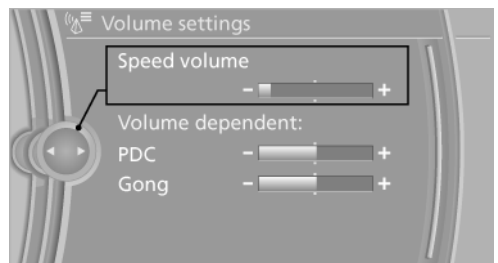

3. Press the controller.

Enabling/disabling functions

Some menu items are preceded by a checkbox. This indicates whether the function is enabled or disabled. Selecting the menu item enables or disables the function.

Function is enabled.

- ❑ Function is disabled.

Example: setting the clock

Setting the clock

1.  Press the button. The main menu is displayed.
2. Turn the controller until "Settings" is highlighted and press the controller.

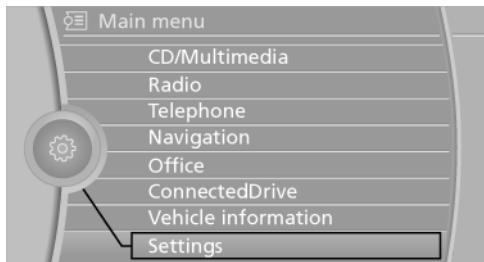

3. If necessary, tilt the controller to the left to display "Time/Date".
4. Turn the controller until "Time/Date" is highlighted and press the controller.



5. Turn the controller until "Time:" is highlighted and press the controller.

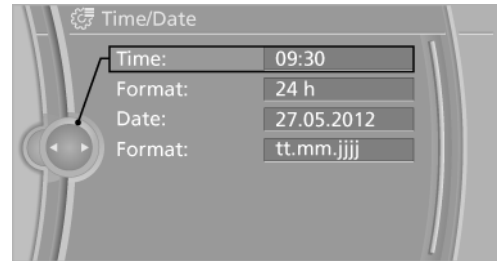

6. Turn the controller to set the hour and press the controller.
7. Turn the controller to set the minutes and press the controller.

Status information

Status field

The following items of information are displayed in the status field on the top right:

- ▷ Time
- ▷ Current entertainment source.
- ▷ Sound output on/off.
- ▷ Reception level of mobile telephone network.
- ▷ Phone status.
- ▷ Reception of traffic reports.













Symbols in the status field

The symbols are combined in the following groups.







Symbols for radio

Symbol	Meaning
TP	Traffic Information switched on.

Symbols for telephone

Symbol	Meaning
	Incoming or outgoing call.
	Missed call.
	Reception level of mobile telephone network symbol flashes: network search.
	No mobile phone network available.
	Bluetooth switched on.
	Data transfer active.
	Roaming active.
	Text message received.
	SIM card check.
	SIM card disabled.
	SIM card not found.
	PIN required.

Symbols for entertainment

Symbol	Meaning
	CD/DVD player.
	Music collection
	Gracenote® database.
	AUX-IN port
	USB audio interface/Audio interface, mobile phone
	USB audio interface.
	Audio interface for mobile phone.

Other functions

Symbol	Meaning
	Spoken instructions switched off.

Split screen

General

In the split screen view, additional information can be displayed on the right-hand side of the screen, for example information from the on-board computer.

This information remains visible in the split screen view even if a switch is made to another menu.

Switching the split screen view on and off

-  Press the button.
- "Split screen"

Selecting display

-  Press the button.
- "Split screen"
- Tilt the controller until the split screen is selected.
- Press the controller or select "Split screen display"
- Select the desired menu item.

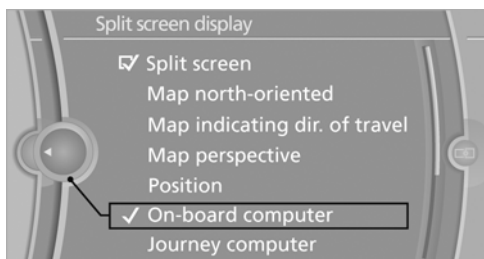

Favourites buttons

General



iDrive functions can be saved on the favourites buttons and called up directly, for example radio stations, navigation destinations, telephone numbers and shortcuts into the menu.

The settings are saved for the remote control currently in use.

Saving a function

1. Highlight the function using the iDrive.
2.  Press the desired button for longer than 2 seconds.

Performing a function

1.  Press the button.
2.  The function is carried out immediately. If you have selected a telephone number, for example, the connection will also be established.

Displaying assignment of buttons

Touch the buttons with your finger. Do not wear gloves or use objects.

The assignment of the buttons is displayed at the top edge of the screen.

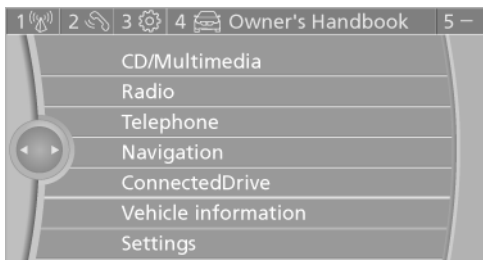

- ▶ To display brief information: touch the button.
- ▶ To display detailed information: touch the button for longer.



Clearing assignment of buttons

1. Press buttons 1 and 8 simultaneously for approximately five seconds.
2. "OK"

Entering letters and digits

General

1. Turn controller and select letters or digits.
2. If applicable, select other letters or digits.
3. Select "OK" to confirm the input.

Symbol	Function
	Press the controller: deletes a letter or digit.
	Press and hold down the controller: deletes all numbers or letters.
	Enters a space.

Change between upper/lower case, numbers and symbols

Depending on the menu, you can switch between the input of lower case or upper case letters, numbers and symbols:

Symbol	Function
A^BC	Enter letters.
1@+	Enter digits.
abc or ABC	Tilt the controller up.

Entry comparison

Input of names and addresses: the selection is gradually narrowed down and possibly supplemented with every subsequent letter that you enter.

Inputs are continuously compared with the data saved in the vehicle.

- ▶ Only letters that are present in the data are offered for entry.

- ▷ Destination search: place names can be entered in the writing of any language available on the control display.

Voice control system

Vehicle Equipment

This chapter describes all standard, national and special equipment provided in the model series. Therefore equipment not available in a vehicle is also described, for example the selected special equipment or national version. That also applies to safety-relevant functions and systems.

Principle

- ▶ Through the voice control system most functions shown in the Control Display can be operated by spoken commands. The system supports spoken input.
- ▶ Functions that can only be used when the vehicle is stationary cannot be operated via the voice control system.
- ▶ The system has a special microphone on the driver's side.
- ▶ ›...‹ Identifies commands for the voice control system in the Owner's Handbook.

Requirements

On the control display set a language that is also supported by the voice control system, so that the vehicle can identify spoken commands.

Setting the language, see page 84.

Issuing voice commands

Activating the voice control system

1.  Press the button on the steering wheel.
2. Wait for acoustic signal.
3. Issue the command.

The command is shown in the instrument cluster.

 Symbol in the instrument cluster indicates that the voice control system is active.

If no further spoken commands are possible, switch to iDrive to control the function in this case.

Switching off the voice control system



Press the button on the steering wheel or say ›Cancel‹.

Possible commands

Most of the menu items on the control display can be called up by means of spoken commands.

The possible commands depend on which menu is currently displayed on the Control Display.

There are commands for the functions of the main menu.

Several list entries, for example, telephone book entries, can also be selected using the voice control system. When doing this, list entries are to be spoken exactly as they are shown in the relevant list.

Having possible commands read aloud

Possible commands can be read aloud: ›Voice commands‹

If, for example, the menu "Settings" is displayed, the commands for the settings are announced.

Running functions using short commands

Main menu functions can be performed immediately using short commands, almost irrespec-

tive of which menu item is selected, for example ›Vehicle status.

List of Short commands of the voice control system, see page 293.

Help dialogue to voice entry system

Call up help dialogue: ›Help

Further commands for help dialogue:

- ▷ ›Help with examples: information on the current possible operations and the most important commands for this are read out.
- ▷ ›Help with voice input: information on the operating principle of the voice entry system is read out.

Example: playing a CD

1. If necessary, switch on entertainment audio output.
2.  Press the button on the steering wheel.
3. ›C D and multimedia
The last medium played is played.
4. ›C D track ..., for example CD track 4.

Setting the speech dialogue

You can set whether the system uses the standard dialogue or the short variant,

With the short variants of the speech dialogue, the system announcements are played in shortened form.

On the control display:

1. "Settings"
2. "Language/Units"

3. "Speech mode:"
4. Select the setting.

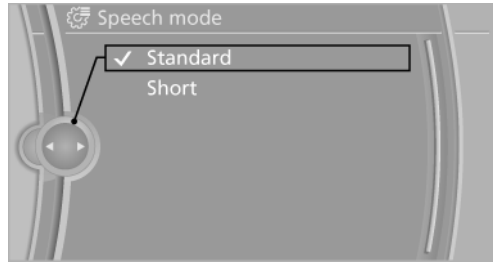

Adjusting volume

Turn the volume knob during the voice instructions until the desired volume is obtained.

- ▷ The volume is retained even if you change the volume of other audio sources.
- ▷ The volume is saved for the remote control currently in use.

Information regarding emergency calls

The voice control system should not be used for emergency calls. Under stress, the spoken language and voice pitch can change, which could unnecessarily delay the connection of your call. Instead, use the SOS button, see page 271, in the area of the interior mirror.

Operating conditions

- ▷ Commands, digits and letters should be pronounced fluently, with the usual emphasis, and at a normal volume and speed.
- ▷ Always speak the commands in the language of the voice control system.
- ▷ When selecting a radio station, use the standard pronunciation of the station name:

›Station ...‹ for example, Classic Radio station

- ▶ Doors, windows and the glass roof should be kept closed to avoid noise interference.
- ▶ Avoid background noises in the car while you are speaking.

Integrated Owner's Handbook in the vehicle

Vehicle Equipment

This chapter describes all standard, national and special equipment provided in the model series. Therefore equipment not available in a vehicle is also described, for example the selected special equipment or national version. That also applies to safety-relevant functions and systems.

Integrated Owner's Handbook in the vehicle

The integrated Owner's Handbook can be shown in the control display. It particularly describes the equipment and functions present in the vehicle.

Components of the integrated Owner's Handbook

The integrated Owner's Handbook consists of three parts, which provide various information depths or access possibilities.

Quick Reference

Important information is found in the quick reference for the operation of the vehicle, the operation of fundamental vehicle functions or in case of breakdown. This information can also be displayed when driving.

Search by pictures

Using the search by pictures, information and descriptions can be searched using pictures. For example, that is particularly helpful when the description of a piece of equipment is needed, which cannot be named.

Owner's Handbook

Here, information and descriptions can be searched via the index by directly entering a search term.

Select components

1.  Press the button.
2. Turn the controller and select "Vehicle information".
3. Press the controller.
4. Select desired area:
 - ▷ "Quick reference"
 - ▷ "Search by pictures"
 - ▷ "Owner's Handbook"

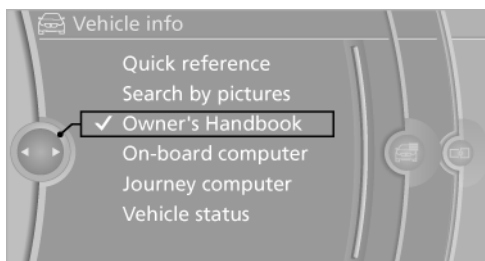

Browsing within the Owner's Handbook

Page by page with link access

Turn the controller until the next or previous page is displayed.

Page by page without link access

Browse the pages directly, skipping links.

Highlight the symbol once. Then simply press the controller to browse from page to page.



Browse back.



Browse forward.

Context-sensitive help - Owner's Handbook for the currently selected function

Suitable information can be displayed directly.

Call-up when operating via iDrive

Switch to the Options menu directly from the application on the control display:

1.  Press the button or tilt the controller repeatedly to the right until the "Options" menu appears.
2. "Show Owner's Handbook"

Calling up with display of a Check Control message

Directly from the Check Control message on the control display:

"Show Owner's Handbook"

Switching between function and Owner's Handbook

You can use the control display to switch from a function, for example radio, to the Owner's Handbook, and then back and forth between the two displays:

1.  Press the button or tilt the controller repeatedly to the right until the "Options" menu appears.
2. "Show Owner's Handbook"
3. Select the desired page in the Owner's Handbook.

4.  Press the button again to switch back to the last displayed function.

5.  Press the button again to switch back to the last displayed page of the Owner's Handbook.

To switch continuously between the last displayed function and the last displayed page of the Owner's Handbook, repeat steps 4 and 5. As you do so, new screens are opened.

Favourites buttons

General

The Owner's Handbook can be stored in the favourite buttons and called up directly.

Saving

1. Select "Owner's Handbook" using the iDrive.
2.  Hold down the desired button for longer than two seconds.

Use

1.  Press the button.
The Owner's Handbook is displayed immediately.



Controls

This chapter enables you to operate your car with greater ease, explaining in detail the features designed to make your journey safer, more comfortable and more enjoyable.

Opening and closing

Vehicle Equipment

This chapter describes all standard, national and special equipment provided in the model series. Therefore equipment not available in a vehicle is also described, for example the selected special equipment or national version. That also applies to safety-relevant functions and systems.

Remote control/keys

Buttons on the remote control

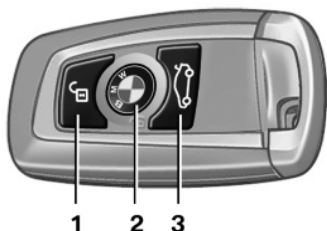

- 1 Unlocking
- 2 Locking
- 3 Opening the tailgate

General

The delivery specification includes two remote controls with keys.

Every remote control contains a replaceable battery.

The settings called up and implemented when the car is unlocked depend on which remote control is used to unlock the car. See Personal Profile, see page 29.

Information regarding service requirements is also saved in the remote control. See Service data in the remote control, see page 260.

Integrated key

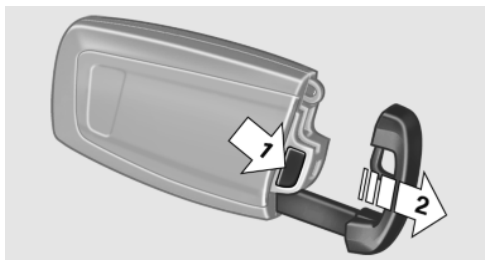

Press the button on the back of the remote control, arrow 1, and pull out the key, arrow 2.

The integrated key fits the following locks:

- ▷ Driver's door.
- ▷ Glove box on the passenger side.

Replacing the battery

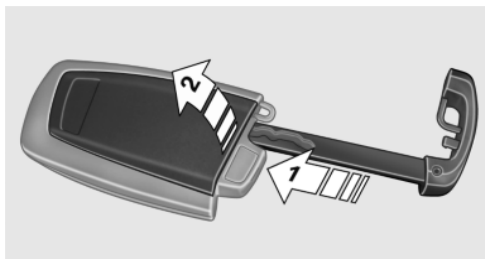

1. Remove the integrated key from the remote control.
2. Push in catch with the key, arrow 1.
3. Remove the cover for the battery compartment, arrow 2.
4. Insert a new battery of the same type with the positive side facing upwards.
5. Press the cover back into position.



Dispose of the old battery at an authorised collecting point or hand it in to a Service centre.

New remote controls

New remote controls can be obtained from your Service Centre.

Loss of remote controls

A lost remote control can be blocked by the Service Centre.

Emergency detection of the remote control

The ignition can be switched on or the engine started even in one of the following situations:

- ▷ Interference in the radio transmission to the remote control from external sources.
- ▷ Flat battery in the remote control.
- ▷ Fault in radio transmission due to mobile radio device in the immediate vicinity of the remote control.
- ▷ Fault in radio transmission due to the charger when charging in the vehicle, for example, for mobile radio devices.

If an attempt is made to switch on the ignition or start the engine, a Check Control message is displayed.

Starting the engine in the event of emergency detection of the remote control



Automatic gearbox: Hold the corresponding check control message of the remote control, as illustrated, to marking of the steering column and press the start/stop button within 10 seconds with the brake depressed.

Gearbox Hold the corresponding check control message of the remote control, as illustrated, to marking of the steering column and press the start/stop button within 10 seconds with the clutch depressed.

Personal Profile

Principle

Personal profile principle

Some functions of the vehicle can be adjusted to individual needs.

- ▷ Settings are saved automatically in the currently activated profile.
- ▷ When you unlock the vehicle, the last profile used with the remote control is recognised and called up.
- ▷ Personal settings are also found and called up if the vehicle has been driven in the meantime by other persons with their own remote controls.

Individual settings for three personal profiles and a guest profile are stored.

Transferring settings

The personal settings can be taken to another vehicle with the Personal Profile function. More detailed information is available from your Service centre.

The transfer takes place:

- ▷ Via the USB interface in the glove box or the centre console on a USB medium.
- ▷ Via BMW Online.

Profile management

Calling up profiles

Independently of the remote control that is used, another profile can be called up.

1. "Settings"

2. "Profiles"

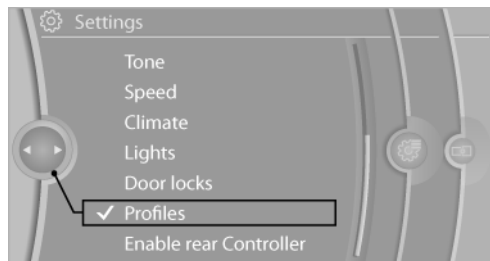

3. Select a profile.

The profile called up is assigned to the remote control currently used.

Renaming profiles

1. "Settings"

2. "Profiles"

The current profile is selected.

3. Call up "Options".

4. "Rename current profile"

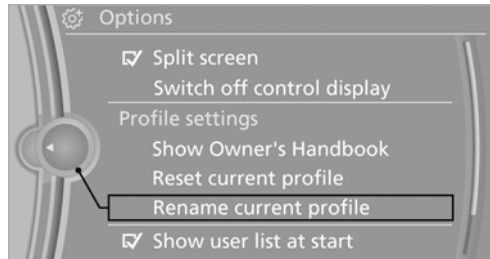

Resetting profiles

Settings of the active profile are reset to factory settings.

1. Switch on ignition.

2. "Settings"

3. "Profiles"

The current profile is selected.

4. Call up "Options".

5. "Reset current profile"

Importing profiles

Existing settings and contacts are overwritten with the imported profile.

1. "Settings"

2. "Profiles"

3. "Import profile"

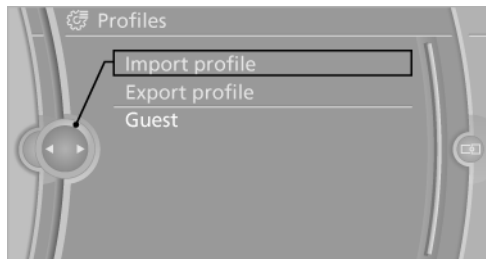

4. BMW Online: "BMW Online"

USB interface: "USB device"

Exporting profiles

Most settings of the active profile and the saved contacts can be exported.

This can be beneficial for safeguarding and recalling personal settings, for example if items are accidentally moved or deleted.

1. "Settings"

2. "Profiles"

3. "Export profile"

4. BMW Online: "BMW Online":

USB interface: "USB device"

Using a guest profile

With the guest profile, individual settings can be made without affecting the three personal profiles.

This can be beneficial if a driver without their own profile uses the vehicle temporarily.

1. "Settings"

2. "Profiles"

3. The current profile is selected.

4. Call up "Guest".
5. Make the settings.

Note: the guest profile cannot be renamed.

Show profile list at start

The profile list can be shown at the start to select the desired profile.

1. "Settings"
2. "Profiles"
3. Call up "Options".
4. "Show user list at start"

Personal Profile settings

The following functions and settings can be saved in a profile.

More details regarding the settings at:

- ▷ Collision warning: warning time, last state on/off
- ▷ Exterior mirror position.
- ▷ CD/multimedia: last audio source listened to.
- ▷ Drive experience switch: sport program
- ▷ Seat position: called up automatically when unlocking.
- ▷ Favourites buttons: assignment.
- ▷ Head-Up Display: display selection, brightness, position and rotation.
- ▷ Headlight courtesy delay feature: time setting.
- ▷ Sound: sound settings.
- ▷ Automatic air conditioning/Automatic air conditioning with extended functionality: settings.
- ▷ Navigation: map views, route criteria, voice instructions on/off.
- ▷ Park Distance Control, PDC: set volume of the sound signal.
- ▷ Radio: saved stations, last station listened to, special settings.

- ▷ Rear-view camera: selection of the functions and type of display
- ▷ Language of the control display
- ▷ Lane departure warning: last state, on/off
- ▷ Triple turn signal.
- ▷ TV: saved channels, selected channel, special settings
- ▷ Locking of the vehicle: after a short time or after driving off.

Central locking system

Principle

The central locking is activated when the driver's door is closed.

The following are unlocked or locked simultaneously:

- ▷ Doors
- ▷ Tailgate
- ▷ Fuel filler flap

Operating from outside

- ▷ Via the remote control
- ▷ Via the driver's door lock.
- ▷ Via the door handles on the driver's or front passenger's door.
- ▷ Via the button in the tailgate

At the same time as locking and unlocking via the remote control:

- ▷ Depending on equipment, the anti-theft alarm system is also switched on/off. The anti-theft system prevents the doors from being able to be unlocked using the securing buttons or the door opener.
- ▷ The welcome lights, interior lights and courtesy lighting are switched on or off.
- ▷ The alarm system, see page 39, is armed or disarmed.

Operating from inside

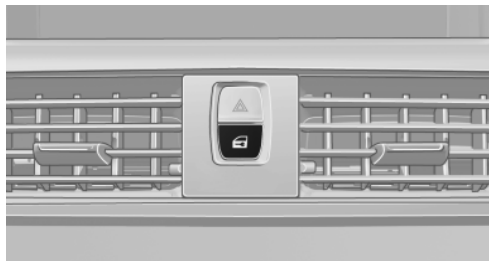

Via the button for the central locking system

If the vehicle has been locked from inside, the fuel filler flap remains unlocked.

In the event of an accident of the corresponding severity, the central locking is released automatically.

The hazard warning system and interior lights illuminate.

Opening and closing: from outside

With the remote control

General



Removing the remote control

Persons remaining in the car or pets left inside can lock the doors from the inside. You should therefore take the remote control with you when you get out of the vehicle so that the car can be opened from the outside. ◀

Unlocking



Press the button on the remote control.

The vehicle is unlocked.

Welcome light, interior light and courtesy light are switched on.

You can set how the car is unlocked.

The setting is saved for the remote control currently in use.

1. "Settings"
2. "Door locks"
3. "Unlock button:"

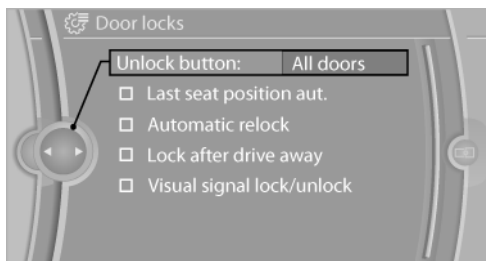

4. Select the desired function:
 - ▷ "Driver's door only"

Only the driver's door and fuel filler flap are unlocked. Pressing again unlocks the entire vehicle.
 - ▷ "All doors"

The entire vehicle is unlocked.

Comfort opening

The windows and glass roof can also be opened simultaneously via the remote control.



Keep the button on the remote control pressed.

The windows and the glass roof are opened. Releasing the button stops the movement.

Locking



Press the button on the remote control.



Locking from the outside

Do not lock the vehicle from the outside when there is someone inside it, as it cannot then be unlocked from the inside in some national-market versions. ◀

Comfort closing

The remote control can be used to simultaneously close the windows and the glass roof, as well as to fold in the exterior mirrors.



Keep the button on the remote control pressed.

The windows and the glass roof are closed and the exterior mirrors are folded in.



Observe the closing operation

Follow closing operation and ensure that nobody gets jammed. ◀

Releasing the button stops the movement.

Switch on interior light and courtesy lighting



With the car locked, press the button on the remote control.

Opening the tailgate



Press the button on the remote control for approximately one second.

The tailgate opens, regardless of whether it was locked or unlocked.

The tailgate swings rearwards and upwards when opened.

Make sure that there is sufficient clearance.

On models fitted with certain items of equipment, the tailgate can be opened with the remote control only if the car has first been unlocked.

To prevent being locked out, do not place the remote control in the boot. The tailgate is locked again as soon as it is pressed shut.



Protect edges.

Sharp objects or those with sharp edges may knock against the rear window while the vehicle is in motion and damage the heating conductor of the rear window. Protect edges. ◀

Acknowledgement signal of the vehicle

1. "Settings"
2. "Door locks"
3. "Visual signal lock/unlock"

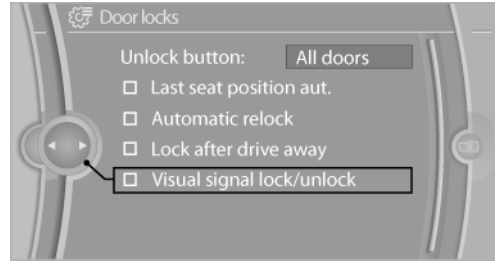

Calling up seat, mirror setting

The last adjusted driver's seat and exterior mirror position is stored for the currently used remote control.

When the vehicle is unlocked, this position is called up automatically if the function has been enabled.



Risk of jamming when the seat moves back

If this function is used, first ensure that the footwell behind the driver's seat is clear. Otherwise, with any moving back of the seat people could be injured or objects be damaged. ◀

Adjustment procedure is interrupted:

- ▶ By operating the switch or the seat adjustment.
- ▶ By touching a button of the seat and mirror memory.

Enable setting

1. "Settings"
2. "Door locks"

3. "Last seat position aut."

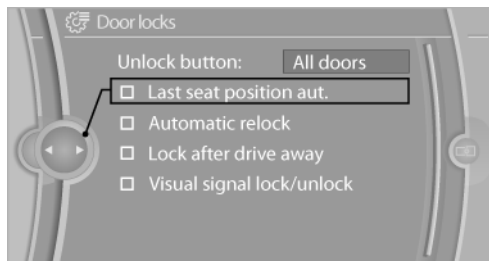

Malfunction

If it is no longer possible to lock or unlock the vehicle with the remote control the battery might be flat or the problem might be due to interference from external sources such as mobile phones, metallic objects, high-tension electric cables, radio transmitters, etc.

In this case, lock or unlock the vehicle with the integrated key via the door lock.

Via the door lock

General

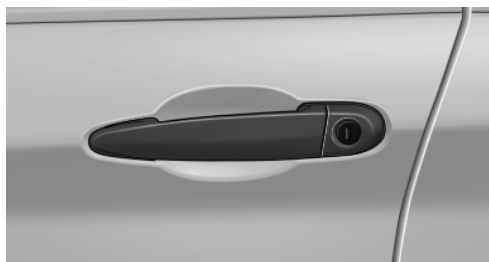

Locking from the outside

Do not lock the vehicle from the outside when there is someone inside it, as it cannot then be unlocked from the inside in some national-market versions. ◀

Removing the key before pulling the door handle

To avoid damage to the paint and key, always remove the key before pulling the outer door handle. ◀

With certain national-market versions, the alarm is triggered when opening via the door lock.

To end this alarm, unlock the vehicle with the remote control or turn on the ignition, with special ID of the remote control as necessary.

Depending on the equipment fitted in the vehicle, it may be the case that only the driver's door is locked or unlocked using the door lock.

Locking the doors and tailgate together

To lock all doors and the tailgate together:

1. With the doors closed, lock the car using the central locking button inside the vehicle.
2. Unlock and open the driver's or front passenger's door.
3. Lock vehicle.
 - ▷ Lock the driver's door using the integrated key in the door lock or
 - ▷ Press the locking button on the front passenger's door and close the door from the outside.

It is only possible to lock the fuel filler flap with the remote control.

Manual operation

In the event of an electrical defect, lock or unlock the driver's door with the integrated key using the door lock.

Opening and closing: from inside

Locking and unlocking

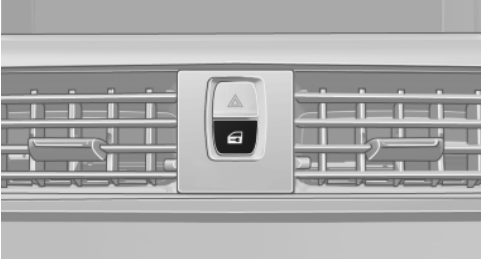

By pressing the button, the doors and the tailgate are locked or unlocked, but not deadlocked, when the front doors are closed.

The fuel filler flap remains unlocked.

Unlocking and opening

- ▶ Either unlock the doors together using the central locking button and then pull the door handle above the armrest or
- ▶ Pull twice on the door handle on each door: the first pull unlocks the door, the second pull opens the door.

Automatic locking

The setting is saved for the remote control currently in use.

1. "Settings"
2. "Door locks"
3. Select the desired function:
 - ▶ "Automatic relock"

The vehicle is locked automatically after a short while if no door is opened.
 - ▶ "Lock after drive away"

On driving off, the vehicle is locked automatically.

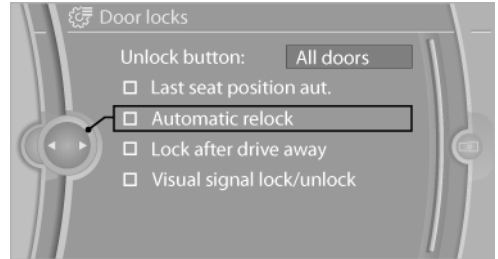

Tailgate

Opening

The tailgate swings rearwards and upwards when opened. Make sure that there is sufficient clearance.



Protect edges.

Sharp objects or those with sharp edges may knock against the rear window while the vehicle is in motion and damage the heating conductor of the rear window. Protect edges. ◀

Opening from outside



- ▶ Press the button on the tailgate.
- ▶  Press the button on the remote control for approximately one second.

On certain national-market versions, the tailgate can only be opened with the remote control if the car has first been unlocked.

Opening from inside



Press the button in the driver's footwell.

When the vehicle is stationary, the tailgate is opened unless it has been double-locked.

Closing



The recessed handles in the tailgate lining make it easier to pull the tailgate down.



Risk of trapping

To avoid injuries, ensure that the closing area of the tailgate is unobstructed. ◀



Do not lay the remote control in the boot

Keep the remote control with you at all times and do not lay it in the boot, as otherwise there is a risk of the remote control being locked inside the vehicle when the tailgate is closed. ◀

Locking the vehicle



Press the button on the inside of the tailgate. With the driver's door closed, the vehicle is completely locked.

Automatic operation of the tailgate

Adjusting the opening height

The extent to which the tailgate opens can be set.



Adjusting the opening height



When setting the opening height, make sure that there is a space of at least 10 cm, 4 in above the tailgate. Otherwise, for example, if the load status has changed, the ceiling height might not be sufficient for the opened tailgate. ◀

1. "Settings"
2. "Tailgate"
3. Turn the controller until the desired opening height is reached.

Opening

The tailgate opens completely.



- ▷ Press the button on the outside of the tailgate.
- ▷  Press the button on the remote control for approximately one second.
- ▷  Press the button in the driver's footwell.

Pressing the button again stops the movement.

The opening procedure is also interrupted:

- ▷ When starting the engine.
- ▷ If the vehicle begins to move.
- ▷ Press the button in the driver's footwell.
- ▷ By pressing the button on the inside of the tailgate.

Closing



- ▶ Press the button on the inside of the tailgate. The tailgate closes automatically. Pressing the switch again stops the movement.



With Comfort Access:

- ▶ Press the button, arrow 1, on the inside of the tailgate. The tailgate closes automatically. Pressing the switch again stops the movement.
- ▶ Press the button, arrow 2. The tailgate closes automatically and the vehicle is locked.



- ▶ Press the button on the outside of the tailgate. Pressing the switch again stops the movement.
- ▶  Keep the button on the remote control pressed. Releasing the button stops the movement.

The shutdown process is interrupted:

- ▶ When starting the engine.
- ▶ When driving off suddenly.



Risk of trapping

To avoid injuries, ensure that the closing area of the tailgate is unobstructed. ◀



Do not lay the remote control in the boot

Keep the remote control with you at all times and do not lay it in the boot, as otherwise there is a risk of the remote control being locked inside the vehicle when the tailgate is closed. ◀

Manual operation

In the case of an electrical defect, operate the unlocked tailgate manually, proceeding slowly and avoiding sudden movements.

Comfort Access

Principle

Access to the vehicle is possible without activating the remote control.

It is sufficient to have the remote control on your person, for example in a jacket pocket.

The vehicle automatically recognises the remote control when it is in the immediate vicinity or inside the car.

Comfort Access supports the following functions:

- ▷ Unlocking/locking the vehicle.
- ▷ Comfort closing.
- ▷ Unlocking the tailgate separately.
- ▷ Start the engine.

Operating requirements

- ▷ No external sources of interference in the vicinity.
- ▷ To lock, the remote control must be located outside the vehicle.
- ▷ Approximately two seconds need to elapse before the car can be unlocked and locked again.
- ▷ An engine start is only possible if the remote control is in the vehicle.

Comparison with conventional remote control

The above functions can be operated by pressing the buttons of the remote control or using Comfort Access.

Unlocking

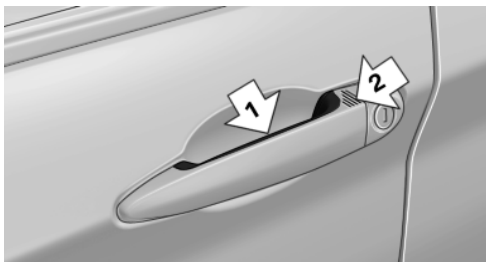

Firmly grab the handle on the driver's door and front passenger's door, arrow 1. This corresponds to pressing the  button on the remote control.

Locking

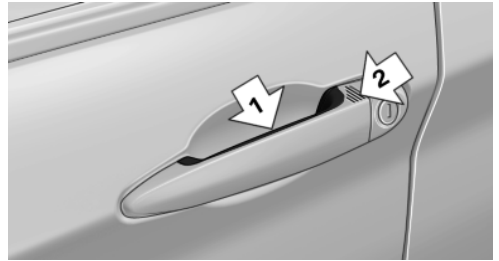

Use your finger to touch the door handle, arrow 2, for approximately one second.

This corresponds to pressing the  button on the remote control.

To reduce the burden on the vehicle battery, make sure that the ignition and all electrical consumers are switched off prior to locking.

Comfort closing

Keep your finger pressed on the area of the door handle, arrow 2.

In addition to locking, the windows and the glass sunroof are closed.



Observe the closing operation

Follow closing operation and ensure that nobody gets jammed. ◀

Release tailgate individually

Press the button on the outside of the tailgate.

This corresponds to pressing the  button on the remote control.



Do not lay the remote control in the boot

Keep the remote control with you at all times and do not lay it in the boot, as otherwise there is a risk of the remote control being locked inside the vehicle when the tailgate is closed. ◀

Malfunction

External sources of interference in the vicinity can cause the Comfort Access system to malfunction: sources of this nature include mobile

phones, metallic objects, high-tension overhead cables, radio transmitters, etc.

In this situation, open or close the vehicle using the buttons on the remote control or via the door lock with the integrated key.

Alarm system

Principle

The alarm system is triggered if:

- ▷ A door, the bonnet or the tailgate is opened.
- ▷ Movements inside the vehicle.
- ▷ The car's incline changes, for instance if an attempt is made to jack it up and steal the wheels or to raise it prior to towing away.
- ▷ There is an interruption in the power supply from the battery.

The alarm system will respond briefly to unauthorised attempts to access the car as follows:

- ▷ Acoustic alarm.
- ▷ Switching on the hazard warning flashers.

Arming and disarming

General

At the same time as locking and unlocking the vehicle using the remote control, Comfort Access or using the door lock the alarm system is also armed or disarmed.

Door lock with alarm system armed

Opening certain national-market versions via the door lock triggers the alarm.

To end this alarm, unlock the vehicle with the remote control or turn on the ignition, with special ID of the remote control as necessary.

Tailgate with alarm system armed

The tailgate can also be opened using the remote control when the alarm system is armed.



Press the button on the remote control for approximately one second.

On closing the tailgate, it is locked again and monitored. The hazard warning system flashes once.

On models fitted with certain items of equipment, the tailgate can be opened with the remote control only if the car has first been unlocked.

Switching off the alarm

- ▷ Unlock the car with the remote control.
- ▷ ForComfort Access: Pull on door handle when carrying remote control.

Indicator light on the interior mirror

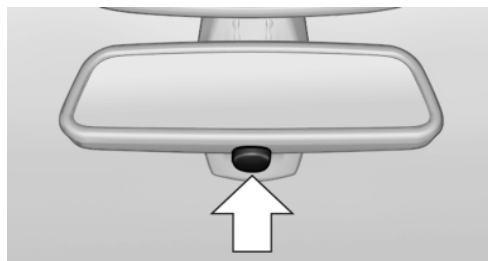

- ▷ Indicator light flashes every 2 seconds: System is armed.
- ▷ Indicator light flashes after locking: Doors, bonnet, or tailgate are not properly closed; the rest is secured. After ten seconds, the indicator light flashes continuously. Interior protection and tilt alarm sensor are not active.
- ▷ The indicator light no longer illuminates after the car has been unlocked: No attempt has been made to tamper with the vehicle.
- ▷ The indicator light flashes after unlocking until the engine is started, but for no longer than approximately five minutes: The alarm has been triggered.

Tilt alarm sensor

The incline of the vehicle is monitored.

Alarm system responds, for example, when there is an attempt to steal a wheel or when towing away.

Interior movement detector

To ensure perfect functioning, the windows and glass sunroof must be closed.

Avoiding false alarms

The tilt alarm sensor and interior movement detector can be switched off together, for example in the following situations:

- ▷ In car washes.
- ▷ In two-level garages.
- ▷ During transport via motorail, car ferry or trailer.
- ▷ When there are animals in the vehicle.

Switching off the tilt alarm sensor and interior movement detector

 Press the button on the remote control again within 10 seconds, as soon as the vehicle is unlocked.

The indicator light illuminates for approximately 2 seconds and then flashes again.

The tilt alarm sensor and the interior movement detector are switched off until the next time the car is locked.

Power windows

General

 Removing the remote control

Take the remote control with you when you leave the car, otherwise children, for example, could operate the power windows and possibly injure themselves. ◀



Opening

▷  Push the switch as far as the resistance point.

The window opens as long as the switch is held.

▷  Push the switch past the resistance point.

The window opens automatically.

Pressing the switch again stops the movement.

Comfort opening, see page 32, via the remote control.

Closing

 Risk of trapping

To avoid injuries, ensure that the closing area of the window is unobstructed during closing. ◀

▷  Pull the switch as far as the resistance point.

The window closes as long as the switch is held.

▷  Pull the switch past the resistance point.

The window closes automatically.

The movement is stopped by pressing the switch.

Comfort operation, see page 32, via the remote control.

Comfort closing, see page 38, with Comfort Access.

After switching off the ignition

Windows can still be operated:

- ▷ For some time with radio readiness switched on.
- ▷ For approximately one minute with the ignition switched off.

Anti-trap mechanism

If the closing power exceeds a certain value on closing a window, the closing operation is interrupted.

The window opens again slightly.

 Danger of trapping despite anti-trap mechanism

Despite the anti-trap mechanism, make sure that the windows are not obstructed as they close; if this precaution is not taken, the risk remains that thin objects, for instance, could fail to interrupt the closing movement. ◀

 No accessories on windows
Do not attach any accessories in the movement range of the windows, as otherwise the anti-trap mechanism will be impaired. ◀

Closing without the anti-trap mechanism

 Risk of trapping
To avoid injuries, ensure that the closing area of the window is unobstructed during closing. ◀

If an external hazard or ice on the windows does not allow you to close the windows normally, proceed as follows:

1. Pull the switch past the resistance point and hold it there.
The anti-trap mechanism is restricted and the window opens slightly when the closing force exceeds a certain value.

2. Pull the switch past the resistance point again within approximately four seconds and hold it there.

The window closes without the anti-trap mechanism.

Safety switch

The safety switch can be used to prevent children from opening and closing the rear windows by means of the switches in the rear, for example.

Switching on and off



Press the button.

When the safety function is switched on, the LED is illuminated.



Safety switch for rear operation

Press the safety switch when carrying children in the rear seats, otherwise careless closing of the windows could result in injury. ◀

Roller sunblinds

Roller sunblinds for rear side windows

Pull the roller sunblind out with the loop and hang into the holder.



Do not open the window if the roller sunblind has been pulled up

Do not open the window when the roller sunblind has been retracted, otherwise there is a risk of damage and subsequently injury at high speeds. ◀

Panorama glass roof

General

The glass roof and the sliding panel can be operated separately or together with the same switch.

**Risk of trapping**

To avoid injuries, ensure that the closing area of the glass roof is unobstructed during closing. ◀

**Removing the remote control**

Take the remote control with you when you leave the car, otherwise children could operate the roof and possibly injure themselves. ◀

**Raising the glass roof**

Press the top of the switch.

- ▶ From the closed position, the roof is raised and the sliding panel opens slightly.
- ▶ The opened roof closes to the raised position. The sliding panel remains completely open.

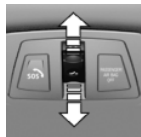
Opening/closing the sliding panel

- ▶ Push and hold the switch in the desired direction as far as the resistance point. The sliding panel moves as long as the switch is held.
- ▶ Push the switch beyond the resistance point in the desired direction. The sliding panel moves automatically. The movement is stopped by pressing the switch again.

Opening/closing glass roof

Proceed as described under sliding trim when the sliding trim is open.

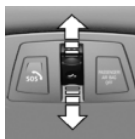
Opening and closing the glass roof and sliding panel together

Push the switch twice in rapid succession beyond the resistance point in the desired direction.

The glass roof and the sliding panel open together. The movement is stopped by pressing the switch again.

Comfort operation, see page 32, via the remote control.

Comfort closing, see page 38, with Comfort Access.

Comfort position

The roof is not entirely open in the comfort position. This reduces wind noise in the passenger compartment.

The glass roof stops in the comfort position when it opens and closes completely. You can continue the movement by subsequently pressing the button.

After switching off the ignition

The roof can still be opened or closed for approximately 1 minute after the ignition has been switched off.

Anti-trap mechanism

If the closing power of the glass roof exceeds a certain value, the closing operation is interrupted from approximately the half-open position, or during closing from the raised position.

The roof opens again slightly.



Danger of trapping despite anti-trap mechanism

Despite the anti-trap mechanism, make sure that the roof is not obstructed as it closes; if this

precaution is not taken, the risk remains that thin objects, for instance, could fail to interrupt the closing movement. ◀

Closing without the anti-trap mechanism

In the event of danger from outside, for example, proceed as follows:

1. Slide the switch forwards beyond the resistance point and hold it there.

The anti-trap mechanism is restricted and the roof opens slightly when the closing force exceeds a certain value.

2. Press the switch forwards once again beyond the resistance point and hold until the roof closes without the anti-trap mechanism.

Initialising after power failure

It is possible that the roof functions are restricted after a power cut during the opening or closing process.

Initialising the system

The system can be initialised when the vehicle is stationary and the engine is running.

With the initialisation the roof closes without the anti-trap mechanism.



Risk of trapping

To avoid injuries, ensure that the closing area of the glass roof is unobstructed during closing. ◀



Press the top of the switch and hold until the initialisation is complete:

- ▶ Initialisation begins within 15 seconds and is complete when the roof and sliding panel are fully closed.
- ▶ The roof closes without the anti-trap mechanism.

Adjusting

Vehicle Equipment

This chapter describes all standard, national and special equipment provided in the model series. Therefore equipment not available in a vehicle is also described, for example the selected special equipment or national version. That also applies to safety-relevant functions and systems.

Safe seated position

A seated position that suitably reflects your requirements is a vital condition of relaxed driving with a minimum of fatigue.

In the event of an accident, the seated position plays an important role together with:

- ▷ Seat belts, see page 47.
- ▷ Head restraints, see page 49.
- ▷ Airbags, see page 92.

Seats

General

 No seat adjustment while the vehicle is in motion

Do not adjust the seat when driving, otherwise the seat could move unexpectedly, making the driver lose control of the vehicle, leading to an accident. ◀

 Do not incline the backrest too far towards the rear

Also, do not incline the backrest of the front passenger seat too far back when driving, otherwise there is a risk of sliding underneath the seat belt in case of accident. The protective effect of the seat belt is lost. ◀

Manually adjustable seats

Overview

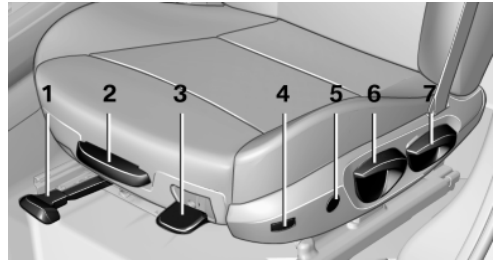

- 1 Forward/back
- 2 Thigh support
- 3 Seat angle
- 4 Backrest width
- 5 Lumbar support
- 6 Height
- 7 Backrest angle

Forward/back

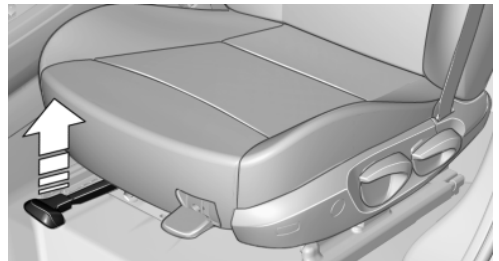

Pull the lever and slide the seat in the desired direction.

After releasing the lever, move the seat gently forward or back to make sure it engages properly.

Height

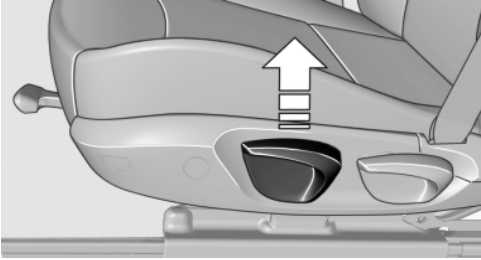

Pull the lever and add or remove pressure on the seat as required.

Backrest angle



Pull the lever and add or remove pressure on the backrest as required.

Seat angle

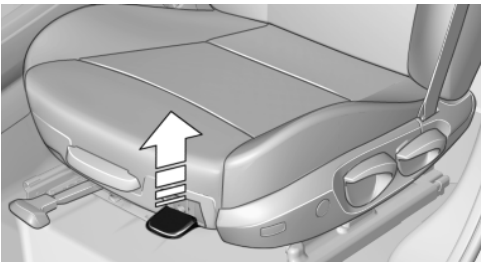

Pull the lever and move the seat until the desired angle is reached. After releasing the lever, sit on and get up out of the seat to make sure it engages properly.

Electrically adjustable seats

Overview

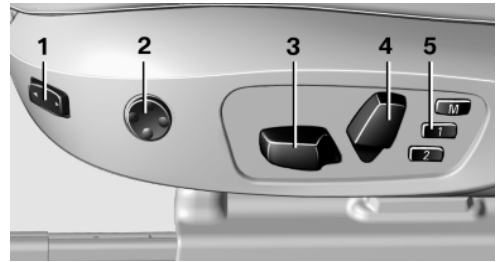

- 1 Backrest width
- 2 Lumbar support
- 3 Forward/back, height, seat angle
- 4 Backrest angle
- 5 Seat and mirror memory for driver's seat

Note

The driver's seat setting is saved for the remote control currently in use. When the vehicle is unlocked using the remote control, this position is called up automatically if the function, see page 33, for this has been activated.

Settings in detail

1. Longitudinal direction.

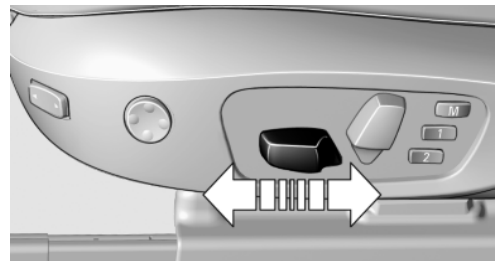

2. Height.

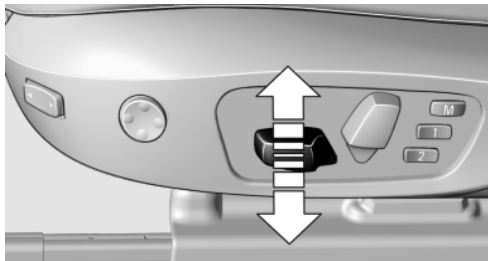

3. Seat angle.

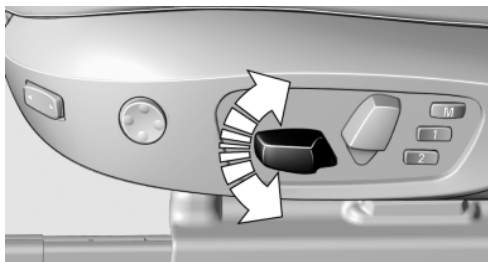

4. Backrest angle.

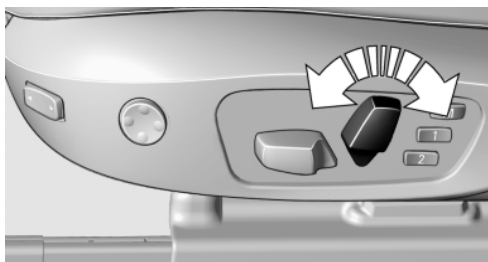

Thigh support

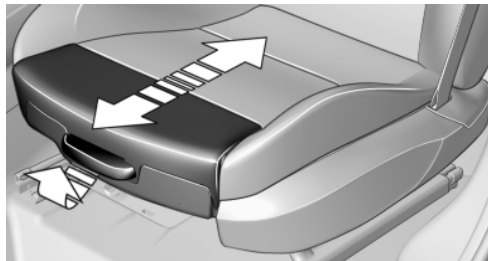

Pull the lever on the front of the seat and adjust the thigh support.

Lumbar support

The curvature of the backrest can be altered to support the lordosis, the lumbar section of the spine. The upper edge of the pelvis and the spinal column are supported to encourage an upright posture.



- ▶ Press the switch at the front/rear.
The curvature is increased/decreased.
- ▶ Press the switch at the top/bottom.
The curvature is shifted upwards/downwards.

Backrest width



Alter the width of the backrest via the side cushions to adjust the lateral support.

Seat heating, front



Switch on



Press the button once per temperature stage.

Maximum temperature is indicated by three LEDs.

If the journey is continued within about 15 minutes, the seat heating automatically activates with the last temperature set.

Switch off



Press and hold down the button. LEDs go out.

Seat heating, rear



Switch on



Press the button once per temperature stage.

Maximum temperature is indicated by three LEDs.

If the journey is continued within about 15 minutes, the seat heating automatically activates with the last temperature set.

Switch off



Press and hold down the button. LEDs go out.

Seat belts

Number of seat belts

Your vehicle has been fitted with five seat belts for the safety of you and your passengers. However, they can only offer protection when adjusted correctly.

Notes

Before driving off, always make sure that all occupants have fastened their seat belts.

The airbags are a complementary safety feature and not a substitute for the seat belts.

- ▷ The upper belt anchorage is suitable for adults of any stature as long as the seat is correctly adjusted.
- ▷ Both belt anchorages incorporated into the rear bench seat are determined for those sitting on the left and right.
- ▷ The inner seat belt buckle of the rear seat bench is intended exclusively for the vehicle occupant in the middle.



One person per seat belt

Never restrain more than one person with each seat belt. Babies or small children must not travel on the lap of another occupant. ◀



Fastening the seat belt

Place the seat belt tightly over the pelvis and shoulder as close as possible to the body and make sure that it is positioned low at the hip in the area of the pelvis and is not pressing on your midriff. Otherwise, the seat belt can slip

over the hip and injure the midriff in the event of a head-on collision.

The seat belt must not pass across the neck. It should not be pulled across sharp edges or routed or fastened over hard or fragile objects. ◀



Impairment of the restraining effect

Avoid wearing bulky clothing and regularly pull the seat belt in the upper-body area taut, otherwise its restraining effect could be impaired. ◀



Warning

Seat belts are designed to bear upon the bony structure of the body and should be worn low across the front of the pelvis, or the pelvis, chest and shoulders, as applicable. Wearing the lap section of the belt across the abdominal area must be avoided.

Seat belts should be adjusted as firmly as possible, consistent with comfort, to provide the protection for which they have been designed. A slack belt will greatly reduce the protection afforded to the wearer.

Care should be taken to avoid contamination of the webbing by polishes, oils and chemicals and particularly battery acid. Cleaning may safely be carried out using mild soap and water. The belt should be replaced if webbing becomes frayed, contaminated or damaged. Seat belts should not be worn with straps twisted. Each seat belt assembly must only be used by one occupant; it is forbidden to put a belt around a child being carried on the occupant's lap.

It is essential to replace the entire assembly after it has been worn in a severe impact even if damage to the assembly is not obvious. ◀



Warning

No modifications or additions should be made by the user which will either prevent the seat belt adjusting devices from operating to remove slack, or prevent the seat belt assembly from being adjusted to remove slack. ◀

Adjustment for automatic retracting seat belts

- ▷ Draw the buckle tongue attached to the seat belt across the body and press it into the buckle catch until a 'click' is heard.
- ▷ Adjustment of the belt length is very important. To adjust the lap belt and check whether the buckle has locked correctly, pull upwards on the shoulder strap until the lap belt fits tightly.
- ▷ The length of the diagonal shoulder strap adjusts itself automatically to allow freedom of movement.
- ▷ To release the seat belt, press the button on the buckle catch unit.

Fastening the seat belt

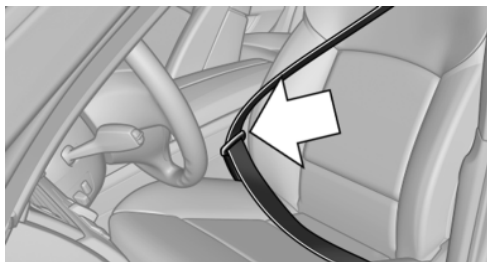

The seat belt buckle must be heard to engage.

Unfastening the seat belt

1. Hold onto the belt.
2. Press the red button on the belt buckle.
3. Guide the belt back up to the reel.

Seat belt reminder for driver's and front passenger's seat



A Check Control message is displayed. Check whether the seat belt has been fastened correctly.

The seat belt reminder is activated when the seat belt on the driver's side is not fastened. On some national versions, the seat belt reminder is also activated above approximately 8 km/h, 5 mph if the front passenger's seat belt is not

fastened or if heavy objects are located on the seat.

Damaged seat belts

In the event of stress due to an accident or damage:

Replace the belt system, including the seat-belt tensioner, and have the belt anchorage checked.

 Checking and replacing the seat belts

Only have this work carried out at the Service Centre, as otherwise correct functioning of this safety device is not ensured. ◀

Front head restraints

Correctly adjusted head restraint

Head restraints adjusted to the correct height reduce the risk of injuries to the neck in the event of an accident.

 Adjusting head restraint

Adjust the head restraint correctly for all occupied seats, as otherwise there is an increased risk of injury in the event of an accident. ◀

Height

Adjust the head restraint so that its centre is approximately at the height of your ear.

Spacing

Adjust the spacing so that the head restraint is as close as possible to the back of the head.

If necessary, adjust the spacing using the incline of the seat backrest.

Active head restraint

In the event of a severe rear-end collision, the active head restraint automatically reduces the gap to the head.

 Reduced protection

- ▷ Do not fit any covers on the seats or head restraints.
- ▷ Do not hang objects such as coat hangers on the head restraints.
- ▷ Attach only BMW approved accessories to the seat or head restraint.

Otherwise, the protective function of the active head restraint is impaired and personal safety is endangered. ◀

Adjust height

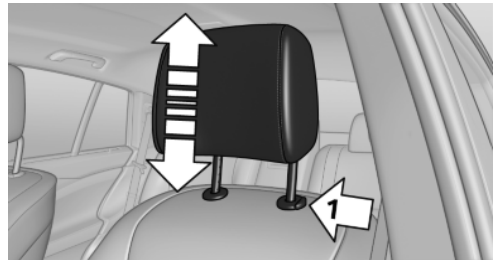

- ▷ Up: pull
- ▷ Down: press the button, arrow 1, and slide the head restraint downwards.

Removing

The head restraints cannot be removed.

Rear head restraints

Correctly adjusted head restraint

Head restraints adjusted to the correct height reduce the risk of injuries to the neck in the event of an accident.

 Adjusting head restraint

Adjust the head restraint correctly for all occupied seats, as otherwise there is an increased risk of injury in the event of an accident. ◀

Height

Adjust the head restraint so that its centre is approximately at the height of your ear.

Adjust height

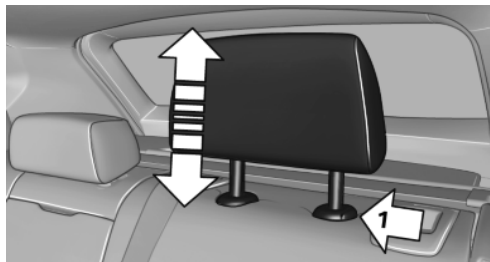

- ▷ Up: pull
- ▷ Down: press the button, arrow 1, and slide the head restraint downwards.

The height of the centre head restraints cannot be adjusted.

Removing

Only remove the head restraint if no-one will be sitting on the seat in question.

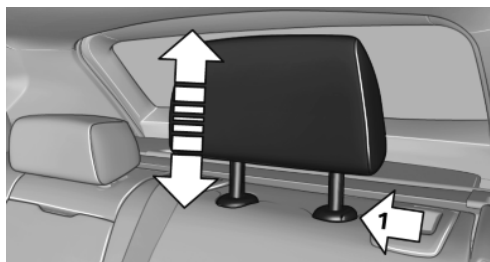

1. Pull up the head restraint until it stops.
2. Press the button, arrow 1, and pull the head restraint fully out.



Before carrying passengers

Install the head restraints again before carrying passengers, otherwise the head restraints do not offer protection. ◀

Seat and mirror memory

General



You can save and recall two different positions for the driver's seat and exterior mirrors for each remote control. Settings for backrest width and lumbar support are not saved.

Saving

1. Switch on ignition.
2. Set desired position.
3.  Press the button. LED in button is illuminated.
4. Press the desired button 1 or 2. LED turns off.

If the M button was pressed accidentally:



Press the button again.

LED turns off.

Recalling



Do not call up the memory while the vehicle is in motion

Do not call up the memory while the vehicle is in motion, otherwise an unexpected seat or steering wheel movement may cause an accident. ◀

Convenience function

1. Open the driver's door.
2. Switch the ignition off.
3. Briefly press button 1 or 2 as desired.

The relevant seat adjustment is done automatically.

The process is cancelled if a seat adjustment switch or one of the buttons is pressed.

Safety function

1. Close the driver's door or switch the ignition on.
2. Keep button 1 or 2 pressed as desired until the adjustment procedure has been concluded.

Calling up has been disabled

After a short time, calling up saved seat positions is disabled to prevent the battery from being discharged.

To reactivate calling up:

- ▶ Open or close a door or the tailgate.
- ▶ Press a button on the remote control.
- ▶ Press the start/stop button.

Mirrors

Exterior mirrors

Overview



- 1 Adjusting
- 2 Left/right, automatic parking function
- 3 Folding in and out

General



Correctly estimating distance

Objects reflected in the mirrors are closer than they appear. Do not gauge your distance from following traffic based on what you see in the mirror; otherwise there is an increased risk of an accident. ◀

Depending on the equipment, the mirror setting is saved for the remote control currently in use. When the vehicle is unlocked using the remote control, this position is called up automatically if the setting for this has been enabled.

Selecting a mirror



Switching to other mirror:

Push mirror changeover switch.

Electrical adjustment



Corresponding to movement of button

Saving positions

Seat and mirror position memory, see page 50.

Adjusting manually

In the event of an electrical defect, for example, press the borders of the mirror glass.

Automatic parking function

When reverse gear is engaged, the glass of the mirror on the front passenger side tilts slightly down. This improves the view of the kerb or other obstacles near the ground, for example when parking.

Activating

1.  Push mirror changeover switch into position for driver's mirror.
2. Engage transmission position R.

When towing a trailer, the automatic parking function is switched off.

Deactivating

Push mirror changeover switch into position for front passenger's mirror.

Folding in and out

 Press the button.

Possible up to approximately 20 km/h, 15 mph.

An advantage, for example

- ▷ In car washes.
- ▷ In narrow streets.
- ▷ When folding mirrors back out that have been folded in manually.

Folded-in mirrors automatically fold out at approximately 40 km/h, 25 mph.

 Folding mirrors in a car wash

Before driving through a car wash, fold the mirrors in manually or by pressing button; otherwise, they could be damaged due to the width of the car. ◀

Automatic heating

Both exterior mirrors are automatically heated with the engine running.

Automatically dimming

Both exterior mirrors are automatically dimmed. Photocells in the interior mirror, see page 52, are used for control.

Interior mirror

Reducing glare

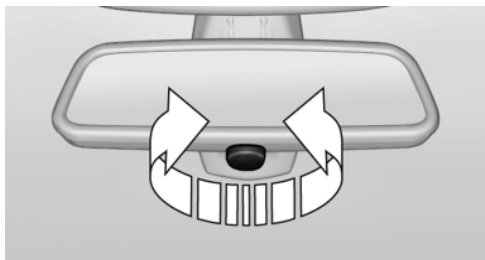

From behind when driving at night: turn button.

Interior mirror, automatic-dim

Principle

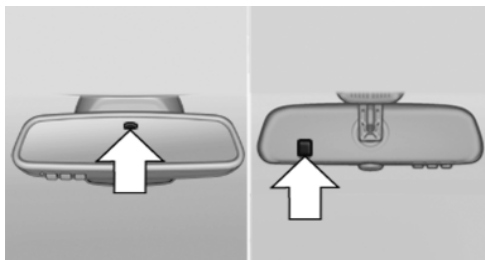

The function is controlled by photocells:

- ▷ In the mirror glass
- ▷ On the back of the mirror

Operating requirements

To keep the system functioning properly:

- ▷ Keep photocells clean.
- ▷ Do not obstruct the zone between the interior mirror and windscreen.

Steering wheel

General

 Do not adjust the steering wheel whilst the vehicle is in motion

Do not adjust the steering wheel position while the vehicle is in motion, or an accident may result from any unexpected movement. ◀

Electric steering wheel lock

With manual transmission: The steering wheel locks automatically when the driver's door is opened.

Switch on ignition to unlock.

 Switch on ignition
Before moving the vehicle, switch on the ignition, otherwise the electric steering wheel lock is not locked and the vehicle cannot be steered. ◀

Adjusting

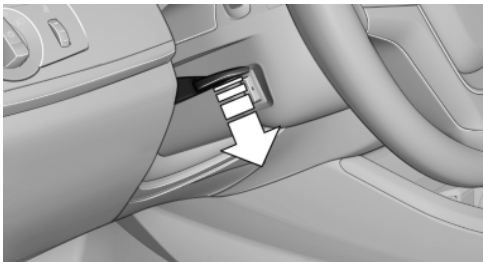

1. Fold the lever downwards.
2. Move the steering wheel to the preferred height and angle to suit your seated position.
3. Swing the lever back up.

Steering wheel heating



Switching on/off



Press the button.

- ▷ On: LED is illuminated.
- ▷ Off: LED turns off.

Carrying children in safety

Vehicle Equipment

This chapter describes all standard, national and special equipment provided in the model series. Therefore equipment not available in a vehicle is also described, for example the selected special equipment or national version. That also applies to safety-relevant functions and systems.

Important considerations

Note

 Children in the vehicle

Do not leave children unattended in the vehicle, as they could otherwise endanger themselves and/or other persons by opening the doors, for example. ◀

Not for Australia/New Zealand: Suitable seats

Generally, the front passenger seat and the outer rear seats are suitable for the installation of universal child restraints for all ages that have been approved for the age group in question.

Always carry children at the rear

Accident research has shown that the safest place for children is on the rear seat.

 Carry children at the rear

Children under the age of 12 or smaller than 150 cm, 5 ft should always travel in the rear in appropriate child restraints, otherwise there is a greater risk of injury in the event of an accident. ◀

Not for Australia/New Zealand: Children on the front passenger's seat

If it becomes necessary to use a child restraint in the front passenger's seat, make sure that the

front and side airbags on the passenger's side are disabled. Front passenger airbags can only be deactivated with the key switch for front passenger airbags, see page 94.

 Deactivating the front passenger airbags
If you fit a child restraint system in the front passenger's seat, the front passenger airbags must be deactivated, otherwise a child travelling on that seat will face an increased risk of injury if the airbags are deployed, even if a child restraint system is used. ◀

Fitting child restraints

Child restraint systems

Suitable child restraint systems are available from your Service Centre for every class of age or weight.

Before installation

Make sure backrests are engaged before fitting child restraints.

Notes

 Manufacturer specifications for child restraints

When selecting, installing and using child restraint systems, follow the manufacturer's information, otherwise the protection may be affected. ◀

 Child restraint systems following an accident

Following an accident, all components of the child restraint system and the seat belt that was used to secure it should be checked and renewed if necessary.

This work should only be carried out by your Service Centre. ◀

For Australia/New Zealand Installation of child restraints

Please note the following warning because your vehicle has been equipped with a front airbag for the front passenger seat that cannot be deactivated:



It is recommended not to use any kind of child restraint system in the front passenger's seat.



Extreme hazard

Do not use a rearward facing child restraint on a seat protected by an airbag in front of it. ◀

Not for Australia/New Zealand: On the front passenger's seat

Deactivating airbags

Before fitting a child restraint in the front passenger's seat, make sure that the front and side airbags on the passenger's side are disabled.

Deactivating the front passenger airbags with key switch, see page 94.



Deactivating the front passenger airbags

If you fit a child restraint system in the front passenger's seat, the front passenger airbags must be deactivated, otherwise a child travelling on that seat will face an increased risk of injury if the airbags are deployed, even if a child restraint system is used. ◀

Seat position and height

Before mounting a universal child restraint, bring the front passenger's seat to the rearmost and the uppermost position to achieve the best possible routing of the belt and protection in the event of an accident.

Do not change this seat position and height.

Backrest width

With adjustable backrest width: before fitting a child restraint system in the front passenger's seat, fully open the backrest width. Do not

change the backrest width from this point on and do not call up a memory position.



Backrest width for child's seat

Before fitting a child restraint system in the front passenger's seat, the backrest width must be fully open. Do not change the setting while the child restraint system is fitted, as otherwise the stability of the child's seat will be restricted. ◀

ISOFIX child seat mountings

Note

Note for Australia: ISOFIX child seats are not allowable for road use in Australia at the time of printing of this handbook. However, also since a change of the respective regulations is expected for the future, lower ISOFIX anchorages are supplied in line with applicable ADRs also for Australia.



Manufacturer specifications for ISOFIX child restraints

For fitting and using ISOFIX child restraints, observe the operating and safety instructions of the system's manufacturer, as the protective effect could otherwise be impaired. ◀

Suitable ISOFIX child restraints

The following ISOFIX child restraints may be used in the rear seats. The corresponding classes are located on the child seats as letters or ISO specifications.

On the Rear Seat

A - ISO/F3	C - ISO/R3
B - ISO/F2	D - ISO/R2
B1 - ISO/F2X	E - ISO/R1
F - ISO/L1	G - ISO/L2

Brackets for lower ISOFIX anchors

 Properly engage the lower ISOFIX anchors

Make sure that the lower ISOFIX anchors are correctly locked in place and that the child restraint system is seated firmly against the backrest, as otherwise the protective effect can be diminished. ◀

Before fitting ISOFIX child restraints, pull the belt away from the area of the child seat mountings.

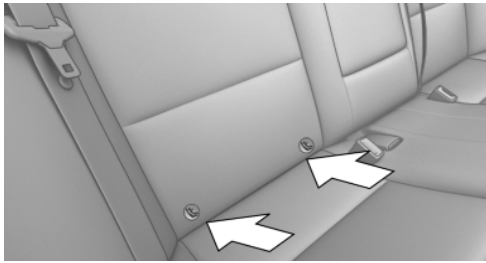

The brackets for the lower ISOFIX anchors are located in the gap between the seat and backrest.

Fitting ISOFIX child restraint systems

1. Fit the child restraint system, see instructions of the system.
2. Make sure that both ISOFIX anchors have snapped into place.

Upper ISOFIX retaining strap

Mounting points

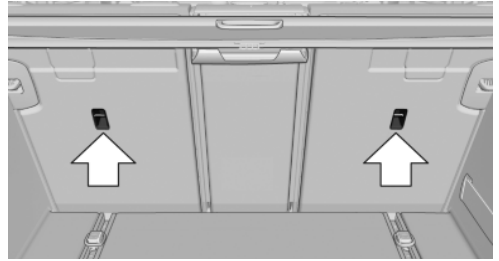

There are two mounting points for the upper retaining strap of ISOFIX child restraints.

 ISOFIX securing eyelets

Only use the fastening eyes of the upper ISOFIX holding belt for fastening child restraint systems, otherwise the fastening points may be damaged. ◀

Guide of the retaining strap

 Retaining strap

Make sure that the upper retaining strap is guided to the upper mounting point without touching the head restraint or sharp edges and it is not twisted, otherwise the seat belt cannot secure the child restraint appropriately in the event of an accident. ◀

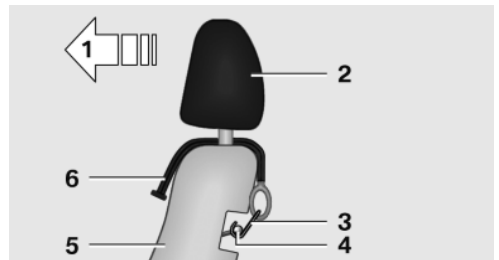

- 1 Direction of travel
- 2 Head restraint
- 3 Hook for the upper retaining strap
- 4 Mounting point/eyelet

- 5 Seat backrest
- 6 Upper retaining strap

Attach the upper retaining strap to the mounting point

1. Raise or remove the head restraint as necessary.
2. Guide the upper retaining strap between the head restraint mounts.
3. Engage the hook of the retaining strap in the securing eyelet.
4. Pull the restraining strap firmly down.
5. Lower and engage the head restraint as necessary.

For Australia/New Zealand: Child restraints

Notes

In accordance with ADR 34/01, provisions have been made to allow installation of a child restraint at each rear seating position.

The anchoring hooks which belong to the upper restraining strap of the child restraint - AS 1754, can be applied immediately to the relevant mounting.

Please refer strictly to the installation instructions supplied with the child restraint system.

Each seating position is fitted with a head rest.



Warning

Child restraint anchorages are designed to withstand only those loads imposed by correctly fitted child restraints. Under no circumstances are they to be used for adult seat belts, harnesses or for attaching other items or equipment to the vehicle. After using and removing child restraints, fold away the anchor brackets if necessary. ◀

Mounting points

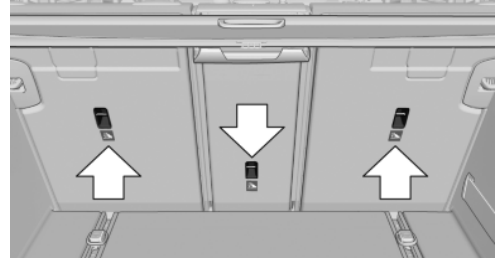

There are three mounting points for the upper retaining strap of ISOFIX child restraints.

Guide of the retaining strap



Retaining strap

Make sure that the upper retaining strap is guided to the upper mounting point without touching the head restraint or sharp edges and it is not twisted, otherwise the seat belt cannot secure the child restraint appropriately in the event of an accident. ◀

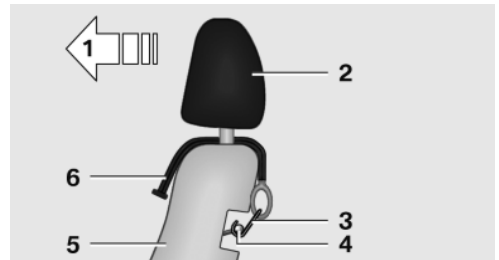

- 1 Direction of travel
- 2 Head restraint
- 3 Hook for the upper retaining strap
- 4 Mounting point/eyelet
- 5 Seat backrest
- 6 Upper retaining strap

Attach the upper retaining strap to the mounting point

1. Raise or remove the head restraint as necessary.
2. Guide the upper retaining strap between the head restraint mounts.
3. Engage the hook of the retaining strap in the securing eyelet.
4. Pull the restraining strap firmly down.
5. Lower and engage the head restraint as necessary.

Securing doors and windows

Rear doors

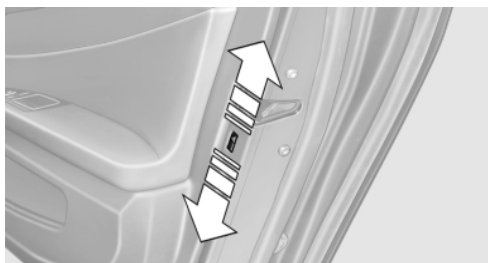

Push down the locking levers on the rear doors. The door in question can now only be opened from the outside.

Safety switch for the rear



Press the button on the driver's door if children are travelling in the rear.

Various functions are blocked and cannot be operated in the rear, safety switch, see page 41.

Driving

Vehicle Equipment

This chapter describes all standard, national and special equipment provided in the model series. Therefore equipment not available in a vehicle is also described, for example the selected special equipment or national version. That also applies to safety-relevant functions and systems.

Start/stop button

Principle



The ignition is switched on or off and the engine is started by pressing the start/stop button.

Automatic transmission: The engine starts if the brakes are applied when the start-stop button is pressed.

Manual transmission: The engine starts when the brake is applied when pressing the start/stop button.

Ignition on

Automatic transmission: Press the start/stop button without applying the brakes.

Manual transmission: Press the start/stop button, do not apply the clutch.

All systems are ready to operate.

Most of the indicator and warning lights in the instrument cluster are illuminated for different lengths of time.

To save battery power when the engine is off, switch off the ignition and any unnecessary electronic systems.

The ignition switches off automatically:

- ▶ If the vehicle is locked and the low-beam headlights are switched on.

- ▶ Shortly before the battery is discharged so that an engine start remains possible.
- ▶ If the engine is switched off and the ignition is switched on, the radio ready state will be automatically activated when the door is opened if the light is not illuminated or the daytime driving lights are illuminated.

Ignition off

Automatic transmission: Press the start/stop button again without applying the brakes.

Manual transmission: Press the start/stop button again, do not apply the clutch.

All indicator lights in the instrument cluster extinguish.

To save battery power when the engine is off, switch off the ignition and any unnecessary electronic systems.



Transmission position P with the ignition switched off

With the ignition switched off, transmission position P is engaged automatically. Make sure that in a car wash, for example, the ignition is not switched off inadvertently. ◀

Ignition automatically switches off with a stationary vehicle and engine shut off:

- ▶ When locking, even with the low-beam headlights switched on.
- ▶ Shortly before the battery is discharged so that an engine start remains possible. This function is only available with the low-beam headlights switched off.
- ▶ When opening and/or closing the driver's door, if the driver's belt is unfastened and the low-beam headlights are switched off.
- ▶ When the driver's belt is unfastened, if the driver's door is opened and the low-beam headlights switched off.

When switching off the ignition by opening or closing the driver's door or unfastening the driver's belt, the radio availability remains active.

Radio ready state

Activate radio ready state:

- ▷ Press the on/off button on the radio when the ignition is switched off.
- ▷ When the engine is running: press the start/stop button.

Individual electrical systems remain ready to operate.

Radio ready state switches off automatically:

- ▷ After approximately eight minutes.
- ▷ When locking via the central locking system.
- ▷ Shortly before the battery is discharged so that an engine start remains possible.

Engine start

Diesel engine

With the engine cold and at temperatures below approximately 0 °C, 32 °F, the starting operation can be delayed slightly due to automatic pre-heating.

A Check Control message is displayed.

Manual gearbox

Starting the engine

1. Press the brake.
2. Depress the clutch and engage idle position.
3. Press the start/stop button.

Starting proceeds for a certain time automatically and stops as soon as the engine is started.

Automatic gearbox

Starting the engine

1. Press the brake.
2. Press the start/stop button.

Starting proceeds for a certain time automatically and stops as soon as the engine is started.

Stopping the engine

General



Removing the remote control

To avoid the risk of children starting the engine, always take the remote control with you when you leave the car. ◀



Apply the parking brake and further secure the vehicle as required

When parking, apply the parking brake firmly to prevent the car from rolling. On steep upward and downward inclines, further secure the vehicle, for example, by turning the steering wheel in the direction of the curb. ◀

Before entering a car wash

So that the vehicle can roll into the car wash, follow the information on washing in an automatic car wash, see page 277.

Manual gearbox

Stopping the engine

1. Press the Start/Stop button when the vehicle is at standstill.
2. Engage first gear or reverse.
3. Apply the parking brake.

Automatic gearbox

Stopping the engine

1. With car at a standstill, engage transmission position P.
2. Press the start/stop button.
The engine is switched off.
The radio ready state is switched on.
3. Apply the parking brake.

Auto Start Stop function

Principle

The Auto Start Stop function helps you to save fuel, by stopping the engine when stationary, for example, in a traffic jam or at traffic lights. The ignition remains switched on. For driving off, the engine starts automatically.

Automatic operation

After every time you start the engine, the Auto Start Stop function is operational.

The function is activated from a certain speed:

- ▷ Manual gearbox: from 5 km/h, 3 mph.
- ▷ Automatic transmission: from 9 km/h, approximately 5 mph.

Stopping the engine

The engine is automatically shut down when stationary under the following conditions:

Manual gearbox:

- ▷ Transmission in neutral and clutch pedal not pressed.
- ▷ Driver's seat belt buckled or driver's door closed.

Automatic gearbox:

- ▷ Selector level in gear position D.
- ▷ Brake pedal remains depressed while the vehicle is at a standstill or vehicle is kept stationary by Automatic Hold.
- ▷ Driver's seat belt buckled or driver's door closed.

The air flow rate of the air conditioning system is reduced when the engine is not running.

Displays in the instrument cluster



The display indicates that the Auto Start Stop function is ready for automatically starting the engine.

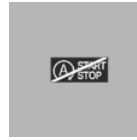

The display indicates that the preconditions for an automatic engine stop are not met.

Note

The engine is not shut down automatically in the following situations:

- ▷ Ambient temperature below approximately +3 °C/+37 °F.
- ▷ High outside temperature and operation of the automatic air conditioning.
- ▷ Interior not heated or cooled to the desired temperature.
- ▷ Engine is not yet at operating temperature.
- ▷ Sharp steering angle or steering operation.
- ▷ After reversing.
- ▷ Condensation when the automatic air conditioning is switched on.
- ▷ Vehicle battery in a low state of charge.
- ▷ Bonnet is unlocked.
- ▷ HDC is activated.
- ▷ Stop/go traffic.
- ▷ Gear selector lever in N or S/M position.

Engine start

For driving off, the engine automatically starts under the following conditions:

- ▷ Manual gearbox:
Clutch pedal is depressed.
- ▷ Automatic gearbox:
By releasing the brake pedal.
With activated Automatic Hold: depress the accelerator.

After starting the engine, accelerate as normal.

Safety function

After an automatic shut down, the engine will not restart automatically if one of the following conditions is satisfied:

- ▷ Driver's seat belt unbuckled and driver's door open.
- ▷ Bonnet has been unlocked.

Several indicator lights illuminate for various lengths of time.

The engine can only be started using the start/stop button.

Note

Even if you do not want to drive off, the engine restarts automatically in the following situations:

- ▷ Very high temperature inside the passenger compartment, if the cooling function is on.
- ▷ The driver applies lock to the steering wheel.
- ▷ Automatic transmission: change the gear position from D to N, R or M/S.
- ▷ Automatic transmission: change the gear position from P to N, D, R or M/S.
- ▷ Vehicle starts to roll.
- ▷ Condensation when the automatic air conditioning is switched on.
- ▷ Vehicle battery in a low state of charge.
- ▷ Very low temperature inside the passenger compartment, if the heating is on.
- ▷ Low brake vacuum, for example because the brake pedal has been depressed a number of times in succession.

Preventing automatic engine stop with automatic transmission

Principle

To enable the vehicle to move off particularly swiftly, for example at a junction, the automatic engine stop can be actively prevented.

Preventing automatic engine stop using the brake pedal

The engine stop can be actively prevented within a second of the vehicle coming to a standstill:

- ▷ Press the brake pedal down firmly as soon as the vehicle has come to a standstill.
- ▷ Then immediately brake again with normal braking force.

Manually deactivating/activating the system

Using the button



Press the button.

- ▷ LED illuminates: Auto Start Stop function is deactivated.
During an automatic engine stop, the engine is started.
The engine can be started or stopped only by means of the start/stop button.
- ▷ LED goes out: Auto Start Stop function is activated.

Parking the vehicle during automatic engine stop

With automatic engine stop, the vehicle can be parked safely, for example in order to leave it.

1. Press the start/stop button. The ignition is switched off. The Auto Start Stop function is deactivated.
Automatic transmission: transmission position P is automatically engaged.
 2. Apply the parking brake.
- Start engine as usual, using the start/stop button.

Automatic deactivation

In certain situations the Auto Start Stop function is deactivated automatically for safety's sake, for example if the absence of the driver is detected.

Malfunction

The Auto Start Stop function no longer shuts down the engine. A Check Control message is displayed. It is possible to keep driving. Have the system checked.

Parking brake

Principle

The parking brake is used to prevent the vehicle from rolling when it is parked. It acts on the rear wheels.



Engaging

 Pull switch.
LED is illuminated.

 The indicator light illuminates red. The parking brake is engaged.

 Apply the parking brake and further secure the vehicle as required

When parking, apply the parking brake firmly to prevent the car from rolling. On steep upward and downward inclines, further secure the vehicle, for example, by turning the steering wheel in the direction of the curb. ◀

While the vehicle is in motion

Use while the vehicle is in motion, serves as an emergency brake:

Pull and hold the switch. The vehicle brakes strongly for as long as the button is pulled.

 The indicator light illuminates red, a signal sounds and the brake lights illuminate.

If the vehicle is braked to approximately 3 km/h, 2 mph, the parking brake remains engaged.

Releasing

With the ignition switched on:

 Manual gearbox: Press the switch with the brake or clutch pressed.

Automatic transmission: Press the switch with the brake pressed or gearbox position P engaged.

LED and indicator turn off.

Parking brake is released.

Automatic release for automatic gearbox

Operate the accelerator pedal to automatically release.

LED and indicator turn off.

Under the following conditions, the parking brake is automatically released by operating the gas pedal.

- ▷ Engine on
- ▷ Drive stage engaged
- ▷ Driver belted in and doors closed

 Unintentional operation of the gas pedal
Ensure that the gas pedal is not unintentionally operated, otherwise, the vehicle will start to move and there is a risk of accident. ◀

Automatic Hold

Principle

This system automatically applies and releases the brake, for example in stop/go traffic.

The vehicle is automatically held at a standstill.

On upward inclines, rolling back is prevented when driving off.



For your safety

Under the following conditions, Automatic Hold is automatically disabled and the parking brake is engaged:

- ▷ The engine is switched off.
- ▷ A door is opened when stationary and the seat belt of the driver is unfastened.
- ▷ The parking brake is used to brake to a standstill while the vehicle is in motion.

 Indicator light changes from green to red and the lettering AUTO H is deactivated.

Before driving off:

- ▷ Release the parking brake manually.
- ▷ Reactivate Automatic Hold.

 Leaving the vehicle with engine running
Before leaving the vehicle with the engine running, engage position P of the automatic transmission and ensure that the parking brake is engaged. The car could otherwise start to move. ◀

Activating

Activation is possible when the driver's door is closed and the seat belt is fastened and during the journey.

 Press the button.

The LED and lettering AUTO H are illuminated.

 Indicator light is illuminated.

Automatic Hold is activated.

Deactivating

 Press the button again.

The LED and lettering AUTO H are deactivated.

Automatic Hold is deactivated.

If the vehicle is being kept stationary by Automatic Hold, apply the brake to deactivate.

If the parking brake is applied manually, Automatic Hold is automatically disabled.

Driving

When Automatic Hold is activated, the vehicle is automatically secured against rolling whenever it stops.

 The indicator light illuminates green.

To move off, press the accelerator.

The brake is released automatically.

Indicator light turns off.

 Before entering a car wash

Deactivate Automatic Hold, as otherwise the parking brake is applied when the vehicle is stationary and the vehicle can no longer roll. ◀

Parking

The parking brake is automatically applied when the vehicle is held by Automatic Hold and the engine is switched off.



The indicator light changes from green to red.

The parking brake is not applied if the engine was switched off while the vehicle was still rolling. Automatic Hold is disabled.

During an engine stop due to the Auto Start Stop function, Automatic Hold remains activated.



Removing the remote control

To avoid the risk of children releasing the parking brake, always take the remote control with you when you leave the car. ◀

Malfunction

If the parking brake fails or malfunctions, secure the vehicle against rolling away, for example with a chock, if you leave the vehicle.

Turn indicators, high-beam headlights, headlight flasher

Turn indicator

Indicating

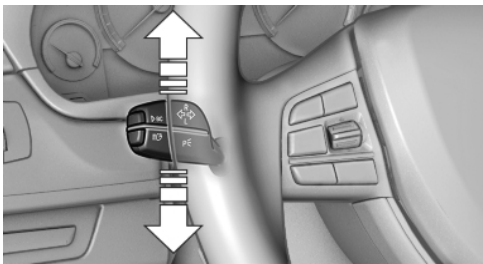

Press the lever beyond the resistance point. To cancel the signal manually, press the lever as far as the resistance point.

If the indicator light flashes more rapidly than usual, a turn indicator bulb has failed.

During trailer towing, the light might also indicate failure of one of the turn signal lights of the trailer.

Triple turn signal

Press the lever as far as the resistance point.

The turn indicator flashes three times.

This function can be enabled or disabled.

1. "Settings"
2. "Lights"
3. "Triple turn signal"

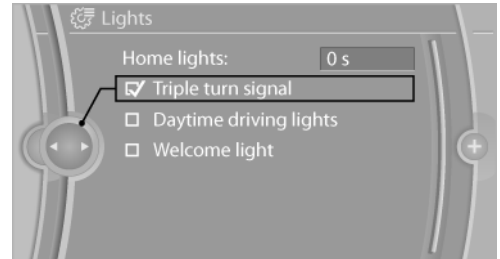

Indicating a turn briefly

Press the lever as far as the resistance point and hold it there for as long as you wish to indicate a turn.

High-beam headlights, headlight flasher

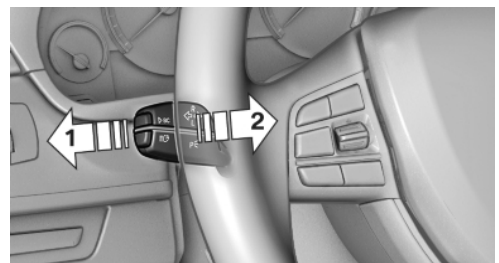

- ▷ High-beam headlights, arrow 1.
- ▷ Headlight flasher, arrow 2.

Wiper system

Switching the wipers on/off and flick-wiping

 No wiper operation in the event of frost
Do not switch on the wipers when they are frozen, as otherwise the wiper blades and windscreen wiper motor can be damaged. ◀

Switch on

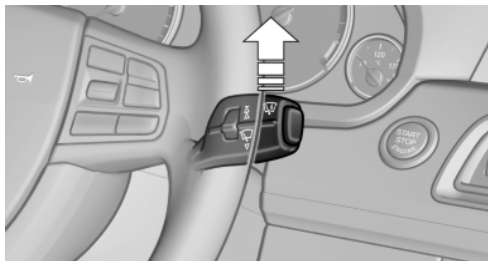

Press the wiper lever upwards.

The lever returns to the basic position when released.

- ▷ Normal wiping speed: press upwards once.
When the vehicle is stationary, the wipers switch to intermittent operation.
- ▷ Rapid wiping speed: press upwards twice or press once beyond the resistance point.
When the vehicle is stationary, the wipers switch to normal speed.

Switching off and flick-wiping

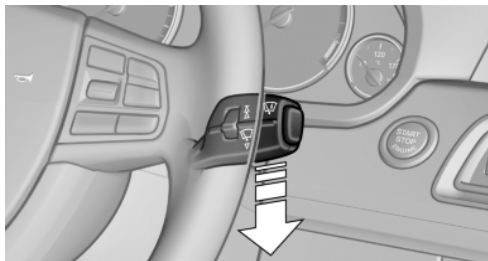

Press the wiper lever downwards.

The lever returns to the basic position when released.

- ▷ Flick-wiping: press downwards once.
- ▷ Switching off normal mode: press downwards once.
- ▷ Switching off fast mode: press downwards twice.

Intermittent operation or rain sensor

Principle

The rain sensor automatically controls the wiper operation depending on the rain intensity. The sensor is mounted on the windscreen, directly in front of the interior mirror.

Activating/deactivating

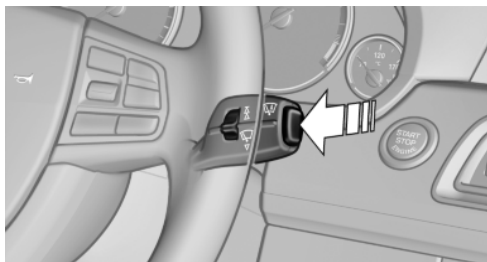

Press the button on the wiper lever.

The LED in the steering-column lever is illuminated.

 Disable the rain sensor in car washes
Deactivate the rain sensor in an automatic car wash to prevent the wipers from being activated inadvertently and damaged. ◀

Set interval time or sensitivity of the rain sensor

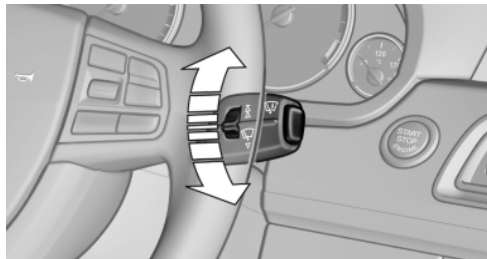

Turn the knurled wheel.

Cleaning the window glass, headlights

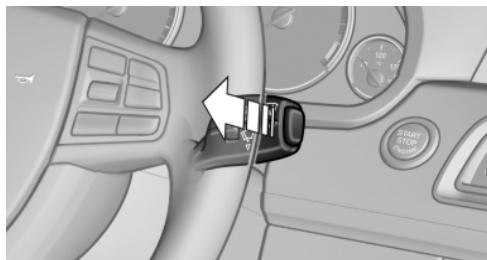

Pull the lever.

Fluid from the washer fluid reservoir is sprayed onto the windscreen and the wipers are operated briefly.

When the vehicle's lights are switched on, the headlights are also cleaned simultaneously at practical intervals.

⚠ Do not use the washer system in the event of frost

Only operate the washer systems and cleaning equipment if you are certain that the fluid will not freeze on the windscreen and interfere with the view ahead. Therefore, use anti-freeze.

Do not use the washer systems if the fluid reservoir is empty, or the washer pump will be damaged. ◀

Windscreen washer jets

Both windscreen washer jets are automatically heated when the ignition is switched on.

Switching on rear window wiper

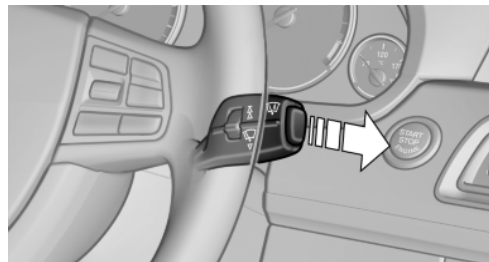

Push the lever forwards to activate intermittent operation. Engaging reverse gear activates continuous operation.

To clean the rear window push the lever further forward.

Fold-out position of the wipers

This is important, for example for replacing the wiper blades or folding them out in the event of frost.

1. Switch the ignition off.
2. If there is a risk of frost, make sure that the wiper blades are not frozen.
3. Press the wiper lever upwards beyond the resistance point and hold it there for approximately three seconds until the wipers come to a standstill in a nearly vertical position.

After folding the wipers in, the wiper system must be reactivated.

⚠ Folding the wipers onto the windscreen
Before switching on the ignition, fold the wipers onto the windscreen, as otherwise damage can occur when the wipers are switched on. ◀

1. Switch on ignition.
2. Press the wiper lever downwards. The wipers move to the rest position and are operational once again.

Washer fluid

General

 Anti-freeze protection for washer fluid

Anti-freeze is flammable. This is why it should be kept away from naked flames.

Only store in the sealed original container and out of reach of children.

Comply with the instructions on the container. ◀

Reservoir for washer fluid

 Topping up washer fluid

Only top up washer fluid when the engine has cooled down and then fully close the lid to prevent washer fluid from making contact with hot engine components.

Otherwise, if the fluid is spilled, there is a risk of fire and personal safety is endangered. ◀



All washer jets are supplied from one tank.

When filling with water, to which anti-freeze has been added if required, always follow the manufacturer's instructions.

Before topping up, mix the washer fluid to comply with the mixture ratio.

See technical data for capacity.

Manual gearbox

Shifting gears

 Shifting into the 5th/6th gear level

During the shifting process into 5th/6th gear level, push the gear shift lever to the right, otherwise, an inadvertent switching to the 3rd or 4th gear could lead to engine damage. ◀

Reverse gear

Engage this position only when the car is stationary. Overcome the resistance when pressing the gearshift lever to the left.

Automatic transmission with Steptronic

Transmission positions

D Drive, automatic position

Use this position for all normal driving. All forward gears are selected as necessary.

R Reverse

Engage this position only when the car is stationary.

N Neutral

Select this in a car wash, for example. The car will be able to roll.

With the ignition off, see page 59, transmission position P is engaged automatically.

P Park

Engage this position only when the car is stationary. The driven wheels are locked.

Transmission position P is engaged automatically:

- ▶ After stopping the engine in the radio ready state, see page 60, or ignition off, see page 59, when position R or D is engaged.

- ▷ Position N is engaged and ignition is off.
- ▷ If the vehicle is at a standstill and selector lever position R or D is engaged, the driver's side seat belt is stored, the driver's door is opened and the brake is not depressed.

Before leaving the vehicle, ensure that the automatic gearbox is engaged in the P position. The car could otherwise start to move.

Kick-down

Kick-down enables you to achieve maximum performance. Press the accelerator pedal down beyond the regular full-throttle position; resistance will be felt.

Engaging transmission positions

- ▷ It is only possible to move from transmission position P with the engine running and the brake pressed.
- ▷ Before shifting from P or N when the vehicle is stationary, first press the brake, otherwise the desired gearshift will not be performed: shiftlock.



Apply the brake until you are ready to move off

Apply the brake until you are ready to move off; this will prevent the car creeping when a gear is selected. ◀

Engage D, R, N

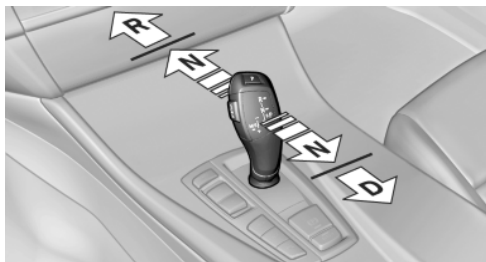

Briefly press the selector lever in the desired direction, possibly overcoming a resistance point.

When you let go of the selector lever, it returns to the central position.



Press the unlock button to:

- ▷ Engage R.
- ▷ Shift from P.

Engaging P



Press button P.

Sport program DS and M/S manual-shift mode

Activating the Sport program DS



Press the selector lever out of position D to the left.

DS is shown in the instrument cluster.

The Sport program of the gearbox is activated.

Activating M/S manual-shift mode

Press the selector lever out of position D to the left.

Press the selector lever forwards or backwards.

Manual operation becomes active and the gear is shifted.

The gear selected appears briefly on the instrument cluster, for example M1.

- ▷ To shift down: press the selector lever forwards.
- ▷ To shift up: press the selector lever backwards.

Upshifts and downshifts are performed only at suitable engine and road speeds; for example, the transmission will not shift down if the resulting engine speed would be too high.

The gear selected appears briefly on the instrument cluster, followed by the gear actually in use.

Manual shift mode M/S: avoiding automatically changing up

To reach the maximum the engine speed in manual shift mode M/S it automatically upshifts as needed.

With the sport automatic gearbox, these automatic shift processes are not carried out if one of the following conditions is met:

- ▷ DSC deactivated
- ▷ TRACTION activated
- ▷ SPORT+ activated

The Kick-down is also deactivated.

Switching off the Sport program/ manual operation

Press the selector lever to the right.

D is shown in the instrument cluster.

Shift paddles for sport automatic transmission

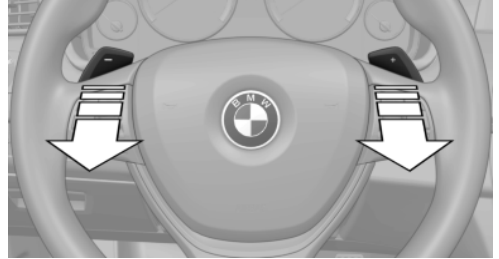

The shift paddles on the steering wheel enable fast gearshifting without taking the hands off the steering wheel.

If you switch gear with the shift paddles whilst in automatic mode, the vehicle switches to manual mode briefly.

If you neither shift with the shift paddles nor accelerate for a certain time, the vehicle changes back to automatic mode, provided the selector lever is in gear position D.

- ▷ Change up: pull right paddle.
- ▷ Change down: pull left paddle.

Upshifts and downshifts are performed only at suitable engine and road speeds; for example, the transmission will not shift down if the resulting engine speed would be too high.

The gear selected appears briefly on the instrument cluster, followed by the gear actually in use.

Displays in the instrument cluster



The gear box position is displayed, for example: P.

Displays

Vehicle Equipment

This chapter describes all standard, national and special equipment provided in the model series.

Therefore equipment not available in a vehicle is also described, for example the selected special equipment or national version. That also applies to safety-relevant functions and systems.

Instrument cluster

Overview

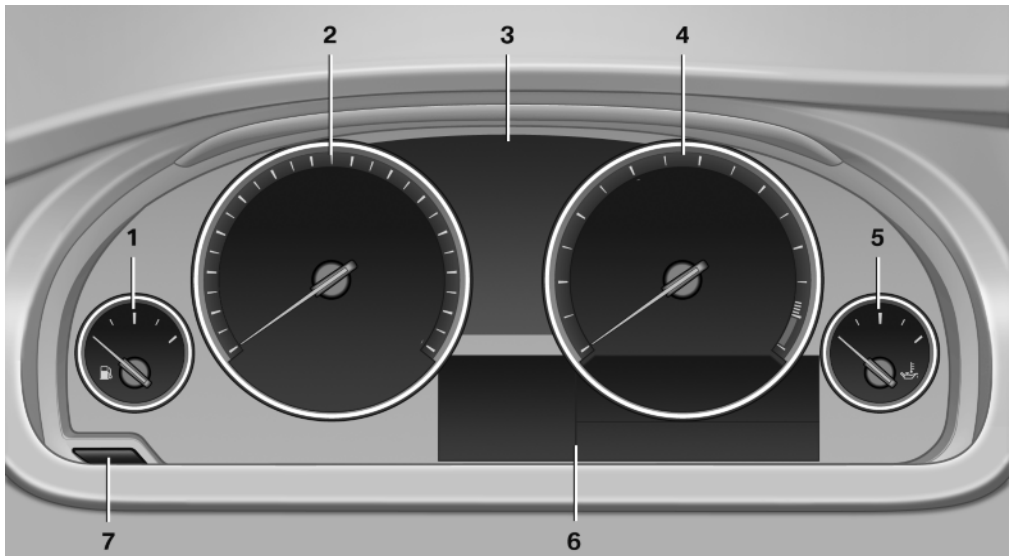

- | | |
|---|---|
| 1 Fuel gauge 75 | 5 Engine oil temperature 75 |
| 2 Speedometer | 6 Electronic displays 72 |
| 3 Indicator and warning lights 73 | 7 Reset kilometres 76 |
| 4 Revolution counter 75 | |

Electronic displays

With Professional navigation system or television, TV

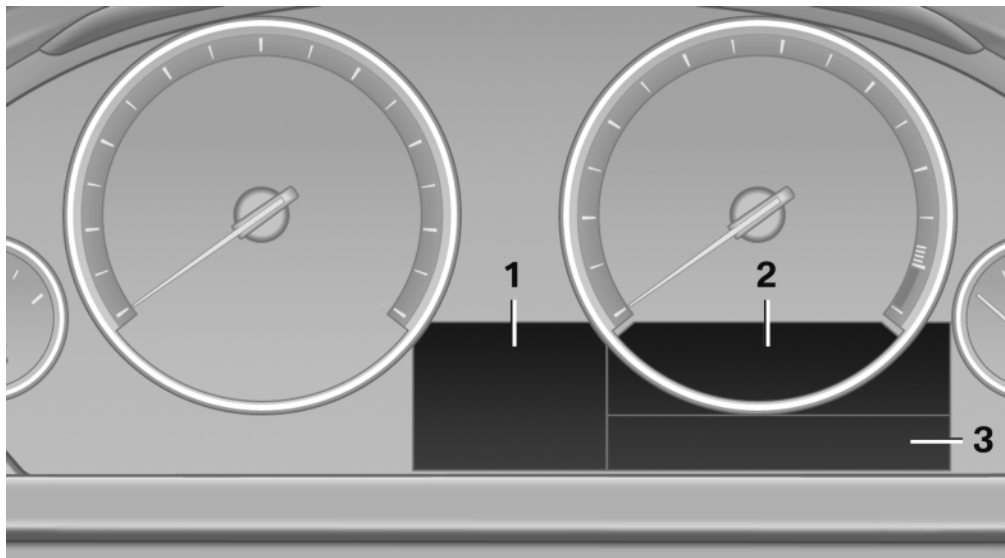

- 1** Selection list, for example radio [80](#)
Navigation display [154](#)
Speed Limit Information [78](#)

- On-board computer [80](#)
- 2** Transmission displays [70](#)
- 3** Service requirements [77](#)
Messages, for example, Check Control [73](#)

With Business navigation system or without navigation

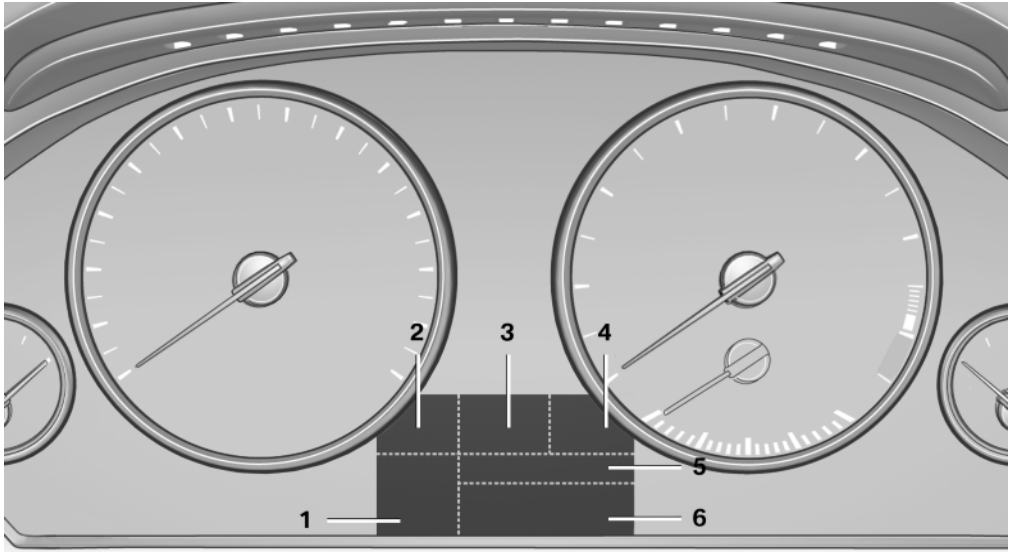

- | | |
|---|---|
| <p>1 Clock 76
Outside temperature 76</p> <p>2 Messages, for example, Check Control 73</p> <p>3 Transmission displays 70</p> | <p>4 List boxes, for example, Dynamic Driving Control 80</p> <p>5 On-board computer 80</p> <p>6 Service requirements 77</p> |
|---|---|

Check Control

Principle

The Check Control monitors vehicle functions and alerts you to any faults in the monitored systems.

A Check Control message is displayed as a combination of indicator or warning lights and text messages in the instrument cluster and the Head-Up Display.

If applicable, the text message shown in the control display is accompanied by an additional acoustic sound.







Indicator and warning lights







Indicator and warning lights can illuminate in a variety of combinations and colours.

When the engine starts or the ignition is switched on, the functionality of some lights is briefly checked.

Overview: indicator and warning lights

Symbol	Function or system
	Turn indicator
	Parking brake
	Automatic Hold
	Front fog lights
	Rear fog light
	High-beam headlights
	High-beam assistance
	Side lights, low-beam headlights
	Lane departure warning
	Dynamic Stability Control, DSC
	Dynamic Stability Control, DSC, or Dynamic Traction Control, DTC
	Runflat indicator
	Seat belts
	Airbag system

Symbol Function or system

	Steering system
	Emissions
	Brake system
	Anti-lock Brake System, ABS
	At least one Check Control message is displayed or stored

Text messages

Text messages and symbols in the instrument cluster explain the meaning of a Check Control message.



Supplementary text messages

You can call up additional information, for example the cause of the fault and any action required, via Check Control.

The supplementary text is automatically shown in the Control Display for urgent messages.

Symbols

Inside the extended text message, depending on the Check Control message, the following functions can be selected.

- ▶  Display additional information on the Check Control message in the integrated Owner's Handbook.
- ▶  "Service request"
Contact the Service Partner.
- ▶  "BMW Mobile Care"
Contact the Mobile Service.

Hiding Check Control messages

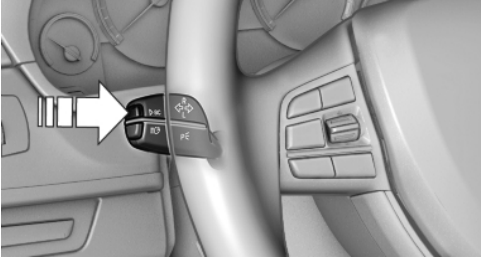

Press the on-board computer button on the turn indicator lever.

- ▶ Some Check Control messages are displayed permanently and remain until the fault has been repaired. If there are a number of malfunctions simultaneously, the messages are displayed in succession.

These messages can be hidden for approximately eight seconds. They are then displayed again automatically.

- ▶ Other Check Control messages are automatically hidden after approximately 20 seconds. They remain saved and can be displayed again.

Displaying Check Control messages saved in memory

1. "Vehicle information"
2. "Vehicle status"
3.  "Check Control"
4. Select a text message.

Messages displayed at the end of a journey

Special messages displayed when driving are displayed again when the ignition is switched off.

Fuel gauge



Vehicle incline can lead to fluctuations in the display.

Notes on refuelling, see page [242](#).

Revolution counter



It is vital to avoid engine speeds in the red warning zone. In this zone, the fuel supply is interrupted to protect the engine.

Engine oil temperature



- ▶ Cold engine: the pointer is located at a low temperature value. Drive at moderate engine and road speeds.

- ▶ Normal operating temperature: the needle is located in the centre or left half of the temperature display.

- ▶ Hot engine: the pointer is located at a high temperature value. A Check Control message is also displayed.

Coolant temperature

If the coolant and therefore the engine become too hot, a Check Control message is displayed.

Check coolant level, see page [259](#).

Odometer and trip distance recorder

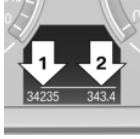

- ▷ Odometer, arrow 1.
- ▷ Trip distance recorder, arrow 2.

Reset trip distance recorder



- Press the button.
- ▷ When the ignition is off, the odometer is displayed.
 - ▷ When the ignition is on, the trip distance recorder is reset.

Outside temperature

Outside temperature warning

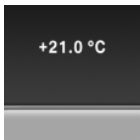

If the display falls to +3 °C/+37 °F, a signal sounds.

A Check Control message is displayed.

There is an increased risk of black ice.

Danger of icy roads

Even at temperatures above +3 °C/+37 °F, there can be an increased danger of icy roads.

To reduce the risk of an accident, you should always drive carefully in potentially icy areas, for example bridges and shaded roads. ◀

Time

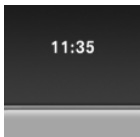

The time is shown in the instrument cluster.

Setting the time on the control display, see page 83.

Date

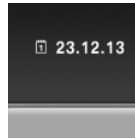

The date is displayed on the instrument cluster.

Setting the date on the control display, see page 83.

Range

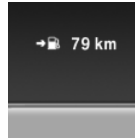

Once the reserve level is reached:

- ▷ A Check Control message is briefly displayed.
 - ▷ The on-board computer shows the remaining range.
- ▷ With, for instance, fast cornering, the engine function is not always ensured.

If the range drops below approx. 50 km, 30 miles the Check Control message is continually displayed.



Refuel in good time

If the range drops below 50 km, 30 miles, you should refuel as soon as possible, or engine function may be impaired and damage may occur. ◀

Displaying the range

1. "Settings"
2. "Info display"
3. "Additional indicators"

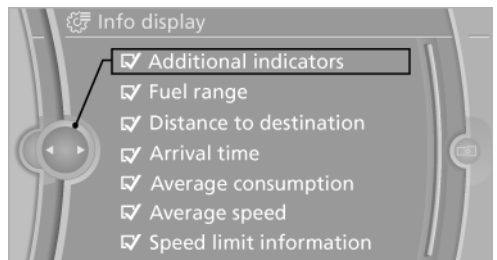

Current fuel consumption



Shows the momentary fuel consumption. It is possible to check the economy and environmental compatibility of your driving style.

Displaying the current fuel consumption

1. "Settings"
2. "Info display"
3. "Additional indicators"

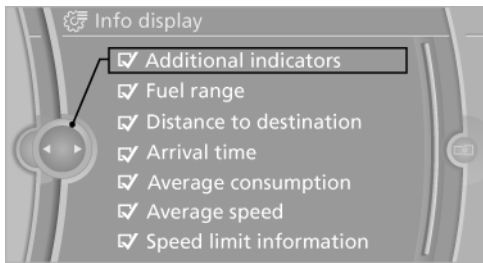

The bar gauge for the current fuel consumption is shown in the instrument cluster.

Energy recuperation

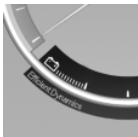

In the coasting mode, the kinetic energy of the vehicle is converted into electrical energy. The vehicle battery is partially charged and fuel consumption can be lowered.

ered.

Service requirements

Display



The distance to be driven or time to the next maintenance is displayed briefly after switching on the ignition.

The current service requirements can be read by the service advisor from the remote control.

The data regarding the service status of your vehicle or regarding legally prescribed inspections are transferred automatically before the due date to the Service centre, Automatic Service Notification, see page 230.



Detailed information on service requirements

More detailed information on the scope of maintenance can be displayed on the control display.

1. "Vehicle information"
2. "Vehicle status"
3.  "Service required"

Essential maintenance routines and any statutory inspections required are displayed.
4. Select an entry to display more detailed information.

Symbols

Symbols	Description
	No servicing is currently needed.
	Servicing or an inspection required by law is due soon.
	Servicing is overdue.

Entering deadlines

Enter deadlines for prescribed statutory inspections.

Ensure that the date and time of the vehicle are set correctly.

1. "Vehicle information"
2. "Vehicle status"
3.  "Service required"
4. "§ vehicle inspection"
5. "Date:"
6. Make the settings.
7. Confirm.

The date input is saved.

Automatic Service notification

Data on the service status or on statutory inspections for the vehicle are transmitted to the Service centre automatically when a service or inspection is imminent.

It can be checked when the Service centre was notified.

1. "Vehicle information"
2. "Vehicle status"
3. Call up "Options".
4. "Last Teleservice Call"





Shift point indicator

Principle

The system recommends the most efficient gear for the current driving situation.

Displays

Instructions on up or downshifting are displayed on the instrument cluster.

Symbols	Description
	Most efficient gear is engaged.
	Shift up into most efficient gear.
	Shift down into most efficient gear.
	Shift to neutral.

Speed Limit Information with No Passing Information

Principle

Speed Limit Information

Speed Limit Information displays using a symbol in the shape of a traffic sign in the instrument cluster, the currently detected speed limit. The camera in the base of the rear view mirror records the traffic signs on the verge as well as variable displays on overhead gantries. Traffic signs with additional symbols, for example, when wet, are also compared with data internal to the vehicle, for example the rain sensor, and displayed, depending on the situation. The system considers the information stored in the navigation system and also displays the speed limits present on unmarked sections of road.

No Passing Information

No Passing Information displays with corresponding symbols in the instrument cluster no passing restrictions and their removal detected by the camera. The system only considers no passing restrictions and lifting the restriction made known by signage.

No display:

- ▷ In countries in which no passing is primarily shown by road markings.
- ▷ On routes without signage.
- ▷ On level crossings, carriageway markings or other situations which would not indicate an unsigned no passing restriction.

Switching on/off

1. "Settings"
2. "Info display"
3. "Speed limit information"

If Speed Limit Information is switched on, this can be displayed through the on-board computer to the information display in the instrument cluster. No Passing Information is displayed together with activated Speed Limit Info.

Display

The following information appears in the instrument cluster.

Speed Limit Information

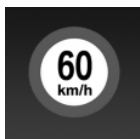

- ▷ Present speed limit.
- ▷ Speed limit cancelled - for German motorways.
- ▷ Speed limit information unavailable.

The Speed Limit Information can also be displayed in the Head-Up Display.

No Passing Information



- ▷ No passing restriction.
- ▷ End of no passing restriction.
- ▷ No Passing Information unavailable.

The No Passing Information can also be shown in the Head-Up Display.

System limits



Personal assessment

The system is no substitute for your personal assessment of the traffic situation.

The system supports the driver and does not replace the human eye. ◀

The function may be disabled or inaccurate under certain conditions, for example:

- ▷ In thick fog and heavy rain or snow.
- ▷ If road signs are obscured.
- ▷ If the vehicle is moving too close to the vehicle ahead.
- ▷ With bright light from oncoming traffic.
- ▷ When the windscreen in front of the interior mirror is covered with condensation, dirt, stickers, labels, etc.
- ▷ Due to possible wrong detections of the camera.
- ▷ If the speed limits stored in the navigation system are wrong.
- ▷ In areas not covered by the navigation system.
- ▷ If there are deviations in relation to the navigation, for example due to changes in the road routing.
- ▷ On overtaking buses or trucks with speed stickers.
- ▷ If traffic signs do not correspond to the standard.
- ▷ During the calibration process of the camera immediately after the vehicle is supplied.

Camera

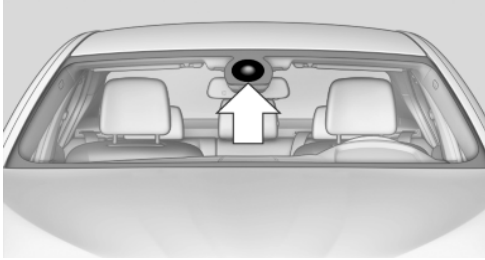

The camera is in the area of the base of the mirror.

Keep the windscreen clean and clear in the area in front of the rear view mirror.

Selection lists in the instrument cluster

Principle



The following can be operated via the buttons and the knurled wheel on the steering wheel using the display in the instrument cluster:

- ▷ Current audio source.
- ▷ Repeat dialling for telephone.
- ▷ Activating the voice control system.

Activating the list and entering a setting

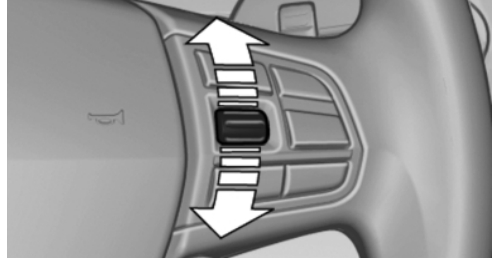

Turn the knurled wheel on the right-hand side of the steering wheel to activate the corresponding list.

Using the knurled wheel, select the desired setting and confirm by pressing the knurled wheel.

On-board computer

Calling up information on the information display

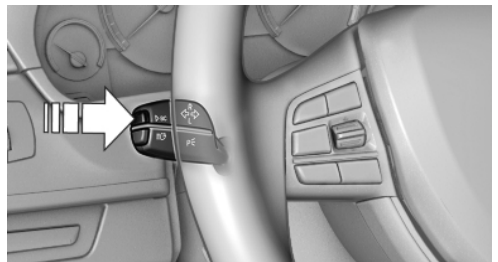

Press the on-board computer button on the turn indicator lever.

Information is displayed on the information display in the instrument cluster.

Overview of the information

Info display

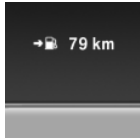

Repeated pressing of the button on the turn indicator lever shows the following information on the information display:

▷ Range.

- ▷ ECO PRO bonus range.
- ▷ Average fuel consumption.
- ▷ Current consumption.
- ▷ Average speed.
- ▷ Date.
- ▷ Time of arrival.

With activated route guidance in the navigation system.

- ▷ Distance to destination

With activated route guidance in the navigation system.

- ▷ Arrow display of the navigation system.

With activated route guidance in the navigation system.

If the arrow view in the head up display is not active.

Setting displays for the information display

It can be set which displays of the on-board computer can be called up on the information display in the instrument cluster.

1. "Settings"
2. "Info display"

3. Select the desired displays.

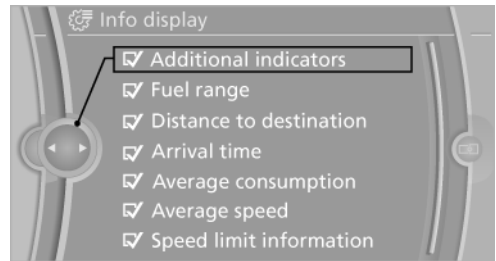

Detailed information

Range

Displays the estimated range available with the remaining fuel.

It is calculated based on your driving style over the last 30 km, 20 miles.

Average fuel consumption

Calculated for the period since the engine was last started.

The average fuel consumption is calculated on the basis of various distances.

Average speed

The calculation of average speed ignores any stationary periods where the engine was switched off manually.

Resetting average values

Keep the on-board computer button pressed on the turn indicator lever.

Distance to destination

The remaining distance to the destination is displayed if a destination was entered in the navigation system before starting the journey.

The distance to the destination is automatically adopted.

Arrival time

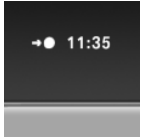

The provisional arrival time is displayed if a destination was entered in the navigation system before starting the journey.

A precondition is that the time is correctly set.

Speed Limit Information

Description of speed limit information, see page 78

Speed limit

Display of a speed limit where a warning is to be issued when reached.

Repeat warning if the set speed limit was undershot once by at least 5 km/h, 3 mph.

Displaying, setting or altering limit

1. "Settings"
2. "Speed"
3. "Warning at:"

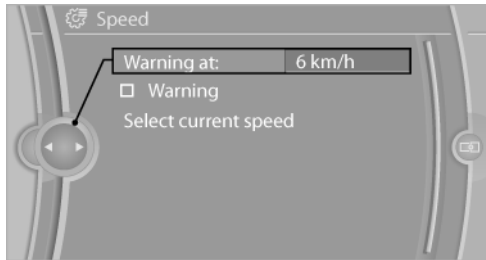

4. Turn the controller until the desired limit is displayed.

5. Press the controller.

The speed limit is saved.

Activating/deactivating the speed limit

1. "Settings"
2. "Speed"
3. "Warning"
4. Press the controller.

Saving actual speed as limit value

1. "Settings"
2. "Speed"
3. "Select current speed"
4. Press the controller.

The current driving speed is saved as the limit.

Journey computer

Two types of on-board computer are available.

- ▷ "On-board computer": values can be reset any number of times.
- ▷ "Journey computer": values deliver an overview of the current trip.

Resetting the journey computer

1. "Vehicle information"
2. "Journey computer"
3. "Reset": all values are reset.

"Reset automatically": all values are reset if the vehicle is at a standstill for approximately four hours.

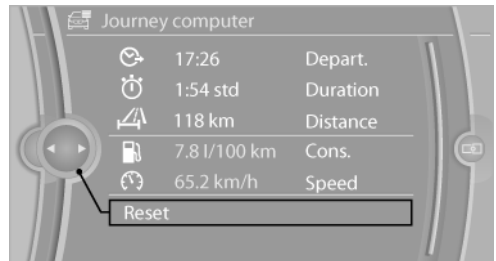

Display on the control display

Display the on-board computer or journey computer on the control display.

1. "Vehicle information"
2. "On-board computer" or "Journey computer"

Resetting fuel consumption and speed

1. "Vehicle information"
2. "On-board computer"
3. "Cons." or "Speed"



4. "Yes"

Settings on the control display

Time

Setting the time zone

1. "Settings"
2. "Time/Date"
3. "Time zone"
4. Select desired time zone.

The time zone is saved.

Setting the time

1. "Settings"
2. "Time/Date"
3. "Time:"

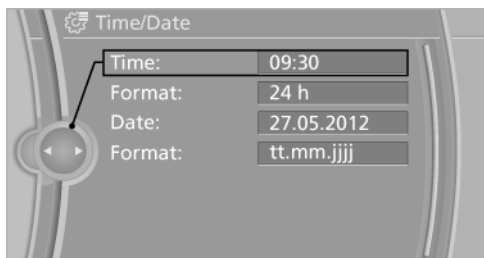

4. Turn the controller until the desired hours are displayed.
 5. Press the controller.
 6. Turn the controller until the desired minutes are displayed.
 7. Press the controller.
- The time is saved.

Setting the time format

1. "Settings"
 2. "Time/Date"
 3. "Format:"
 4. Select the desired format.
- The time format is saved.

Date

Setting the date

1. "Settings"
2. "Time/Date"
3. "Date:"
4. Turn the controller until the desired day is displayed.
5. Press the controller.
6. Make the setting for month and year accordingly.

The date is saved.

Setting the date format

1. "Settings"
2. "Time/Date"

3. "Format:"
4. Select the desired format.



The date format is saved.

Language

Setting the language

To set the language on the control display:

1. "Settings"
2. "Language/Units"
3. "Language:"

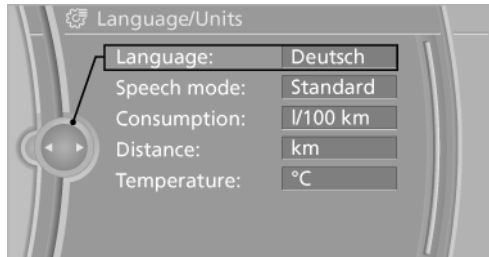

4. Select the desired language.

The setting is saved for the remote control currently in use.

Setting the speech dialogue

Voice dialogue for the voice entry system, see page 22.

Units of measure

Setting the units of measure

To set the units of measure for fuel consumption, distance covered/remaining range, and temperature:

1. "Settings"
2. "Language/Units"
3. Select the desired menu item.

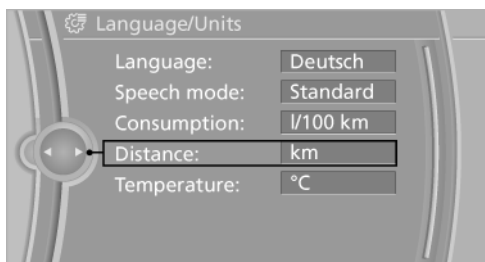

4. Select the desired unit.

The setting is saved for the remote control currently in use.

Brightness

Adjusting brightness

Adjusting brightness of control display:

1. "Settings"
2. "Control display"
3. "Brightness"



4. Turn the controller until the desired brightness is obtained.
5. Press the controller.

The setting is saved for the remote control currently in use.

Depending on the lighting conditions, brightness control might not be immediately recognisable.

Lights

Vehicle Equipment

This chapter describes all standard, national and special equipment provided in the model series. Therefore equipment not available in a vehicle is also described, for example the selected special equipment or national version. That also applies to safety-relevant functions and systems.

Overview



- 1 Rear fog lights
- 2 Front fog lights
- 3 Automatic driving lights control/Adaptive Headlights/high-beam assistance/welcome light/daytime driving lights
- 4 Lights off/daytime driving lights
- 5 Side lights
- 6 Low-beam headlights / welcome light / high-beam assistance
- 7 Instrument lighting
- 8 Headlight beam throw adjustment

Side lights/low-beam headlights, driving lights control

General

Switch setting: 0,  ,  , 

If the driver's door is opened with the ignition switched off, the exterior lights are automatically switched off with these switch settings.

Side lights

Switch position  : the vehicle is illuminated all around, for example when parking.



You should not leave the side lights on for longer periods of time, since the battery could discharge and you might not have enough power to start the engine.

To park, it is better to switch on the one-sided parking light, see page 87.

Low-beam headlights

Switch position  with the ignition switched on: low-beam headlights are illuminated.

Welcome lights

On parking the vehicle, leave the switch in position  or  : the side lights and interior light illuminate briefly when unlocking the vehicle.

Activating/deactivating

1. "Settings"
2. "Lights"
3. "Welcome light"

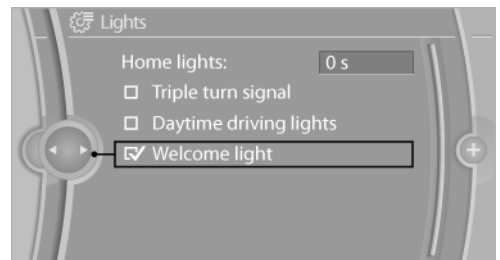

The setting is saved for the remote control currently in use.

Headlight courtesy delay feature

If the headlight flasher is activated after switching off the ignition, with the lights switched off, the low-beam headlights illuminate and remain on for a certain time.

Setting the duration

1. "Settings"
2. "Lights"
3. "Home lights: s"

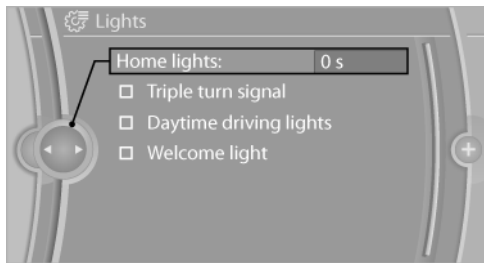

4. Set the duration.

The setting is saved for the remote control currently in use.

Automatic driving lights control

Switch position  : depending on ambient light conditions, the system switches the low-beam headlights off and on automatically, for example in a tunnel, at twilight and in rain or snow. The indicator light in the instrument cluster is illuminated.

The headlights may also come on when the sun is sitting low in a blue sky.

The low-beam headlights always remain on when the fog lights are switched on.

Personal responsibility

The driving lights control function is no substitute for your individual judgement of when it is necessary to switch on the lights.

The sensors are unable, for instance, to recognise fog or hazy weather. In such situations, switch on the lights manually to avoid any safety risk. ◀

Daytime driving lights

Halogen light: The daytime driving lights illuminate in position  .

xenon light: The daytime driving lights illuminate in position 0 or  .

Activating/deactivating

1. "Settings"
2. "Lights"
3. "Daytime driving lights"

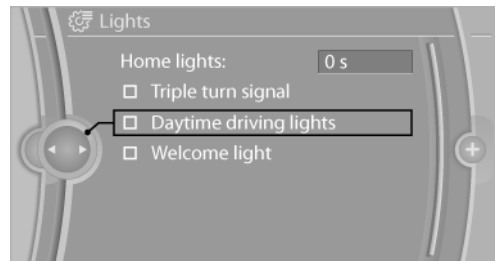

The setting is saved for the remote control currently in use.

Parking lights

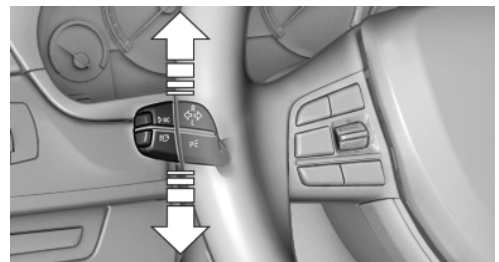

The vehicle can be illuminated on one side.

Switch on

With the ignition switched off, push the lever upwards or downwards beyond the resistance point for approximately 2 seconds.

Switching off

Press the lever briefly in the opposite direction as far as the resistance point.

Adaptive Headlights

Principle

Adaptive Headlights is a variable headlight control system that makes it possible to illuminate the road surface responsively.

The beams from the headlights follow the road ahead on the basis of the steering angle and other parameters.

Depending on the speed, the variable light distribution ensures even better illumination of the roadway.

The light distribution is automatically adapted to the speed. The city light is active as of a speed of less than 50 km/h, 30 mph. The motorway light is switched on at a speed higher than 110 km/h, 68 mph after approximately 30 seconds or as of a speed of 140 km/h, 87 mph.

Activating

Switch position  with the ignition switched on.

A cornering light is activated automatically depending on the steering angle or use of the turn indicators.

So as not to dazzle oncoming vehicles, the adaptive cornering light does not swivel to the driver's side when stationary.

When reversing, only the cornering light is active and illuminates the zone on the outside of the bend.

Adaptive Headlight beam throw adjustment

The adaptive headlight beam throw adjustment is a form of light distribution adapted to the course and shape of the road.

The light distribution is lowered on humps so that drivers of oncoming vehicles are not as distracted by glare, and raised in hollows for a longer visual range.

Malfunction

A Check Control message is displayed.

Adaptive Headlights are faulty or have failed. Have the system checked as soon as possible.

Headlight beam throw adjustment

With halogen headlights adjust the beam throw of the low-beam headlights manually in accordance with the vehicle load. Otherwise, the glare will disturb drivers of oncoming vehicles.

Values applicable when towing a trailer:

0 / 1 = 1 to 2 persons without luggage.

1 / 1 = 5 persons without luggage.

1 / 2 = 5 persons with luggage.

2 / 2 = 1 person, boot fully loaded.

High-beam assistance

Principle

When low-beam headlights are switched on, this system automatically switches the high-beam headlights on and off or fades out the areas which dazzle oncoming vehicles. This process is controlled by a sensor on the front of the interior mirror. The assistant ensures that the high-beam headlights are switched on whenever the traffic situation allows. You can also control the lights yourself at any time and switch them on and off as usual.

Activating

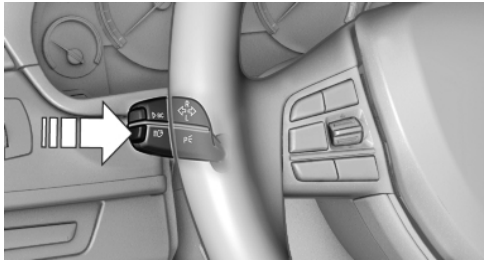

1. Turn the light switch to position or .
2. Press the button on the turn indicator lever, arrow.



The indicator light in the instrument cluster is illuminated.

When the lights are on, the beam is dipped and returned to full beam automatically.

The system responds to light from oncoming traffic and traffic driving ahead of you, and to adequate illumination, for example in built-up areas.

Raising and dipping manually

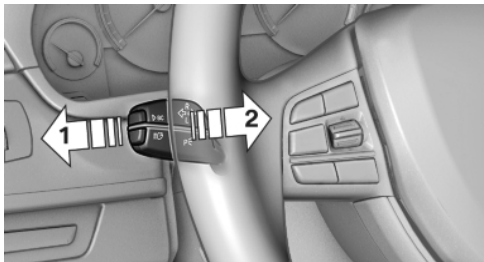

- ▷ High-beam headlights on, arrow 1.
- ▷ High-beam headlights off / headlight flasher, arrow 2.

The high beam assistance can be deactivated by manually raising and dipping. To reactivate high-beam assistance, press the button on the turn indicator lever.

System limits



Personal responsibility

The high-beam assistance cannot replace the personal decision to use the high beam. In such situations you should dip the headlights manually in order not to create a safety hazard. ◀

In the following situations, the system will not operate or its operation will be impaired and your intervention may be required:

- ▷ During extremely unfavourable weather conditions such as fog or heavy precipitation.
- ▷ When detecting poorly-lit road users such as pedestrians, cyclists or horseback riders or carts, and when trains or ships are close to the road, or when game are passing across the road.
- ▷ On narrow bends, steep uphill or downhill gradients, at traffic junctions or if your view of oncoming vehicles on a motorway is obstructed.
- ▷ In poorly-lit towns and where there are very reflective signs.
- ▷ At low road speeds.
- ▷ When the windscreen in front of the interior mirror is covered with condensation, dirt, stickers, labels, etc.

Camera

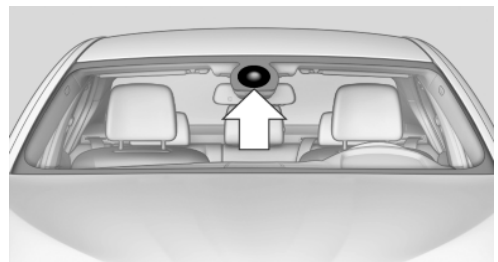

The camera is in the area of the base of the mirror.

Keep the windscreen clean and clear in the area in front of the rear view mirror.

Fog lights

Front fog lights

The side lights or low-beam headlights must be switched on.

 Press the button. The green indicator light is illuminated.

If automatic driving lights control, see page 87, has been activated, the low-beam headlights illuminate automatically when the front fog lights are switched on.

Guiding fog lights

In switch position , a guide fog light for a wider illumination is also activated up to a speed of 110 km/h, 68 mph.

Rear fog lights

The low-beam headlights or front fog lights must be switched on.

 Press the button. The yellow indicator light is illuminated.

Left-hand/right-hand traffic

Halogen headlights

Measures to prevent the headlights from dazzling oncoming vehicles are necessary if you take the vehicle into countries in which the opposite rule of the road applies. Your Service centre can provide the appropriate light benders that can be affixed to the headlight lenses. Proceed in accordance with the enclosed instructions when affixing the light benders to the headlights.

Xenon headlight

Light distribution of the headlights automatically avoids dazzling of the low-beam headlights when driving in a country in which the traffic drives on the opposite side.

Adaptive Headlights

When driving in a country where you drive on the opposite side of the road from the country the car is licensed, do not drive with the  setting, otherwise this could cause a dazzling effect from the cornering light.

Instrument lighting

Adjusting

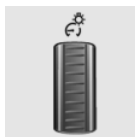

You can adjust the brightness of the instrument lighting only when the side lights or the low-beam headlights are switched on.

The lighting intensity can be set using the knurled wheel.

Interior light

General

The interior light, the footwell lights, door entry lighting and the courtesy lighting are controlled automatically.

The brightness of some equipment is influenced by the knurled wheel for the instrument lighting.



- 1 Interior light
- 2 Reading light

Switching the interior light on and off manually



Press the button.

To switch off permanently: press the button for approximately three seconds.

Switch on again: press button.

Reading lights



Press the button.

There are reading lights located at the front and in the rear beside the interior lights.

With the interior light switched off, the reading lights cannot be switched on.

Security

Vehicle Equipment

This chapter describes all standard, national and special equipment provided in the model series.

Therefore equipment not available in a vehicle is also described, for example the selected special equipment or national version. That also applies to safety-relevant functions and systems.

Airbags

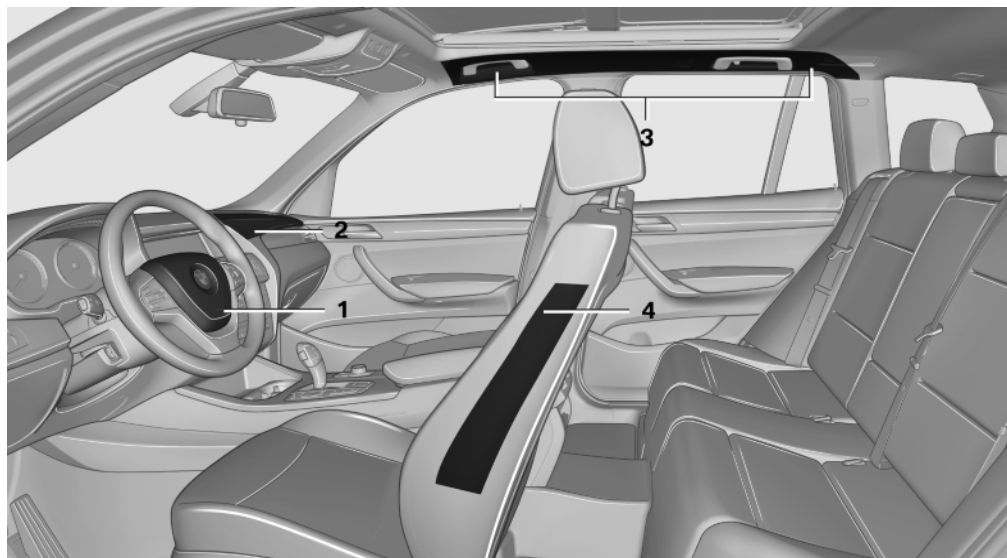

1 Front airbag, driver

2 Front airbag, front passenger

3 Head airbag

4 Side airbag

Front airbags

Front airbags protect the driver and front passenger in the event of a head-on collision where the action of the seat belts alone would be insufficient.

Side airbags

In a side-on crash, the side airbag supports the body from the side in the chest and pelvic area.

Head airbags

The head airbag supports the head in the event of a side-on collision.

Protective effect

Airbags are not activated by every collision, for example not in more minor accidents and rear-end collisions.



Information for optimal protective effect of the airbags

- ▷ Keep your distance from the airbags.
- ▷ Always grip the steering wheel on the rim, with your hands in the 3 o'clock and 9 o'clock positions, to minimise the risk of injury to the hands or arms in the event of the airbag being triggered.
- ▷ No other persons, pets or objects should be held or permitted to remain between the airbag and yourself.
- ▷ Do not use the front airbag cover on the front passenger's side as a tray.
- ▷ Keep the dashboard and windscreen in the area of the passenger's side free, i.e. do not attach adhesive foil or covers and do not fit brackets, for example for navigation devices or mobile phones.
- ▷ Make sure that the front passenger adopts a correct seated position, i.e. leaves his or her feet in the footwell and does not rest feet or legs on the instrument cluster, otherwise he/she could sustain leg injuries in the event of the front airbag being triggered.
- ▷ Do not fit seat covers, cushions or other objects not specifically approved for seats with integral side airbags to the front seats.
- ▷ Do not hang items of clothing such as coats or jackets over the backrests.
- ▷ Make sure that vehicle occupants keep their heads away from the side airbag and do not lean against the head airbag. Otherwise they could be injured should the airbags deploy.
- ▷ Do not dismantle the airbag system.
- ▷ Do not dismantle the steering wheel.
- ▷ Never attach any material to the airbag covers with adhesive; never place material over them or modify them in any way.
- ▷ Do not modify individual components of the system or its wiring in any way. This includes the covers on the steering wheel, instrument cluster, seats and roof posts as well as the sides of the roof lining. ◀

Even if all these instructions are complied with, depending on the circumstances in which an

accident occurs, certain injuries as a result of contact with the airbag cannot be entirely ruled out.

The noise caused by the deployment of an airbag may lead to brief and generally temporary hearing loss in vehicle occupants sensitive to noise.



In the event of faults, taking the airbags out of use and after they have been triggered

Avoid touching the system's components immediately after it has been triggered, as there is a risk of sustaining burns.

Only commission your Service Centre or authorised workshops with checking, repairing or dismantling and scrapping airbag generators, as your Service Centre or authorised workshops have the required legal permits for handling explosives.

Any careless or unskilled interference with the system could lead to its failure or to accidental triggering with the risk of injury. ◀

Functional readiness of the airbag system



When the ignition is switched on, the warning light in the instrument cluster briefly illuminates and so shows the functional readiness of the entire airbag system and the belt tensioner.

Airbag system disrupted

- ▷ Warning light does not illuminate after the ignition is switched on.
- ▷ Warning light is permanently illuminated.



Immediately check airbag system when there is a fault

Immediately check airbag system when there is a fault, otherwise you run the risk that the system does not function as expected in an accident in spite of corresponding seriousness of the accident. ◀

Not for Australia/New Zealand: Key switch for front passenger airbags

General

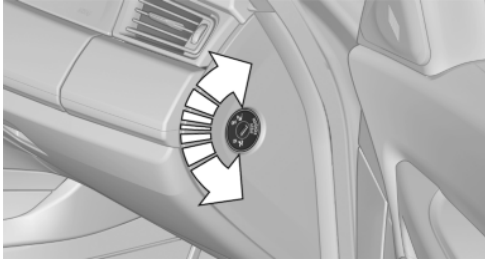

The front and side airbags for the front passenger can be deactivated and reactivated using the integrated key from the remote control.

Deactivating the front passenger airbags



Insert the key and press inwards where necessary.

While the key is pressed inwards, turn it to the OFF position as far as it will go. Once the stop position has been reached, remove the key.

The front passenger airbags are deactivated.
The driver's airbags remain active.

Key switch in end position

Make sure that the key switch is in the corresponding end position. Otherwise the airbags are not activated/deactivated. ◀

If a child restraint system is no longer fitted in the front passenger's seat, reactivate the front passenger airbags so that they are triggered as intended in the event of an accident.

The airbag condition is displayed on the check lamp on the headlining, see page 94.

Activating the front passenger airbags

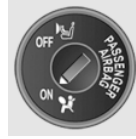

Insert the key and press inwards where necessary.

While the key is pressed inwards, turn it to the ON position as far as it will go. Once the stop position has been reached, remove the key.

Key switch in end position

Make sure that the key switch is in the corresponding end position. Otherwise the airbags are not activated/deactivated. ◀

The front passenger airbags are reactivated and can deploy correctly if the need arises.

Indicator light for front passenger airbags



The indicator light for the front passenger airbags shows the operating status of the front passenger airbags.

After switching on the ignition, the light indicates whether the airbags are activated or deactivated.



- ▶ When front passenger airbags are deactivated, the indicator light remains illuminated.
- ▶ When front passenger airbags are activated, the indicator light is not illuminated.

Runflat indicator RPA

Principle

The system does not measure the tyre pressures as such.

It detects a pressure loss on the basis of a comparison between the speeds at which the individual wheels rotate while the vehicle is in motion.

If a tyre loses pressure, its diameter changes. This in turn alters the rotational speed of the corresponding wheel. This is detected and reported as a flat tyre.

Operating requirements

The system must have been initialised with correct tyre inflation pressure, otherwise reliable signalling of a flat tyre cannot be assured. Each time the tyre pressure is adjusted or a tyre or wheel is changed, initialise the system again.

System limits



Sudden tyre damage

No warning can be given of extreme, sudden tyre failure caused by external factors. ◀

A natural, even loss of pressure in all four tyres that occurs over time is not detected. Consequently, check the tyre pressures at regular intervals.

In the following situations, the system could be slow to respond or operate incorrectly:

- ▶ If the system has not been initialised.
- ▶ When driving on snow-covered or slippery surfaces.
- ▶ When driving enthusiastically, causing the driven wheels to spin, high lateral acceleration.
- ▶ Driving with snow chains.

Status display

The current status of the runflat indicator can be shown on the control display, for example whether the runflat indicator is active.

1. "Vehicle information"
2. "Vehicle status"
3.  "Flat Tyre Monitor"

The status is displayed.

Initialising

On initialisation, the current tyre pressures are stored as a reference for detection of a flat tyre. The initialisation is started by confirming the correct inflation pressures.

When driving with snow chains fitted, do not initialise the system.

1. "Vehicle information"
2. "Vehicle status"
3.  "Confirm tyre pressure"
4. Start the engine – do not drive off.
5. Start the initialisation with "Initialise tyre pressure".
6. Drive off.

Initialising is completed while the vehicle is in motion; this process can be interrupted at any time.

Initialising resumes automatically when you continue your journey.

Indication of a flat tyre



The yellow warning light is illuminated. A Check Control message is displayed.

There is a flat tyre or substantial loss of tyre pressure.

1. Reduce your speed and cautiously stop the car. Avoid violent or sudden braking and steering manoeuvres.
2. Check whether the vehicle is equipped with standard tyres or run-flat tyres.

The symbol identifying run-flat tyres, see page 249, is the circle with the letters RSC on the tyre sidewall.

 Do not continue a journey without run-flat tyres

Do not continue your journey if the vehicle is not equipped with run-flat tyres, otherwise a serious accident could occur. ◀

It is possible that Dynamic Stability Control DSC is activated as soon as the message for a puncture appears.

What to do in the event of a flat tyre

Standard tyres

1. Identify the damaged tyre.

Do this by checking the air pressure in all four tyres.

The tyre inflation pressure display of the Mobility System, see page 250, can be used for this.

If all four tyres are inflated to the correct pressures, the runflat indicator might not have been initialised. In this case initialise the system.

If it is not possible to identify, contact a Service centre.

2. Fix the puncture with the Mobility System, see page 250.

Run-flat tyres

Maximum speed

If a tyre has punctured you can continue your journey, driving at speeds up to a maximum of 80 km/h, 50 mph.

Continuing a journey with a flat tyre

If you continue a journey with a flat tyre:

1. Avoid violent or sudden braking and steering manoeuvres.

2. Do not exceed a speed of 80 km/h, 50 mph any longer.
3. As soon as you get an opportunity, check the tyre pressure in all four tyres.

If all four tyres are inflated to the correct pressures, the runflat indicator might not have been initialised. In this case initialise the system.

Maximum possible distance with tyres entirely deflated:

The possible distance with a flat tyre depends on the load and strain on the vehicle during the journey.

With a moderate vehicle load, the possible distance travelled is approx. 80 km, 50 miles.

When driving with damaged tyres, the vehicle handling changes, for example quicker loss of traction when braking, longer stopping distance and modified self-steering behaviour. Adapt driving style accordingly. Avoid abrupt steering or driving over obstacles, for example curbs, potholes etc.

As the possible distance largely depends on the strain on the vehicle during the journey, this can be shorter, or longer if the vehicle is driven carefully, according to speed, road condition, outside temperature, load etc.

 Continuing a journey with a flat tyre
Drive moderately and do not exceed a speed of 80 km/h, 50 mph.

If tyre pressure has fallen, vehicle handling changes, for example reduced directional stability when braking, longer stopping distance and modified self-steering behaviour. ◀

 Continuing a journey with a flat tyre and trailer

When a trailer is being towed, heavy trailers in particular can start to snake. For this reason, do not exceed 60 km/h, 35 mph, as otherwise there is a danger that accidents might occur. ◀



Final tyre failure

Vibration or loud noises while driving may be an indication that the tyre has finally failed. Reduce your speed and stop, otherwise sections of the tyre could become detached and cause an accident. Do not drive the car any further; contact your Service Centre instead. ◀

Lane departure warning

Principle

This system warns if the vehicle leaves the lane, when the vehicle is on roads with lane markings and travelling above a given speed. Depending on the equipment for your country, this speed is between 55 km/h, approximately 35 mph and 70 km/h, approximately 45 mph. When this system is switched on below this speed, a message is displayed in the instrument cluster.

When there are warnings, the steering wheel starts to vibrate slightly. The time of this warning may vary depending on the current driving situation.

The system does not issue a warning if the driver indicates before leaving the driving lane.

Switching on/off



Press the button.

- ▷ On: LED is illuminated.
- ▷ Off: LED turns off.

The status is saved for the remote control currently in use.

Display

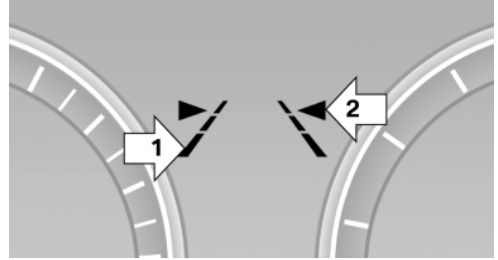

- ▷ Lines, arrow 1: the system is activated.
- ▷ Arrows, arrow 2: at least one lane boundary line has been detected and warnings can be issued.

Output of the warning

If the vehicle leaves the driving lane and a lane boundary line is detected, the steering wheel starts to vibrate.

If the turn indicator is set before changing lanes, no warning is issued.

Cancellation of the warning

The warning is cancelled:

- ▷ Automatically after approximately three seconds.
- ▷ On returning to the correct lane.
- ▷ With strong braking.
- ▷ On indicating.

System limits



Personal responsibility

The system is no substitute for your personal assessment of the road ahead and the traffic situation.

If a warning is issued, do not move the steering wheel in an unnecessarily violent manner, as otherwise you could lose control of the vehicle. ◀

The function can be restricted, for example in the following situations:

- ▷ In thick fog and heavy rain or snow.

- ▷ With worn, poorly visible, merging/separating or ambiguous boundary lines, for example in areas where there are road works.
- ▷ If boundary lines are covered by snow, ice, dirt or water.
- ▷ On sharp bends or narrow roads.
- ▷ If the boundary lines are not white.
- ▷ If boundary lines are obscured.
- ▷ If the vehicle is moving too close to the vehicle ahead.
- ▷ With bright light from oncoming traffic.
- ▷ When the windscreen in front of the interior mirror is covered with condensation, dirt, stickers, labels, etc.
- ▷ During the calibration process of the camera immediately after the vehicle is supplied.

Camera

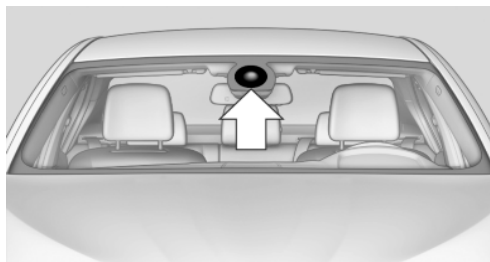

The camera is in the area of the base of the mirror.

Keep the windscreen clean and clear in the area in front of the rear view mirror.

Dynamic brake lights

Principle



- ▷ Normal braking: brake lights illuminate.
- ▷ Severe braking: brake lights flash.

Shortly before the vehicle comes to a standstill, the hazard warning system is activated.

Deactivating the hazard warning system:

- ▷ Press the accelerator.
- ▷ Press the hazard warning system button.

Driving stability control systems

Vehicle Equipment

This chapter describes all standard, national and special equipment provided in the model series. Therefore equipment not available in a vehicle is also described, for example the selected special equipment or national version. That also applies to safety-relevant functions and systems.

Anti-lock Brake System, ABS

ABS prevents the wheels from locking when the brakes are applied.

Steering control is retained even in the event of full braking, enhancing active road safety.

ABS is ready to operate each time the engine is started.

Brake assist

When the brake is pressed quickly, this system automatically applies maximum braking power assistance. With full braking, this keeps the braking distance as short as possible. It also makes full use of the advantages offered by ABS.

Maintain pressure on the brake during the entire brake application.

Dynamic Stability Control, DSC

Principle

DSC prevents the driven wheels losing traction when you pull away from rest or accelerate.

DSC is also able to detect unstable driving conditions such as loss of traction at the rear or vehicle slip over the front wheels. DSC reduces engine output and applies the brakes at individ-

ual wheels, helping, within the limits imposed by the laws of physics, to keep the car safely on course.



Adapting driving style to the prevailing conditions

It is therefore the driver's responsibility to adopt a suitable driving style in every situation.

Not even DSC can overcome the laws of physics.

Do not limit the additional safety afforded by this system by taking driving risks. ◀

Indicator and warning lights



If indicator light is flashing: DSC is regulating the acceleration and braking forces.

If indicator light is illuminated: DSC has failed.

Deactivate DSC: DSC OFF

Driving stability during acceleration and cornering is restricted if DSC is deactivated.

To support the driving stability, activate DSC as soon as possible.

Deactivate DSC



Press and hold down the button – but for no longer than approx. 10 seconds – until the DSC OFF indicator light in the instrument cluster is illuminated and DSC OFF is displayed.

The DSC system is switched off.

Activate DSC



Press the button. The DSC OFF and DSC OFF indicator lights are not illuminated.

Indicator and warning lights

DSC OFF is displayed in the instrument cluster when DSC is deactivated.



If indicator light is illuminated: DSC is deactivated.

Dynamic Traction Control, DTC

Principle

The DTC system is a variant of the DSC optimised for forward momentum.

In particular road conditions, for example roads on which snow has not been cleared, the system ensures maximum forward momentum but limited driving stability.

Therefore, drive with the appropriate caution.

In the following exceptional situations it may be best to activate DTC for a short time:

- ▷ When driving in slush or on uncleared, snow-covered roads.
- ▷ If the car has to be rocked out of or started in deep snow or on a loose surface.
- ▷ Driving with snow chains.

Deactivating/activating Dynamic Traction Control, DTC

With activated Dynamic Traction Control, DTC you have maximum traction on loose surfaces. Driving stability is limited on accelerating and cornering.

Activating DTC



Press the button.

TRACTION is displayed in the instrument cluster and the DSC OFF indicator light is illuminated.

Deactivating DTC



Press the button again.

TRACTION and the DSC OFF indicator light are not illuminated.

Performance Control

Performance Control increases the agility of your vehicle.

To increase agility, when the driving style is sufficiently sporty, the rear wheel on the inside of the curve is braked and the resulting braking power is simultaneously largely compensated by an engine intervention.

xDrive

xDrive is the four-wheel drive system available in your vehicle. The combination of xDrive and DSC further optimises traction and driving dynamics. The xDrive four-wheel drive system distributes the acceleration forces variably to the front and rear axles based on the driving situation and the condition of the road.

Hill Descent Control HDC

Principle

The Hill Descent Control function automatically regulates the speed when driving along steep inclines. The vehicle moves at a speed approximately more than walking speed, without the driver braking.

HDC can be activated under approximately 35 km/h, approximately 22 mph. When driving downhill, the vehicle reduces the speed to approx. walking speed and holds this as the constant speed.

While the brakes are pressed manually, the system switches to standby. As a result, system braking does not take place.

Only use HDC in low gears or in gear position D or R.

Increasing or reducing speed

Using the rocker switch for Cruise Control on the steering wheel, set a speed of between approximately 6 km/h, 4 mph to approximately 25 km/h, 15 mph. The speed of the vehicle can be changed by slightly pressing on the gas.

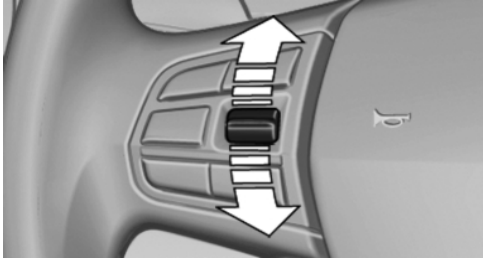

- ▶ Press the rocker switch upwards until the resistance point is reached: the speed is increased in increments.
- ▶ Press the rocker switch upwards beyond the resistance point: the speed continues to increase as long as the rocker switch is pressed.
- ▶ Press the rocker switch downwards until the resistance point is reached: the speed is decreased in increments.
- ▶ Press the rocker switch downwards until the resistance point is reached: when driving forwards, the speed is reduced to approximately 10 km/h, 6 mph. When driving backwards, it is reduced to approximately 6 km/h, 4 mph.

Activating HDC



-  Press the button. The LED above the button is illuminated.

Deactivating HDC

-  Press the button again. The LED turns off. HDC is automatically deactivated at speeds above approximately 60 km/h, 37 mph.

Display in the instrument cluster



The speedometer shows the selected set speed.

- ▶ Green: the system brakes the vehicle.
- ▶ Orange: system in standby.

Malfunction

A message will appear on the instrument cluster. HDC is not available, for example due to a high brake temperature.

Dynamic Damper Control

Principle

The system reduces unwanted vehicle movements when a dynamic driving style is used or on uneven roads.

Depending on the condition of the road and the driving style, this enhances driving dynamics and driving comfort.

Programs

The system provides two different programs.

The programs can be selected via the Drive experience, see page 102.

SPORT

Resolute sports regulation of the shock absorbers for greater agility when driving.

SPORT+

Resolute sports regulation of the shock absorbers for greater agility when driving, with restricted driving stability.

COMFORT

Balanced vehicle control.

Variable sports steering

The variable sports steering amplifies the steering angle of the front wheels when the steering wheel is fully turned, for example in tight bends or when parking. The steering becomes more direct.

It also varies the force required when steering, depending on the speed.



This enables a sports-oriented steering response. In addition, steering is made easier during parking and manoeuvring.

Drive experience switch

Principle

With the drive experience switch, certain properties of the vehicle can be adjusted. Various programs can be selected for this. Using the drive experience button and using the DSC OFF button, one program can be activated in each case.

Operation of the programs

Press the button	Program
	DSC OFF TRACTION
	SPORT+ SPORT COMFORT ECO PRO

Automatic program change

In the following situations, there is an automatic switch to COMFORT:

- ▷ Failure of the Dynamic Damper Control.
- ▷ Failure of the Dynamic Stability Control DSC.
- ▷ In the event of a flat tyre.
- ▷ Activating cruise control in TRACTION or DSC OFF mode.

DSC OFF

When you select DSC OFF, see page 99, driving stability during acceleration and cornering is restricted.

TRACTION

With TRACTION you have maximum traction on loose surfaces. Dynamic, see page 100, Traction Control, DTC, is activated. Driving stability is limited on accelerating and cornering.

SPORT+

Sporty driving with optimised chassis with restricted driving stability.

Driver assumes part of the task of stabilising the vehicle.

Activating SPORT+



Press the button repeatedly until SPORT+ is displayed in the instrument

cluster and the DSC OFF indicator light is illuminated.

Automatic program change

When activating the cruise control, the SPORT mode is automatically selected.

Indicator and warning lights

SPORT+ is displayed in the instrument cluster.



DSC OFF indicator light illuminates.

SPORT

Sporty driving with optimised chassis with maximum driving stability.

The program can be configured individually. The configuration is saved for the remote control currently in use.

Activating SPORT



Press button until SPORT is displayed in the instrument cluster.

Configuring SPORT

If the display is activated on the control display, see page 104, the Sport program can be set to individual requirements.

- ▶ Activating the Sport program.
- ▶ "Configure SPORT"
- ▶ Configure the program.

The Sport program can also be configured before it is activated:

1. "Settings"

2. "SPORT mode"

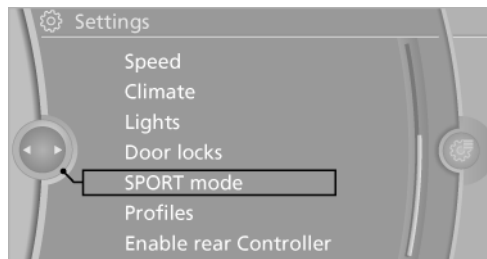

3. Configure the program.

This configuration is called up when the Sport program is activated.

COMFORT

For a balanced configuration with maximum driving stability.

Activate COMFORT



Press button until COMFORT is displayed in the instrument cluster.

In certain situations, there is an automatic switch into the COMFORT program, automatic program change, see page 102.

ECO PRO

ECO PRO, see page 149, provides consistent fuel consumption-reducing adjustment for maximum range at maximum driving stability.

Comfort functions and the engine control can be adjusted.

The program can be configured individually.

Activate ECO PRO



Press the button until ECO PRO is displayed in the instrument cluster.

Configure ECO PRO

1. Activate ECO PRO.
2. "Configure ECO PRO"

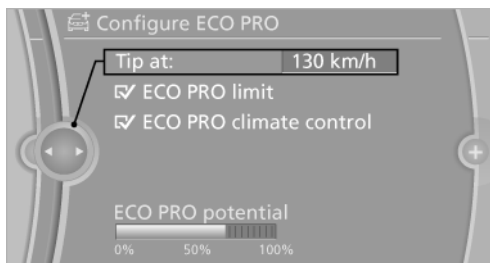

Make the desired settings.

Displays

Program selection

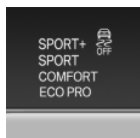

On pushing the button, a list of programs that can be selected is displayed.

Selected program

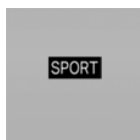

The selected program is shown in the instrument cluster.

Display on the control display

Program changes can be displayed on the control display.

1. "Settings"
2. "Control display"

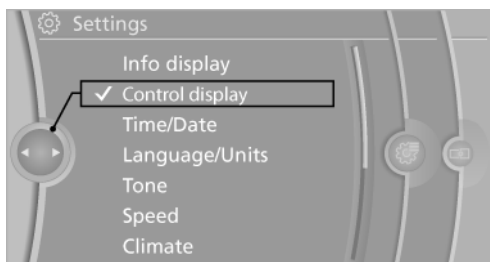

3. "Driving mode info"

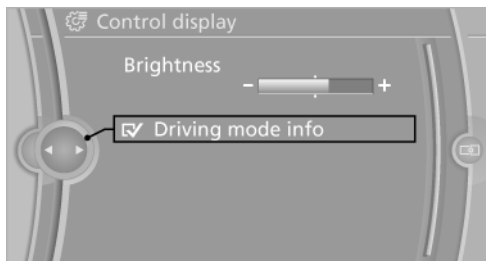

Driving comfort

Vehicle Equipment

This chapter describes all standard, national and special equipment provided in the model series. Therefore equipment not available in a vehicle is also described, for example the selected special equipment or national version. That also applies to safety-relevant functions and systems.

Forward alert

Principle

The system warns as of approximately 15 km/h, 10 mph in two stages that there might be a danger of collision. The time of these warnings may vary depending on the current driving situation.

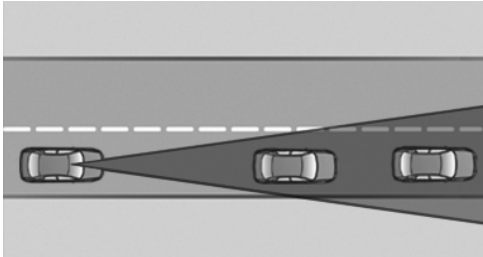

This considers vehicles in a similar direction of movement if they are in the detection range of the system.

When deliberately approaching a vehicle, the collision warning is activated later to avoid disruptive warnings.

Warning levels

Advance warning

Warning, for example if a danger of collision is anticipated or there is a very short distance to a vehicle ahead.

Acute warning

Warning in the event of an immediate collision if the vehicle approaches another vehicle with relatively high differential speed.

Switching the warning function on/off



 Press the button.

- ▷ On: LED is illuminated.
- ▷ Off: LED turns off.

The status is saved for the remote control currently in use.

Configure warning time

After the warning function is switched on, the warning time can be set using iDrive.

The selected warning time is saved for the remote control currently in use.

Display in the instrument cluster

The forward alert can be output in the instrument cluster, the Head-Up Display and acoustically.

Warning levels

Symbol Measure



Vehicle illuminates red: advance warning

Increase distance



Vehicle flashes red and an acoustic signal sounds: acute warning

System indicates that you must brake and/or manoeuvre the vehicle yourself.



Adapting speed and driving style

The display does not release you from your responsibility to adapt your speed and driving style to prevailing driving conditions. ◀

System limits



Your own attentiveness

System limitations mean that it can occur that warnings are not issued, are issued too late, or are issued incorrectly. This means that you must pay full attention so that you are able to intervene actively at any time. Otherwise there is the risk of an accident. ◀

Detection range

The detection capabilities of the camera and the forward alert are limited.

This is why it can occur that no warnings are issued or they are issued late.

It is possible that the following are not detected:

- ▷ Slow-moving vehicle when approaching at high speed.
- ▷ Vehicles suddenly cutting in or decelerating heavily.
- ▷ Vehicles with unusual rear view.
- ▷ Two-wheeled vehicles ahead.

Restrictions of the function

The function can be restricted, for example in the following situations:

- ▷ In thick fog, rain, spray or snowfall.
- ▷ On sharp bends.
- ▷ If the field of view of the camera and/or the windscreen is dirty or covered.
- ▷ With bright light from oncoming traffic.
- ▷ For vehicles without sufficiently visible rear lights.
- ▷ For partially covered vehicles.
- ▷ Up to 10 seconds after starting the engine using the start/stop button.
- ▷ During the calibration process of the camera immediately after the vehicle is supplied.

Sensitivity of the advance warning

After every adjustment of the advance warning time, false warnings can increasingly occur.

Camera

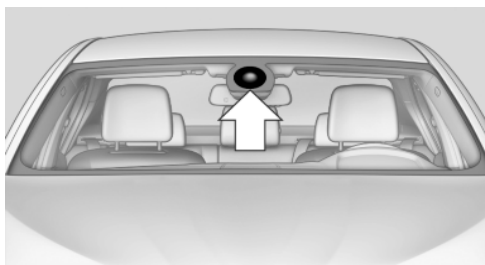

The camera is in the area of the base of the mirror.

Keep the windscreen clean and clear in the area in front of the rear view mirror.

Cruise Control

Principle

The system is operational as of approximately 30 km/h, 20 mph.

The speed set using the control elements on the steering wheel is maintained.

On downhill gradients, the system will brake the car if the braking action of the engine alone is insufficient.

Unfavourable conditions

Do not use the system if unfavourable conditions do not permit driving at constant speed, for example:

- ▷ On stretches with a great many corners and bends.
- ▷ In heavy traffic.
- ▷ If the road is icy, if there is fog, snow, rain or a loose road surface.

Otherwise you could lose control of the car and cause an accident as a result. ◀

Controls

Overview

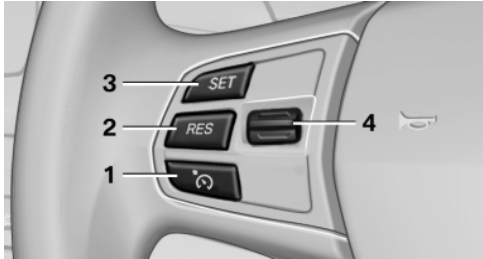

- 1 System on/off, interrupt
- 2 Resume speed
- 3 Set speed
- 4 Maintaining/setting, changing the current speed

Switch on



Press the button on the steering wheel.

The speedometer marker is set to the current speed.

Cruise Control can be used.

Switch off



Disabled or interrupted system

When the system is disabled or interrupted, intervene actively by braking and manoeuvring the vehicle yourself, as otherwise there is a danger that accidents might occur. ◀



Press the button.

- ▷ When activated: press twice.
- ▷ When interrupted: press once.

The indicators extinguish. The saved desired speed is deleted.

Interrupting



When the system is activated, press the button.

The system interrupts automatically if:

- ▷ The brake is applied.
- ▷ The clutch is applied.
- ▷ The transmission is moved from position D.
- ▷ Dynamic Traction Control, DTC is activated or DSC is disabled.
- ▷ DSC intervenes.
- ▷ HDC is activated.

Maintaining and saving the current speed



Press the button.

Or

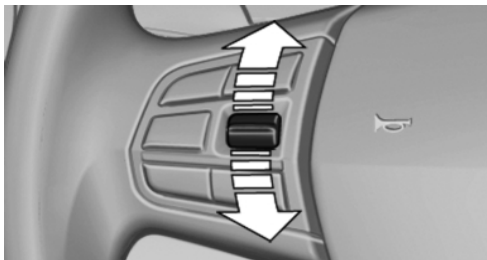

During the interruption, press the rocker switch.

With the system switched on, the driven speed is maintained and saved as the desired speed.

It is displayed in the speedometer and briefly in the instrument cluster, displays in the speedometer, see page 108.

When maintaining or saving the cruise control, the Dynamic Stability Control DSC will be switched on if required.

Changing/maintaining speed

By pressing the rocker switch without interruption, the current driven speed can also be maintained and saved.

Adapting the desired speed

Adapt the desired speed to the traffic conditions and always be prepared to apply brakes, as otherwise there is a danger that accidents might occur. ◀

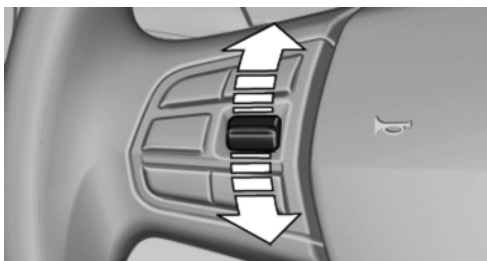

Press the rocker switch repeatedly upwards or downwards until the desired speed is set.

With the system active, the speed that is then shown is set and will be achieved on a clear road.

- ▷ Each time the rocker switch is pressed lightly towards the resistance point, the desired speed is increased or decreased by approximately 1 km/h, 1 mph.
- ▷ Each time the rocker switch is pressed beyond the resistance point, the desired speed is increased or decreased to the next multiple of 10 km/h on the speedometer display.
- ▷ Pressing the rocker switch until the resistance point is reached and holding accelerates or slows down the vehicle without pressing the accelerator. The speed is maintained after letting go of the rocker switch. Pressing beyond the resistance point results in greater vehicle acceleration.

Calling up the desired speed

 Press the button.



The saved speed is regained and maintained.

Displays in the instrument cluster

Indicator lamp

 Depending on the equipment the indicator light in the instrument cluster shows whether the system is switched on.

Desired speed

- ▷  Marker illuminates green: the system is active.
- ▷  Marker illuminates orange: the system is interrupted.
- ▷  Marker does not illuminate: the system is inactive.

Brief status display

 Selected desired speed.

If the symbol appears in the display for Check Control messages, it is possible that the conditions for operation may have not been met.

Park Distance Control, PDC

Principle

In addition to the Park Distance Control, PDC, the rear-view camera, see page 111, can be activated.

PDC assists you with parking. Slowly approaching an object in front of or behind your vehicle is signalled by means of:

- ▷ Audible warning signals.
- ▷ Visual display.

Measurement

Ultrasonic sensors in each bumper measure the distance.

The range is approximately 2 m, 6 ft.

An acoustic warning is only issued:

- ▷ From the front sensors and the two rear corner sensors at approximately 60 cm, 24 in.
- ▷ For the centre rear sensors at approximately 1.50 m, 5 ft.

System limits



Also monitor the traffic situation

PDC is no substitute for your personal assessment of the traffic situation. Also monitor the traffic situation around the vehicle by observing it directly. Otherwise, there is a danger that accidents might occur due to other road users or objects located outside of detection range of the PDC, for example.

Loud sound sources outside or inside the car can drown out the PDC signal. ◀



Avoid driving fast with PDC active

Avoid approaching an object at speed.

Avoid moving off at speed while PDC is not yet active.

Due to physical conditions the system could warn when it is too late. ◀

Limits of the ultrasound measurement

Detection of objects might not be possible if the physical limits of the ultrasonic measuring principle are exceeded, for instance by:

- ▷ Trailer noses and hitches.
- ▷ Thin or wedge-shaped objects.
- ▷ Low objects.
- ▷ Objects with corners and sharp edges.

Low objects already indicated, such as kerbs, may enter the sensors' blind areas before or after a continuous audible signal is given.

Higher, protruding objects such as ledges may not be detectable.

False alarms

Under the following conditions, PDC can issue a warning although there is no obstacle in the detection range:

- ▷ In heavy rain.
- ▷ If the sensors are very dirty or covered with ice.
- ▷ If the sensors are covered with snow.
- ▷ On rough road surfaces.
- ▷ In large, rectangular buildings with smooth walls, for example underground car parks.
- ▷ Due to dense exhaust gas.
- ▷ Due to other ultrasonic sources, for example sweeping machines, steam-jet cleaners or neon lights.
- ▷ If the cover of the trailer tow hitch is incorrectly seated.

Towing a trailer

The rear sensors are unable to perform any meaningful measurements. They therefore do not switch on.

A Check Control message is displayed.

Automatic activation

While the engine is running, engage transmission position R.

Automatic switching off when moving forwards

The system switches off when a certain distance or speed is exceeded.

Switch the system back on if necessary.

Switching on/off manually



 Press the button.

- ▷ On: LED is illuminated.
- ▷ Off: LED turns off.

Audible warning signals

An intermittent sound indicates the position of an object as the car approaches it. For instance, if an object is identified to the rear left of the car, the warning signal sounds from the rear left loudspeaker.

The shorter the distance to an object becomes, the shorter the intervals become.

If the distance to a detected object is less than approximately 30 cm, 12 in, a continuous tone sounds.

If there are objects in front of and behind the vehicle, an alternating continuous tone sounds.

An intermittent continuous tone is interrupted after approximately three seconds:

- ▷ If you remain in front of an object that was detected by only one of the corner sensors.

- ▷ If you are driving parallel to a wall.

The sound signal is switched off:

- ▷ Once the vehicle has moved more than approximately 10 cm, 4 in away from an object.
- ▷ If gearbox position P is engaged.

Volume control

You can set the volume of the PDC sound signal, see page 175.

The setting is saved for the remote control currently in use.

Visual warning

When the vehicle is approaching an object it will be shown on the control display. Objects that are further away from the car will appear on the control display before an audible warning signal is given.

A display is superimposed as soon as PDC is activated.

If the image from the rear-view camera was last selected, this is displayed again. To switch over to PDC:

1.  "Rear view camera" Select the symbol on the control display.
2. Press the controller.

The setting is saved for the remote control currently in use.

Zoom image

In the left part of the screen the vehicle is shown enlarged.

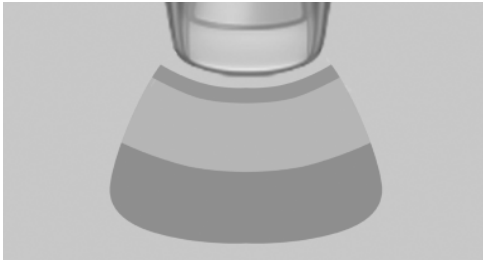

- ▷ Forward gear engaged or transmission position D selected: front vehicle area.
- ▷ Reverse gear engaged or transmission position R selected: rear vehicle area.

Malfunction

A Check Control message, see page 73, is displayed in the instrument cluster.

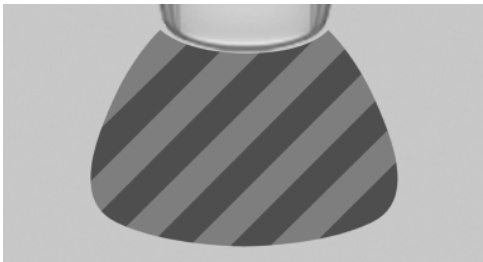

The areas in front of and behind the vehicle are shown as shaded on the control display. PDC has failed. Have the system checked.

To ensure correct functionality:

- ▷ Keep sensors clean and free from ice.
- ▷ Do not spray the sensors with high-pressure cleaners for an extended period of time and maintain a distance of at least 30 cm, 12 in.

Rear-view camera

Principle

The rear-view camera offers assistance when reversing into a parking space or manoeuvring. To achieve this, the area behind the vehicle is displayed on the control display.

System limits



Also monitor the traffic situation

Also monitor the traffic situation around the vehicle by observing it directly. Otherwise, there is a danger that accidents might occur due to other road users or objects located outside of the screen area of the rear-view camera, for example. ◀



Detection of objects

Higher, protruding objects such as ledges may not be detectable by the rear-view camera. ◀

Automatic activation

While the engine is running, engage transmission position R.

The image from the rear-view camera is displayed if the system was switched on using the iDrive.

Automatic switching off when moving forwards

The system switches off when a certain distance or speed is exceeded.

Switch the system back on if necessary.

Switching on/off manually



Press the button.

- ▷ On: LED is illuminated.
- ▷ Off: LED turns off.

PDC is displayed on the control display.

Switching on the rear-view camera via iDrive, see page 113.

Assistance functions

Operating requirements

- ▷ The rear-view camera is switched on.
- ▷ The tailgate is completely closed.

Driving lane lines

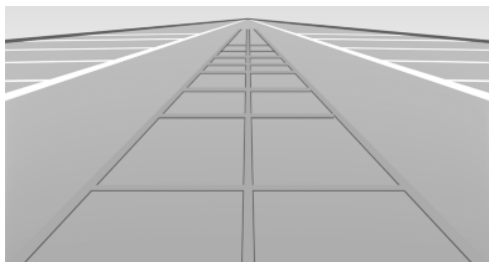

- ▷ These can appear in the image from the rear-view camera in transmission position R.
- ▷ They help to estimate the required space when parking and manoeuvring on a level road surface.
- ▷ They are dependent on the current steering angle and are continuously adapted to steering wheel movements.

Displaying parking assistance lines, see page 113.

Turning circle lines

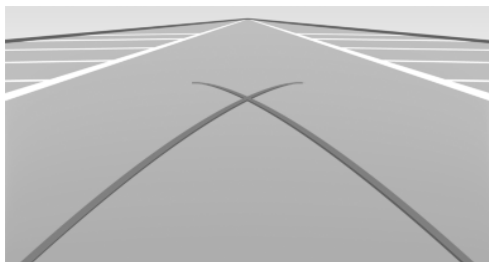

- ▷ They can appear in the image from the rear-view camera.

- ▷ They show the course of the smallest possible turning circle on a level road surface.
- ▷ When the steering wheel is fully turned, only a turning circle line is displayed.

Displaying parking assistance lines, see page 113.

Parking with the help of driving lane and turning circle lines

1. Position the vehicle so that the turning circle lines are on the limit of the parking space.

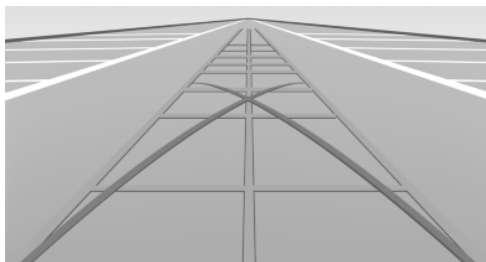

2. Turn the steering wheel so that the driving lane line covers the corresponding turning circle line.

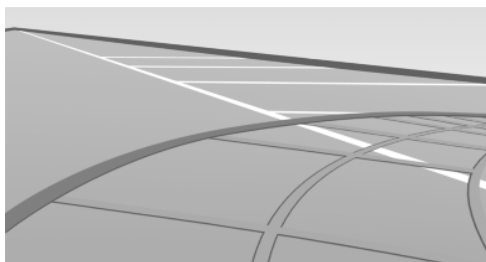

Obstacle marking

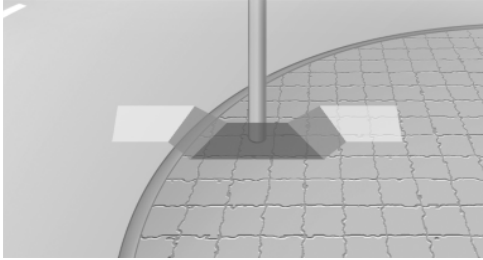

- ▶ Spaced markings can appear in the image from the rear-view camera.

Its colour incrementation corresponds to the markings of PDC. It is easier to estimate the distance to the displayed object.

Zoom to trailer tow hitch

To facilitate connecting up a trailer, the picture area around the trailer tow hitch can be zoomed.



The distance between the trailer and the trailer tow hitch can be estimated with the aid of two static semicircles.

A docking-on line dependent on the steering angle helps you to aim at the trailer with your trailer tow hitch.

The zoom function can be enabled when the camera is switched on.

Displaying the trailer tow hitch via iDrive, see page 113.

Activating assistance functions

A number of assistance functions can be active simultaneously.

The zoom function for towing a trailer can only be activated individually.

Displaying parking assistance lines

 "Parking help lines"

Driving lane and turning circle lines are displayed.

Displaying obstacle marking

 "Obstacle marking"

Spatially shaped markings are displayed.

Displaying the trailer tow hitch

 "Trailer tow bar - zoom"

The zoom to the trailer tow hitch is displayed.

Display on the control display

Switching on the rear-view camera via iDrive

With PDC activated:

 "Rear view camera"

The image from the rear-view camera is displayed. The setting is saved for the remote control currently in use.

Brightness

With rear-view camera switched on:

1.  Select the symbol.
2. Turn the controller until the desired setting is reached and press the controller.

Contrast

With rear-view camera switched on:

1.  Select the symbol.
2. Turn the controller until the desired setting is reached and press the controller.

Camera

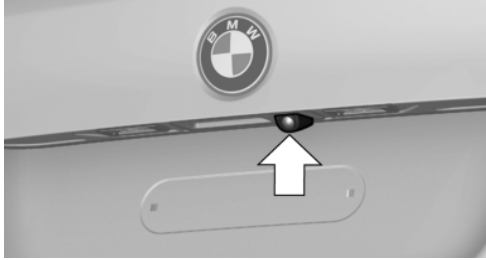

The lens of the camera is located in the handle strip of the tailgate. Dirt can impair the quality of the picture.

Clean the lens, see page 280.

Top View

Principle

Top View assists you with manoeuvring and parking. To achieve this, the area around the door and road is displayed on the control display.

Detection

The two cameras in the exterior mirrors and the rear-view camera are used to view the area around the car.

The range at the sides and rear is approx. 2 m, approx. 7 ft.

In this way, obstacles up to the height of the exterior mirror are detected early.

System limits

Top View cannot be used in the following situations:

- ▷ With a door open.
- ▷ With the tailgate open.
- ▷ With an exterior mirror folded in.
- ▷ In poor light conditions.

In some of these situations a Check Control message is displayed.



Also monitor the traffic situation

Also monitor the traffic situation around the vehicle by observing it directly. Otherwise, there is a danger that accidents might occur due to other road users or objects located outside of the screen area of the cameras, for example. ◀

Automatic activation

While the engine is running, engage transmission position R.

The images from Top View and PDC are displayed if the system was switched on using the iDrive.

Automatic switching off when moving forwards

The system switches off when a certain distance or speed is exceeded.

Switch the system back on if necessary.

Switching on/off manually



Press the button.

- ▷ On: LED is illuminated.
- ▷ Off: LED turns off.

If Top View is displayed, switch on the rear-view camera via iDrive, see page 115.

Visual warning

When the vehicle is approaching an object it will be shown on the control display.

If there is a short distance to an object at the front, a red bar in front of the vehicle is displayed in the same way as for the PDC display.

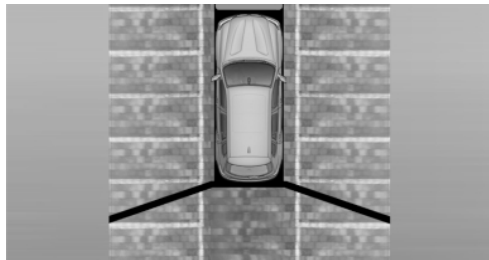

The display appears as soon as Top View is activated.

If the image from the rear-view camera was last selected, this is displayed again. To switch over to Top View:

 "Rear view camera" Select the symbol on the control display.

The setting is saved for the remote control currently in use.

Display on the control display

Switching on the rear-view camera via iDrive

With Top View switched on:

 "Rear view camera"

The image from the rear-view camera is displayed. The setting is saved for the remote control currently in use.

Brightness

With Top View switched on:

-  "Brightness"
- Turn the controller until the desired setting is reached and press the controller.

Contrast

With Top View switched on:

-  "Contrast"

- Turn the controller until the desired setting is reached and press the controller.

Displaying the turning circle and driving lane line

- The static red turning circle line indicates the space requirement to the side with full steering angle.
- The variable green driving lane line helps to estimate the actual space requirement to the side.

The driving lane line depends on the current steering angle and is continuously adapted to steering wheel movements.

"Parking help lines"

The turning circle and driving lane lines are displayed.

Cameras

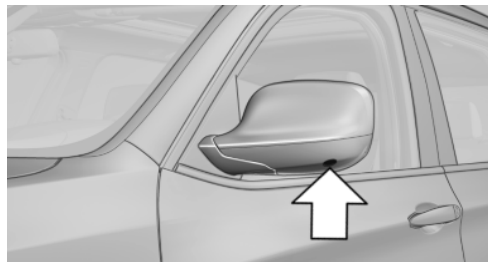

The lenses of the Top View cameras are located in the base of the exterior mirror housings. Dirt can impair the quality of the picture.

Clean the lens, see page 280.

Head-Up Display

Principle

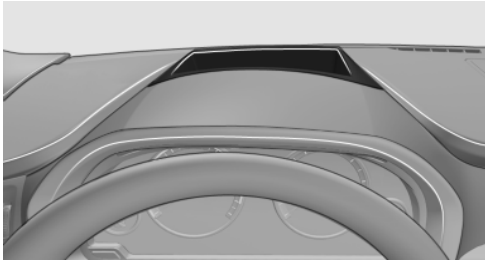

The system projects important information into the field of vision of the driver, for example speed.

This enables the driver to register this information without having to divert attention from the road.

Visibility of the display

Visibility of the display on the Head-Up Display is influenced by:

- ▷ Certain seat positions.
- ▷ Items on the Head-Up Display cover.
- ▷ Sunglasses with certain polarisation filters.
- ▷ Wet road.
- ▷ Unfavourable lighting conditions.

If the image is shown distorted, have the basic settings checked.

Switching on/off

1. "Settings"
2. "Head-up display"
3. "Head-up display"

Switching the Head-Up Display ON/OFF.

Display

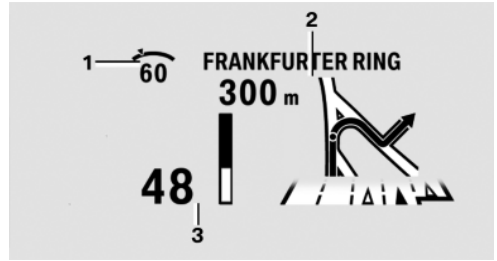

- 1 Desired speed
- 2 Navigation system
- 3 Speed

Selecting displays on the Head-Up Display

1. "Settings"
2. "Head-up display"
3. "Information displayed"
4. Select desired display on Head-Up Display.

The settings are saved for the remote control currently in use.

Adjusting brightness

The brightness is automatically adapted to the ambient light.

The base setting can be adjusted manually.

1. "Settings"
2. "Head-up display"
3. "Brightness"
4. Turn the controller.

Brightness is set.

The brightness of the Head-Up Displays can be additionally influenced using the instrument lighting, see page 90, if the low-beam headlights are switched on.

The setting is saved for the remote control currently in use.

Adjust height

1. "Settings"
2. "Head-up display"
3. "Height"
4. Turn the controller.

The height is set.

The setting is saved for the remote control currently in use.

Special windscreen

The windscreen constitutes part of the system.

The shape of the windscreen enables a precise projection.

A film in the windscreen prevents double images occurring.

For this reason, have the special windscreen replaced only by the Service centre.

Climate

Vehicle Equipment

This chapter describes all standard, national and special equipment provided in the model series.

Therefore equipment not available in a vehicle is also described, for example the selected special equipment or national version. That also applies to safety-relevant functions and systems.

Automatic air conditioning

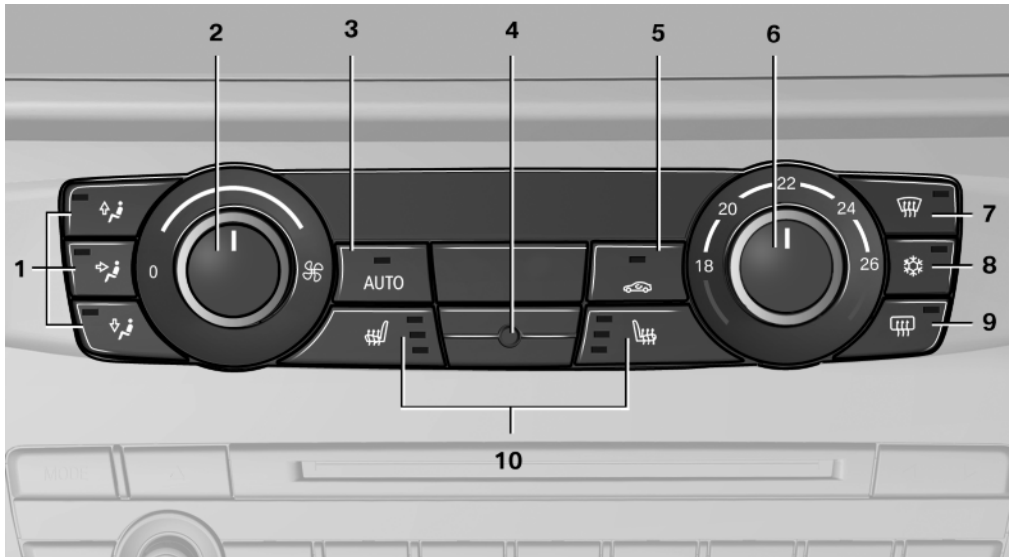

- | | |
|---|--|
| <ul style="list-style-type: none"> 1 Air distribution 2 Air flow 3 AUTO program 4 Interior temperature sensor — never cover 5 Recirculated-air mode 6 Temperature | <ul style="list-style-type: none"> 7 Defrosting windows and removing condensation 8 Cooling function 9 Heated rear window 10 Seat heating 47 |
|---|--|

Air conditioning functions in detail

Adjusting the air distribution manually

Press button to select a program:

- ▷  Window glass.

- ▷  Upper body area
- ▷  Footwell

Programs can be combined as desired.

Adjusting the air flow manually



Turn the wheel to select the desired air flow.

The heating or cooling power is more effective the greater the air flow.

In order to protect the battery the air flow rate of the automatic air conditioning is reduced, if necessary.

AUTO program



Press the button.

The air flow, air distribution and temperature are automatically regulated.

Depending on the selected temperature and external influences, the air is directed towards the windscreen, side windows, and upper body, and into the footwell.

The cooling function, see page 119, is switched on automatically in the AUTO program.

Recirculated-air mode

If the air outside the car has an unpleasant odour or contains pollutants, the supply to the interior of the car can be shut off. The air inside the car is then recirculated.



Press button repeatedly to call up an operating mode:

- ▶ LED off: ambient air is constantly entering the car.
- ▶ LED on, recirculated-air mode: the ambient air supply is permanently shut off.

In the event of condensation, switch off the recirculated-air mode and increase the air flow if necessary.



Continuous use of recirculated-air mode

Recirculated-air mode should not be used continuously for lengthy periods, as the quality of the air inside the car will otherwise gradually deteriorate. ◀

Temperature



Turn the wheel to select the desired temperature.

The automatic air conditioning sets this temperature as quickly as possible, using higher cooling or heating power if necessary. The temperature is then maintained.

Avoid switching between different temperature settings in rapid succession. The automatic air conditioning will otherwise not have sufficient time to establish the temperature selected.

Defrosting windows and removing condensation



Press the button.

This removes ice and condensation quickly from the windscreen and from the front side windows.

The air flow can be adapted when the program is active.

In the event of condensation, also switch on the air conditioning function.

Cooling function

The interior can only be cooled when the engine is running.



Press the button.

Air is cooled and dried, then reheated to suit the temperature setting.

Depending on weather conditions, the windscreen may mist over momentarily when the engine is started.

The cooling function is switched on automatically in the AUTO program.

When using the automatic air conditioning, condensation water, see page 141, develops that exits underneath the vehicle.

Heated rear window



Press the button.

The heated rear window is switched off automatically after a certain time.

Switching system on/off

Switching off

Turn rotary switch for air flow, see page 119, to 0. Blower and automatic air conditioning are fully switched off.

Switch on

Set desired air flow.

The automatic program can also be switched on directly using the AUTO button.

Microfilter

The microfilter traps dust and pollen in the incoming air.

This filter should be changed during maintenance on your vehicle, see page 260.

Automatic air conditioning with extended functionality

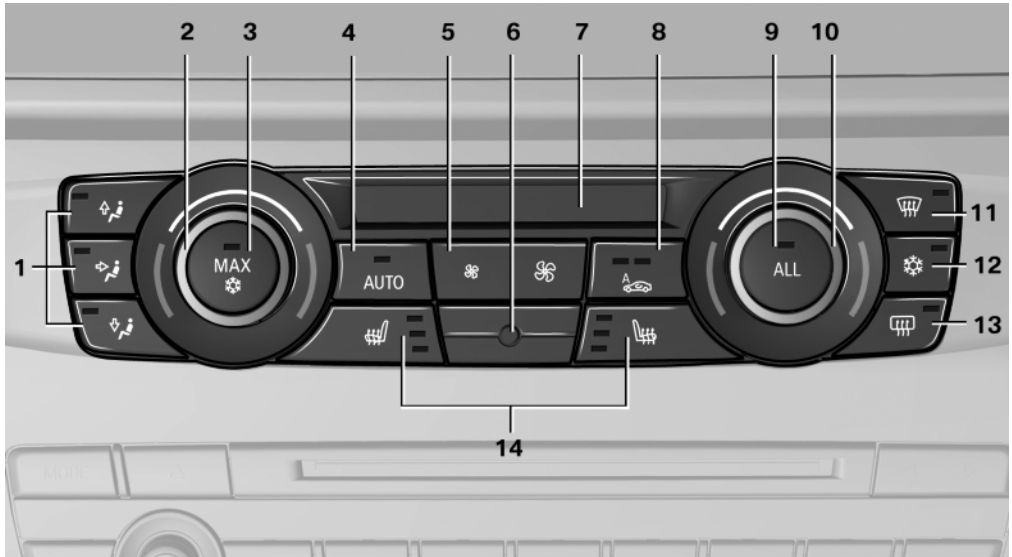

1 Air distribution

2 Temperature, left

3 Maximum cooling effect

4 AUTO program

5 Air flow, AUTO intensity

6 Interior temperature sensor — never cover

7 Display

8 AUC/recirculated-air mode

9 ALL program

10 Temperature, right

11 Defrosting windows and removing condensation

12 Cooling function



13 Heated rear window

14 Seat heating 47

Air conditioning functions in detail

Adjusting the air distribution manually

Press button to select a program:

- ▷  Window glass.
- ▷  Upper body area
- ▷  Footwell

Programs can be combined as desired.

Temperature



Turn the wheel to select the desired temperature.

The automatic air conditioning sets this temperature as quickly as possible, using higher cooling or heating power if necessary. The temperature is then maintained.

Avoid switching between different temperature settings in rapid succession. The automatic air conditioning will otherwise not have sufficient time to establish the temperature selected.

Maximum cooling effect



Press the button.

System is set to the lowest temperature, maximum air flow and recirculated-air mode.

The air flows from the outlets for the upper body area. These should therefore be left open.

With the engine running the air is cooled as quickly as possible.

The air flow can be adapted when the program is active.

AUTO program



Press the button.

The air flow, air distribution and temperature are automatically regulated.

Depending on the selected temperature, AUTO intensity and external influences, the air is directed towards the windscreen, side windows, and upper body, and into the footwell.

The cooling function, see page 122, is switched on automatically in the AUTO program.

A condensation sensor also controls the program so that condensation is avoided as much as possible.

To switch off program: press button again or manually adjust air distribution.

Intensity of AUTO program

With the AUTO program switched on, the automatic control of air flow and air distribution can be changed.



Pressing the button on the left or right reduces or increases intensity.

The selected intensity is shown on the display for automatic air conditioning.

Adjusting the air flow manually

To be able to regulate the air flow manually, first switch off the AUTO program.



Pressing the button on the left or right reduces or increases the air flow.

The selected air flow is shown on the display for automatic air conditioning.

In order to protect the battery the air flow rate of the automatic air conditioning is reduced, if necessary.

Automatic air recirculation control, AUC/recirculated-air mode

If the air outside the car has an unpleasant odour or contains pollutants, the supply to the interior of the car can be shut off. The air inside the car is then recirculated.



Press button repeatedly to call up an operating mode:

- ▷ LEDs off: ambient air is constantly entering the car.
- ▷ Left-hand LED on, AUC mode: a sensor detects pollutants in the outside air and shuts it out automatically.
- ▷ Right-hand LED on, recirculated-air mode: the ambient air supply is permanently shut off.

If there is condensation on the window, switch off recirculated-air mode and press the AUTO button to use the condensation sensor. Ensure that air can flow towards the windscreen.



Continuous use of recirculated-air mode
Recirculated-air mode should not be used continuously for lengthy periods, as the quality of the air inside the car will otherwise gradually deteriorate. ◀

ALL program



Press the button.

Current or subsequent temperature adjustments on the driver's side are transferred to the front passenger's side.

The program is switched off if the settings are changed on the front passenger side.

Defrosting windows and removing condensation



Press the button.

This removes ice and condensation quickly from the windscreen and from the front side windows.

The air flow can be adapted when the program is active.

If there is condensation on the window, switch on the cooling function as well or press the AUTO button to use the condensation sensor.

Cooling function

The interior can only be cooled when the engine is running.



Press the button.

Air is cooled and dried, then reheated to suit the temperature setting.

Depending on weather conditions, the windscreen may mist over momentarily when the engine is started.

The cooling function is switched on automatically in the AUTO program.

When using the automatic air conditioning, condensation water, see page 141, develops that exits underneath the vehicle.

Heated rear window



Press the button.

The heated rear window is switched off automatically after a certain time.

Switching system on/off

Switching off



In the lowest setting, press the left of the button.

Switch on

Press any button, except the buttons for ALL program or the heated rear window.

Microfilter/activated charcoal filter

In outside and recirculated-air mode, the microfilter/activated carbon filter filters dust, pollen and harmful gases from the air.

This filter should be changed during maintenance on your vehicle, see page 260.

Ventilation

Ventilation at front

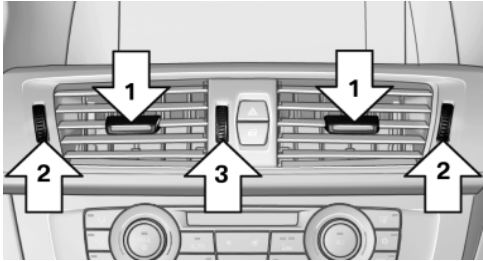

- ▶ Lever to change the direction in which air flows, arrow 1
- ▶ Knurled wheels to open and close the air outlets continuously, arrow 2
- ▶ Knurled wheel for varying the temperature, arrow 3.
Towards blue: cooler
Towards red: warmer.

Setting the ventilation

- ▶ Ventilation for cooling:
Adjust the outlets so that air is directed towards you, for example if the car's interior has become hot.
- ▶ Draught-free ventilation:
Adjust the outlets so that the air flows past you.

Ventilation in rear passenger compartment

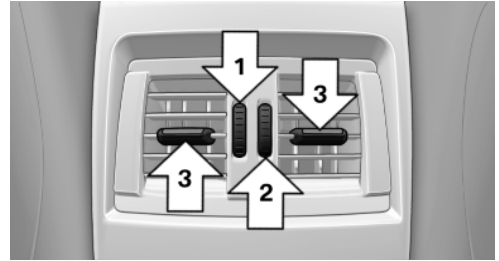

- ▶ Knurled wheel to open and close the air outlets continuously, arrow 1
- ▶ Knurled wheel for varying the temperature, arrow 2.
Towards blue: cooler
Towards red: warmer.
- ▶ Lever to change the direction in which air flows, arrow 3

Independent ventilation

Principle

The independent ventilation system ventilates the passenger compartment and lowers its temperature under some circumstances.

The system can be switched on and off at any ambient temperature either directly or via two preselected switch-on times. It remains switched on for 30 minutes.

Open the ventilation vents so the air can flow out.

Operation is done using the iDrive.

Switching on/off directly

1. "Settings"
 2. "Climate"
 3. "Activate ind. ventilation"
- ☞ Symbol on the automatic air conditioning system flashes when the system is switched on.

Preselecting the switch-on time

1. "Settings"
2. "Climate"
3. "Timer 1:" or "Timer 2:"
4. Set desired time.

Activating the switch-on time

1. "Settings"
2. "Climate"
3. "Activate timer 1" or "Activate timer 2"

☼ Symbol on automatic air conditioning is illuminated when switch-on time is activated.

☼ Symbol on the automatic air conditioning system flashes when the system has cut in.

The system switches on within the next 24 hours only. Afterwards, it must be reactivated.

Interior equipment

Vehicle Equipment

This chapter describes all standard, national and special equipment provided in the model series. Therefore equipment not available in a vehicle is also described, for example the selected special equipment or national version. That also applies to safety-relevant functions and systems.

Integrated universal remote control

Principle

With the integrated universal remote control, up to 3 functions of radio-controlled systems, for example, garage door drivers or lighting systems, can be operated. The integrated universal remote control thereby replaces up to 3 different hand-held remotes. For operation, the buttons on the interior mirror must be programmed with the desired functions. The relevant system is needed to program the hand-held remote.

 During programming

During programming and before a system is operated with the integrated universal remote control, make sure that no persons, animals or objects are within the swivelling or movement range of the system in question, as otherwise injury or damage could result.

Also follow the safety instructions supplied with the hand-held transmitter. ◀

Before you sell the vehicle, delete the saved functions beforehand for your own security.

Compatibility



If this symbol is depicted on the packaging or in the instruction manual of the system to be operated, this is usually compatible with the integrated universal remote control.

A list of compatible hand-held transmitters is available on the Internet: www.homelink.com

HomeLink is a registered trademark of Johnson Controls, Inc.

Control functions on the interior mirror

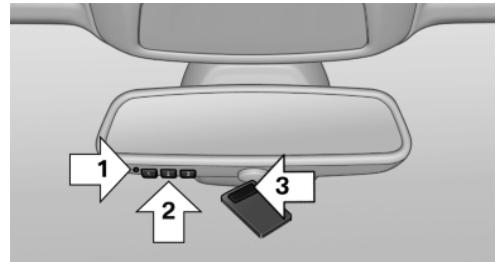

- ▷ LED, arrow 1.
- ▷ Buttons, arrow 2.
- ▷ Hand-held remote, arrow 3, is needed for programming.

Programming

General

1. Switch on ignition.
2. Initial operation:

Hold down the right and left button on the interior mirror at the same time for 20 seconds, until the LED on the interior mirror flashes. All programming of the buttons on the interior mirror is deleted.
3. Keep hand-held transmitter for the system to be operated approximately at a distance of 30 cm, 2 to 12 in to cm away from the buttons on the interior mirror. The gap required depends on the hand-held transmitter.
4. Hold down the button of the desired function on the hand-held transmitter and the buttons to be programmed on the interior

mirror at the same time. The LED on the interior mirror starts to flash slowly.

5. As soon as the LED flashes faster, release both buttons. The faster flashing shows that the buttons on the interior mirror have been programmed.

If the LED does not start to flash faster after at most 60 seconds, change the distance between the interior mirror and hand-held transmitter, and repeat the step. Several attempts at various distances may be necessary. Wait at least 15 seconds between attempts.

6. For programming other functions on other buttons, repeat steps 3 to 5.

The systems can be operated with the buttons on the interior mirror.

Special instruction for alternating-code radio systems

If the system cannot be operated after repeated programming, please check whether the system to be operated is equipped with an alternating-code system.

To do that, look this up in the instruction manual of the system or hold down the programmed button on the interior mirror for longer. If the LED on the interior mirror first flashes rapidly and then illuminates constantly for 2 seconds, the system is equipped with an alternating-code system. The flashing and illuminating of the LED repeats for approximately 20 seconds.

For systems with an alternating-code system, the integrated universal remote control and the system must also be synchronised.

Please find information on the synchronisation in the instruction manual of the system to be set.

Synchronising will be easier if another person is available to assist you.

Synchronising:

1. Park your car within the range of the radio-remote-controlled system.
2. The corresponding button on the interior mirror is programmed as described.
3. Locate the button for synchronisation on the system to be set and press. The next step must be carried out within approximately 30 seconds.
4. Hold down the programmed button on the interior mirror for 3 seconds and then release. Repeat this working step as needed up to three times to complete synchronisation. When synchronisation is completed, the programmed function is run.

Reprogramming individual buttons

1. Switch on ignition.
2. Press and hold the buttons on the interior mirror to be programmed.
3. As soon as the LED on the interior mirror flashes, hold the hand-held transmitter at a distance of 5 to 30 cm, 2 to 12 in from the buttons on the interior mirror. The gap required depends on the hand-held transmitter.
4. Press and also hold the button for the desired function on the hand-held transmitter.
5. As soon as the LED on the interior mirror flashes faster, release both buttons. The faster flashing shows that the buttons on the interior mirror have been programmed. Then the system can be operated on the interior mirror.

If the LED does not start to flash faster after at most 60 seconds, change the distance and repeat the step. Several attempts at various distances may be necessary. Wait at least 15 seconds between attempts.

Controls

⚠ Before operating

Before a system is operated with the integrated universal remote control, make sure that no persons, animals or objects are within the swivelling or movement range of the system in question, as otherwise injury or damage could result.

Also follow the safety instructions supplied with the hand-held transmitter. ◀

The system, for example, the garage door, can be operated using the button on the interior mirror when the engine is running or the ignition is switched on. To do this, hold down the button within the reception range of the system, until the function is triggered. The LED on the interior mirror illuminates constantly when the radio signal is being transmitted.

Deleting stored functions

Hold down the right and left button on the interior mirror at the same time for 20 seconds, until the LED flashes rapidly. All saved functions are deleted. It is not possible to clear functions individually.

Connecting electrical appliances

Note

⚠ Do not connect charger to socket

Do not connect battery charger to the sockets installed in the vehicle in the factory, otherwise this could damage the vehicle. ◀

Power sockets

Power sockets can be used for the operation of electrical devices with the engine running or the ignition switched on. The total load of all sockets must not exceed 140 Watt at 12 Volt.

To avoid damage to the socket, do not insert an incompatible plug.

Front centre console



Remove the cover.

Centre armrest

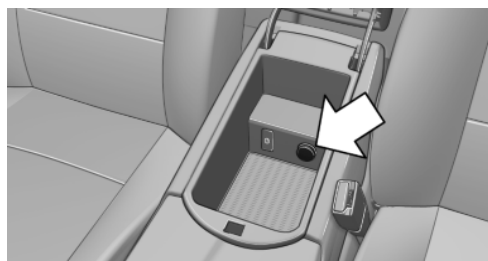

Remove the cover.

Rear centre console



Remove the cover.

Inside the boot

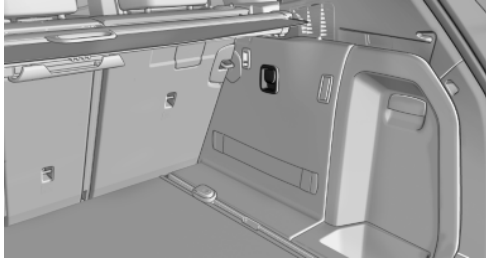

Socket is on the right in the boot.

Boot

Boot cover

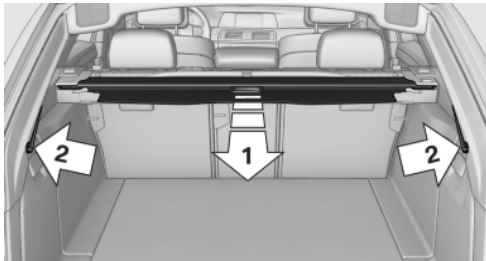

Remove boot cover, arrow 1, and hang on the brackets on both sides, arrow 2.

 **Hanging boot cover on both sides**
Hang boot cover on both sides, otherwise it can be damaged. ◀

 **Do not deposit any heavy objects**
Do not deposit any heavy and hard objects on the boot cover. Otherwise they could endanger vehicle occupants when braking or swerving, for instance. ◀

 **Do not permit the boot cover to roll rapidly closed**

Do not permit the boot cover to roll rapidly closed as this could result in damage. ◀

Removing and attaching

Boot roll-up cover without load area net: Removing

The cover can be removed for stowing bulky items.

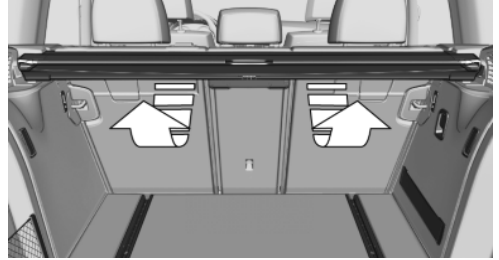

Reach under the cover and roll this upwards, following arrow. Pull cover backwards horizontally.

Boot roll-up cover with load area net: Removing

The cover can be removed for stowing bulky items.

1. Press button, arrow 1, to unlock cover.

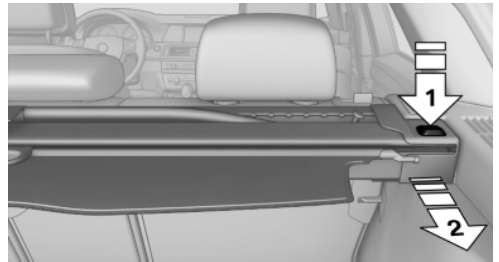

2. Pull cover backwards, arrow 2.

Inserting

Push cover in both side holders horizontally forwards until you hear it click.

The red warning panels disappear with the cover with separating mesh.

Pull sharply to check whether the cover is correctly engaged.

Expanding the boot

General

The boot can be enlarged by folding down the rear seat backrests.

The rear seat backrest is split 60–40.

With equipment with load-through system: The rear seat backrests is separated in the ratio 40–20–40.



Risk of trapping

Before folding the rear seat backrests, always check that there is nothing to obstruct their movement. When the centre section in particular is folded down, make sure that there is no-one in its movement zone and that no-one reaches into the movement zone of the rear seat backrests. Otherwise injury or damage might occur. ◀



Engaging the backrests

Before carrying persons in the back, ensure that the backrests are engaged and therefore locked into position. Otherwise the restraining effect of the seat belts may be restricted during an accident. ◀



Correctly engaging the catch

When swinging the panel back up, make sure that the catch engages properly. This will cause the red warning panel in the user interface to disappear. Otherwise, the transported load may be propelled inside the vehicle when braking or swerving and endanger the vehicle occupants. ◀



Use the middle seat belt

If the middle seat belt is used in the rear passenger compartment, the larger backrest half must be locked. Otherwise the seat belt will have no restraining effect. ◀

Fold down side

The right side can be folded down separately. The left side can be folded down together with the middle section.



Reach into the notch and pull forwards.

Folding down centre section



Reach into the notch and pull forwards.

Luggage net



Do not permit the luggage net to roll rapidly closed

Do not permit the luggage net to roll rapidly closed as otherwise there is a risk of injury and the luggage net could be damaged. ◀

Normal-sized boot

1. Fold open rear covers on the roofliner.
2. Grip the loop and pull the luggage net out of its cartridge.
3. Insert the rods on both sides forwards into the brackets in the roofliner from the out-

side, arrow. This is best done from the rear seat.

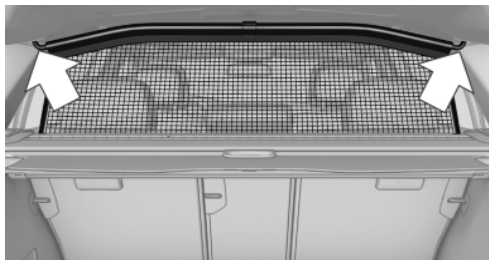

When the luggage net is no longer needed it: reverse the procedure.

Enlarged boot

1. Fold down the entire rear seat backrest.
2. Press the button, arrow 1, to disengage the cartridge at both sides.

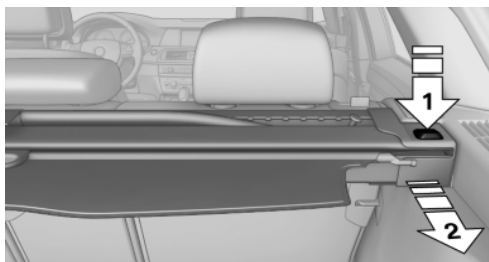

3. Remove the cartridge to the rear from both side brackets. Take care not to get the cartridge jammed.
4. Push the cartridge home in the guides, arrows 1 at the rear of the backrests.

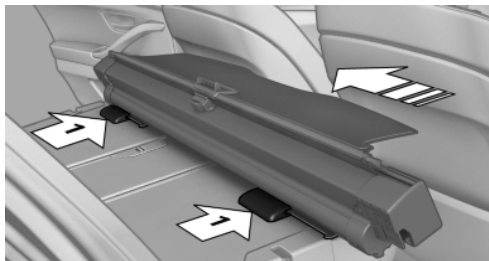

5. Fold open front covers on the roofliner.
6. Carefully pull out load area net and insert into the brackets as with a normal-sized boot, see page 129.

This is best done from the front seat.

When the luggage net is no longer needed it: reverse the procedure.

Finally, push the cartridge forwards in both side brackets, until it engages. The red warning panels disappear.

Pull sharply to check whether the cartridge is correctly engaged.

Storage compartments

Vehicle Equipment

This chapter describes all standard, national and special equipment provided in the model series. Therefore equipment not available in a vehicle is also described, for example the selected special equipment or national version. That also applies to safety-relevant functions and systems.

Notes



No loose objects in the interior.

Do not store any objects unsecured in the interior, otherwise they could endanger vehicle occupants when braking or swerving, for instance. ◀



No anti-slip matting on the instrument panel.

Do not use any kind of anti-slip matting on the instrument panel, otherwise it may be damaged by the materials of the matting. ◀

Storage options

The following storage options are located in the interior:

- ▷ Glove box on the passenger side, see page 131.
- ▷ Glove box on the driver's side, see page 132.
- ▷ Storage compartment in the front centre armrest, see page 132.
- ▷ Compartments in the doors.
- ▷ Pockets on the back rests of the front seats.
- ▷ Net in front passenger footwell

Glove box

Front passenger's side

Opening

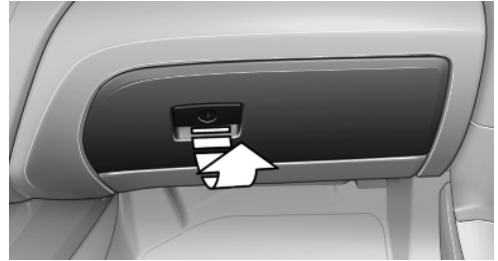

Pull the handle.

The light in the glove box comes on.



Close the glove box again immediately

After using the glove box while the vehicle is in motion, close it without delay, so that it cannot cause injury in the event of an accident. ◀

Closing

Swing lid up.

Locking

Use an integrated key, see page 28, to lock the glove box.

Then the remote control can be handed over without integrated key, e.g. in the hotel. Access to the glove box is not possible.

USB interface for data transfer

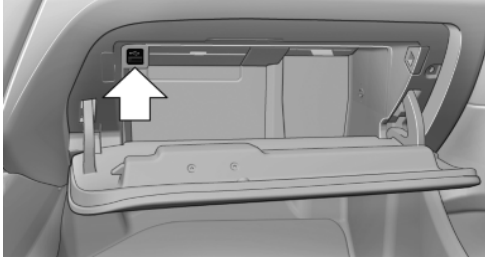

Connection for importing and exporting data on a USB medium, for example:

- ▷ Personal Profile settings, see page 31.
- ▷ Music collection, see page 188.
- ▷ With Professional navigation system: importing trips, see page 162.

When connecting, bear the following in mind:

- ▷ Do not insert the plug forcibly in the USB interface.
- ▷ Do not connect any devices such as fans or lights to the USB interface.
- ▷ Do not connect up USB hard drives.
- ▷ Do not use the USB audio interface for charging external devices.

Driver's side

Opening



Pull the handle.



Close the glove box again immediately after using the glove box while the vehicle is in motion, close it without delay, so that it cannot cause injury in the event of an accident. ◀

Closing

Swing lid up.

Pockets in the doors



Do not store any breakable objects. Do not store any breakable objects, for example, glass bottles, otherwise there is the increased risk of injury in the event of an accident. ◀

Centre armrest

Opening

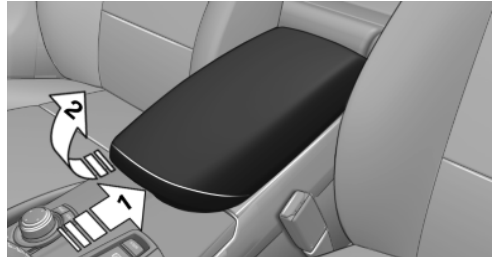

Press the button, arrow 1, and fold the centre armrest upwards, arrow 2.

Connection for external audio device

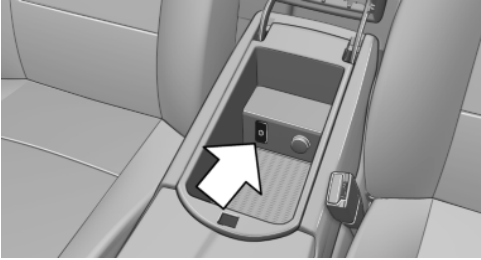

An external audio device, for example, MP3 player, can be connected.

- ▷ AUX-IN port, see page 193.
- ▷ USB audio interface, see page 194.

Cupholder

Notes

 Unbreakable containers and no hot beverages

Use light and unbreakable containers and do not transport hot beverages. Otherwise there is an increased risk of injury in the event of an accident. ◀

 Unsuitable containers
Do not force unsuitable containers into the cupholder. Otherwise damage may result. ◀

Front



Storage compartment in the front cupholder

Fittings for using the cupholder as an additional storage compartment. To do so, insert the fittings into the cupholder and engage.

Only use storage compartment for small objects, such as keys for example.

Rear

In the centre armrest.

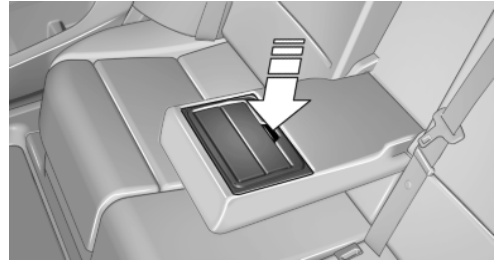

Pull centre armrest forward with the loop.

To open: press the button.

To close: push both covers back in one after the other.

 Push covers back into position
Push covers back into position before the centre armrest is folded up, otherwise the cupholder may become damaged. ◀

Coat hooks

The clothes hooks are located on the grab handles in the rear.

 Keep a clear view
Items of clothing hung from the hooks must not obstruct the driver's view. ◀

 No heavy objects
Do not hang heavy objects from the hooks as they could endanger the vehicle occupants, for example in the case of braking or evasive manoeuvres. ◀

Storage compartments in the boot

Storage space under floor panel

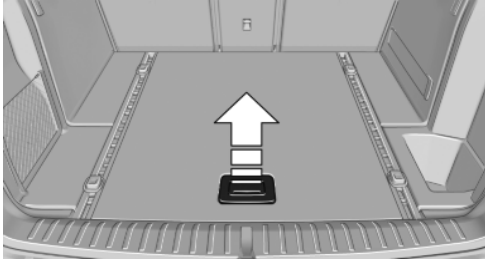

Folding up the floor panel. The storage space under the floor panel is divided into sections.

Two dividing elements can be used to further subdivide the space.

Side storage compartment, right

There is a watertight storage compartment on the right side of the floor of the boot.

Hooks/bag holders

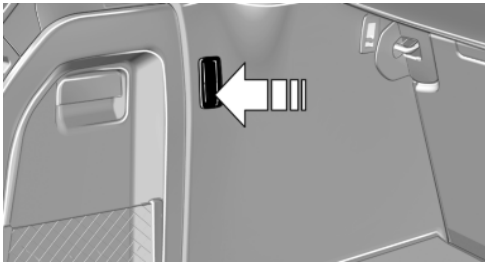

There are bag holders on the left and right-handpanels of the boot.

Tensioning strap

There is a tensioning strap on the right-hand trim panel for securing small objects.

Net

Smaller objects can be stowed in the net at the left side of the boot.

Side storage compartment left

To open: pull handle.

Lashing eyes in the boot

For securing the load, see page 142, lashing eyes are found in the boot.

Lashing eyes in the boot with rail

For securing the load, see page 142, lashing eyes are located in the boot.

Reversible base

The under side of the floor panel has a water and dirt-repellent coating.

Fold up the floor panel, remove and turn over.

Hooks on the lower side of the floor plate: for easier loading, the raised floor plate can be fastened with the hooks to the edge of the roof.

Boot net, FlexNet

For securing the load, see page 142, the flexible boot net can also be used.

Folding box

There is a folding box in the storage compartment under the floor of the boot.



Driving hints

The Driving hints chapter provides you with information that you may require in particular driving situations or operating modes.

Driving precautions

Vehicle Equipment

This chapter describes all standard, national and special equipment provided in the model series. Therefore equipment not available in a vehicle is also described, for example the selected special equipment or national version. That also applies to safety-relevant functions and systems.

Running in

General

Moving parts need a certain time to achieve maximum operating efficiency as a unit.

The following information helps to achieve maximum service life and efficiency of the vehicle.

Engine and final drive

Please observe the valid speed limit in the respective country you are travelling in.

Up to 2000 km, 1200 miles

Do not exceed the maximum engine revs and speed:

- ▶ For petrol engines, 4500 rpm and 160 km/h, 100 mph.
- ▶ For diesel engines, 3500 rpm and 150 km/h, 93 mph.

Avoid full throttle and do not use the automatic transmission kick-down.

From 2000 km, 1200 miles onwards

Engine and road speeds can be gradually increased.

Tyres

New tyres do not achieve their full road grip immediately, for production reasons.

During the first 300 km, 200 miles, drive moderately.

Brake system

Brake pads and discs only achieve a favourable wear and contact pattern after approximately 500 km, 300 miles. Drive moderately during this running-in period.

Clutch

The clutch only begins to function optimally at approx. 500 km, 300 miles. Engage the clutch gently during this running-in period.

After fitting new parts

The same running-in procedures should be observed if any of the components mentioned above have to be renewed in the course of the vehicle's operating life.

General driving notes

Closing the tailgate



Drive with the tailgate closed

Drive only with the tailgate closed, as otherwise the vehicle occupants and other road users could be at risk or the vehicle could be damaged in the event of an accident or if you have to brake abruptly or swerve to avoid an obstruction. There is also the danger of exhaust fumes entering the passenger compartment. ◀

If there is no alternative to driving with the tailgate open:

- ▶ Close all windows and the glass roof.
- ▶ Turn up the blower to a high output level.
- ▶ Maintain moderate speed.

Hot exhaust system

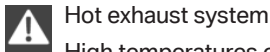

Hot exhaust system

High temperatures occur in the exhaust system.

Never remove the heat shields fitted here, or apply underseal to them. When driving, idling or parking, ensure that no highly inflammable materials, e.g. hay, foliage, grass etc. comes into contact with the hot exhaust system. It could ignite and cause a fire, with the risk of severe injuries or damage.

Do not touch hot exhaust tail pipes; otherwise there is a risk of burns. ◀

Diesel particle filter

The diesel particle filter collects soot particles and burns them periodically at high temperatures.

When cleaning for a few minutes, the following may occur:

- ▶ Engine temporarily runs a bit roughly.
- ▶ Noise and slight development of smoke from the exhaust shortly after shutting off the engine.
- ▶ The usual power output development requires a slightly higher engine speed.

Climate comfort windscreen

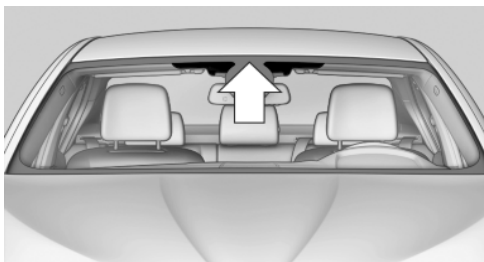

The marked area does not have a heat reflecting coating.

Use this area for garage-door openers, devices for electronic toll recording or similar.

Radio signals



Warning

The vehicle's performance may be affected by interference from high frequency radio signals. Such signals are output from a series of transmission systems, for example, from air traffic beacons or relay stations for mobile telecommunications.

We recommend you consult your Service Centre should you experience any difficulties. ◀

Mobile communication equipment



Mobile communication equipment

You are advised not to use mobile radio devices, for example, mobile phones, inside the vehicle without a direct connection to an external aerial. Mutual interference between the vehicle's electronics and such equipment cannot be entirely ruled out. There is moreover no guarantee that the radiation generated when such devices are transmitting will be dissipated out of the vehicle's interior. ◀

Aquaplaning

On wet or slushy roads, a wedge of water can form between the tyres and the road.

This situation, known as aquaplaning, means that the tyre can actually lose contact completely with the road surface and the car can neither be steered nor the brakes properly applied.



Aquaplaning

On wet or slushy roads, reduce your speed in order to avoid aquaplaning. ◀

Wading

If the water is calm drive no faster than walking speed and only up to a maximum water depth of approximately 50 cm, approx. 19.6 inches.

 Pay attention to the water depth and your speed

Do not exceed the water depth and walking speed, as otherwise the engine, electrical system and transmission could be damaged. ◀

Safe braking

Your vehicle is equipped with ABS as standard. Applying the brakes fully is the most effective way of braking in situations in which this is necessary.

The vehicle can be steered. Any obstacles can be avoided with steering wheel movements that are as calm as possible.

A pulsing of the brake pedal and hydraulic regulating sounds indicate that ABS is regulating.

Objects in the range of movement of the pedals

 No objects in the range of movement of the pedals

Foot mats, carpets or other objects must not breach the range of movement of the pedals, as otherwise they could influence the function of the pedals when driving.

Do not place additional foot mats on top of existing floor mats or other similar objects.

Only use foot mats that have been approved for the vehicle and that can be fastened accordingly.

Ensure that floor mats are securely reattached after having been removed, for example for cleaning. ◀

Wet roads

In damp weather or heavy rain, apply the brakes lightly every few kilometres/miles.

In doing so, do not obstruct other road users.

The resulting heat dries the brake discs and pads.

The braking force will be available immediately if needed.

Downhill gradients

When driving on long or steep downhill stretches, use the gear in which the least braking is required. Otherwise the brake system can overheat and braking action is reduced.

Manual gearbox:

The braking effect can be additionally increased by shifting down, even into first gear, if applicable.

Automatic transmission

The braking action of the engine can be boosted further by shifting down in the manual mode of the automatic transmission.

 Avoid excessive braking

Avoid excessive loads on the brake. Even slight, continuous pressure on the brake pedal could cause overheating, brake pad wear or even brake system failure. ◀

 Do not drive with the transmission in neutral

Never drive with the transmission in neutral or with the engine switched off. Otherwise, the braking action of the engine will either not be present, or there will be no power assistance to the brakes or steering. ◀

Corrosion of the brake disc

Corrosion of the brake discs and contamination of the brake pads increase with:

- ▷ Low mileage.
- ▷ Extended periods when the vehicle is not used.
- ▷ Infrequent use of the brakes.

Corrosion occurs when the minimum pressure that must be exerted by the pads during brake applications to clean the discs is not reached.

Should corrosion form on the brake discs, the brakes will tend to respond with a pulsating effect that generally cannot be corrected.

Condensate when vehicle is parked

When using the automatic air conditioning, condensation water develops that exits underneath the vehicle.

Traces of water on the ground are therefore normal.

Roof rack

Note

Fitting only possible with roof railing.

Roof racks are available as special equipment.

Fastening to the railing

Follow fitting instruction of the roof rack.

Fitting

Make sure that there is sufficient space to raise and open the glass roof.

Loads

A loaded roof rack alters the car's road behaviour and steering response by shifting its centre of gravity.

When loading and driving, bear the following in mind:

- ▷ Do not exceed permitted roof and axle load as well as the permitted gross weight.
- ▷ Distribute the roof load evenly.
- ▷ The roof load must not be spread over a large area.
- ▷ Place heavy items of luggage at the bottom.
- ▷ Securely fasten roof rack, e.g. with tensioning straps.
- ▷ Do not allow objects to protrude into the swing range of the tailgate.
- ▷ Drive smoothly and avoid sudden acceleration, braking or cornering.

Loads

Vehicle Equipment

This chapter describes all standard, national and special equipment provided in the model series. Therefore equipment not available in a vehicle is also described, for example the selected special equipment or national version. That also applies to safety-relevant functions and systems.

General

Overloading the vehicle

So that the permitted load capacity of the tyres is not exceeded, do not overload the vehicle. The tyres could then overheat and sustain internal damage. Under certain circumstances, sudden tyre pressure loss will be the consequence. ◀

No fluids in the boot

Ensure that fluid leakage does not occur in the boot. Otherwise the vehicle could be damaged. ◀

Loading

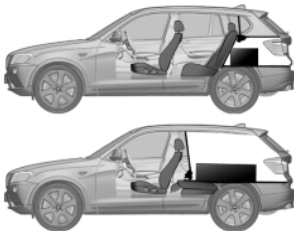

- ▷ Very heavy transported load: with no passengers on the back seat, insert both outer seat belts into the respective opposite buckles.
- ▷ Wrap protective material round sharp corners and edges.

- ▷ Do not stack storage goods above the upper edge of the backrests.
- ▷ Stow heavy transported loads as far forward and as low down as possible, directly behind the rear seat.
- ▷ Fully fold down the rear-seat backrest if the load is to be stowed accordingly.
- ▷ Use the luggage net, see page 129, to protect the vehicle's occupants. Make sure that objects cannot pass through the luggage net.
- ▷ Cover angular or sharp objects that could hit the rear window during the journey.

Securing the load

Lashing eyes in the boot

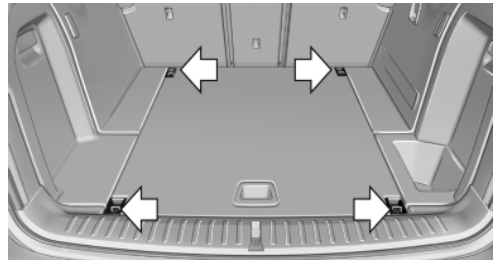

For securing the load, four lashing eyes are found in the boot

Lashing eyes in the boot with rails

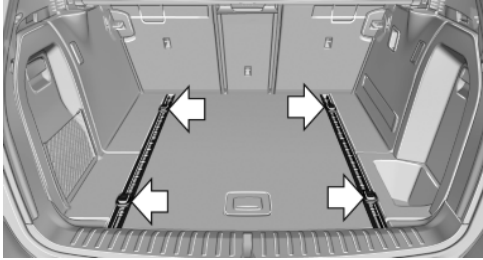

For securing the load, four moveable lashing eyes are found in the boot

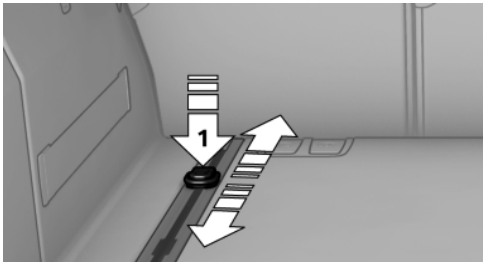

To reposition a lashing eye press the button, arrow 1. Ensure that the lashing eyes mesh into the new position.

The lashing eyes are stowed in the boot, beneath the hinged floor panel. They can be slotted into the rails at the recesses.

Boot net, FlexNet

The flexible boot net is suspended in eyes and secures the load in the boot. The storage net can be attached to the following eyes:

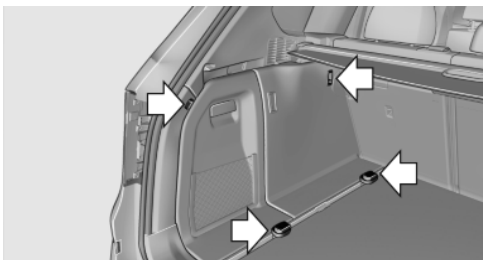

- ▷ Lashing eyes on the rail system.

- ▷ Eyes on the boot wall.

The eyes are located on both sides of the boot.

Securing transported loads

- ▷ Small and relatively light objects: can be retained with tensioning straps, a boot net or other suitable straps.
- ▷ Relatively large and heavy objects: secure with lashing straps.

Fasten tensioning straps of various kinds or boot nets to the lashing eyes in the boot.



Securing transported loads

Accommodate and secure the transported load as described above, otherwise it could endanger the vehicle occupants, for example, when braking and swerving.

Heavy and hard objects must not be stored unsecured in the interior, otherwise these could endanger the vehicle occupants, for example, when braking and swerving.

Do not exceed the permitted overall weight and permitted axle loads, otherwise the operational safety of the vehicle can no longer be guaranteed and the permit regulations are not met. ◀

Towing a trailer

Vehicle Equipment

This chapter describes all standard, national and special equipment provided in the model series. Therefore equipment not available in a vehicle is also described, for example the selected special equipment or national version. That also applies to safety-relevant functions and systems.

General

The permitted trailer load is indicated in the technical data.

Information on possibilities to increase the load can be provided by any Service centre.

The vehicle is equipped with reinforced springs on the rear axle and, depending on the type, with a more powerful engine cooling system.

For Australia/New Zealand

Towing

Australian standard AS 4177.1-2004 Caravan and light trailer towing components – towbars and towing brackets contains the following statement, which is hereby accepted by the BMW Group Australia: FOR TOWING ONLY. The trailer tow hitch supplied with your BMW vehicle should only be used for towing and not in connection with any kind of transport device attached to the trailer tow hitch, i.e. bicycle carriers or similar.

As all BMW Group towbar assemblies are designed, tested and approved as a single unit, the practice of modifying or replacing the BMW supplied towball mount assembly is not approved. Use only the genuine BMW towball mount assembly.

BMW Group Australia does not recommend or support the installation and use of a Weight Dis-

tribution Hitch or Load Levelling Device on any BMW Group vehicles. The use of such devices may affect the vehicle's warranty status.

We recommend you consult your Authorised BMW Dealer for any further advice or clarification.

Before a journey

Nose weight

- ▷ Minimum nose weight: 25 kg, 55 lb.
- ▷ Maximum nose weight: 100 kg, approx. 220 lb.

Where possible, make full use of this weight.

The weight of the trailer tow hitch and the nose weight reduce the maximum load of your car. The nose weight increases the vehicle weight.

The total permitted weight of the towing vehicle, see Technical data, must not be exceeded as a result.

Loads

Stow the load as low as possible and as close as possible to the axle.

A low centre of trailer gravity makes the vehicle combination much more stable and safe to drive.

The permitted total weight of the trailer and the permitted axle load of the vehicle (see Technical data) may not be exceeded. The smaller value is the limit which should be adhered to.

Tyre pressures

Check the vehicle's and the trailer's tyre pressures carefully.

On the vehicle, the tyre inflation pressure, see page 246, for higher loads applies.

For the trailer, the regulations of the manufacturer apply.

Runflat indicator

Reinitialise the runflat indicator after a trailer has been attached or detached or the inflation pressure has been corrected.

Exterior mirrors

Two exterior mirrors which bring both rear corners of the trailer into your field of view are required by law. Mirrors of this kind can be obtained from your Service centre as optional accessories.

Power consumption

The power output of the trailer's rear lights must not exceed the following values:

- ▷ Turn indicators: 42 Watts per side
- ▷ Rear lights: 60 Watts per side
- ▷ Brake lights: 84 Watts total
- ▷ Rear fog lights: 42 Watts total
- ▷ Reversing lights: 42 Watts total

Keep the switch-on times of the current consumer units in the caravan mode short in order not to place an excessive load on the vehicle battery.



Function of the rear lights

Before beginning your journey, check the function of the rear lights of the trailer, as otherwise this might endanger other road users. ◀

Towing a trailer

Notes



Appropriate speed when towing a trailer

Keep to an appropriate speed when towing a trailer. Speeds in excess of approximately 80 km/h, 50 mph can be enough to produce a swaying or fishtailing motion, depending on the design of the trailer and the load it is carrying. ◀



Maximum speed when towing a trailer

If you are towing a trailer, increase tyre pressures by 0.2 bar all round and do not exceed a top speed of 100 km/h / 60 mph, as the higher axle load could result in damage to the tyres if the car is driven at higher speeds. Note the maximum possible tyre pressures stated on the tyres. ◀

Counteracting snaking

If the trailer begins to snake, the vehicle combination can only be stabilised by braking hard immediately.

Make sure that the necessary steering corrections are carried out as cautiously as possible, taking other road users into consideration.

Uphill gradients

In the interest of safety and to avoid holding up other traffic, do not attempt to climb gradients steeper than 12 % when towing a trailer.

If higher trailer loads are permitted later, the limit is 8 %.

Downhill gradients

On downward inclines, a vehicle combination has tendency to snake at an earlier stage.

Before the downward incline, shift down to the next-lowest gear and drive downwards slowly.

High loads and high outside temperature



Long journeys with a high load and outside temperature

On long journeys with a high trailer load and high outside temperature, make sure that the fuel tank is more than 1/4 full, as otherwise the engine output can decrease or engine damage can occur. ◀

Trailer Stability Control

Principle

The system helps you to neutralise a trailer's tendency to swing from side to side.

It detects snaking movements and promptly brakes the vehicle so that road speeds fall to below the critical range and the vehicle combination is stabilised.

If the power socket for the trailer is in use but no trailer is attached, for example during use of a bicycle carrier with lights, the system may become active in extreme driving situations.

Operating requirements

The system is operational when towing a trailer and when using the trailer socket as of approximately 65 km/h, 40 mph.

System limits

- ▷ The system cannot intervene if the trailer veers instantly, for example on slippery or loose road surfaces.
- ▷ Trailers with a high centre of gravity can tip over before a swinging motion is detected.
- ▷ The system is not operational if Dynamic Stability Control DSC is deactivated or has failed.

Trailer tow hitch with electrical swivel-mounted ball head

General

The swivel-mounted ball head for the trailer tow hitch is located on the underside of the vehicle.

With the ignition switched off, the system is deactivated after a brief period. Therefore, only operate the system with the ignition switched on. The LED illuminates green if the system is operational.



The button for swinging the swivel-mounted ball head in and out is behind the rear side trim in the boot.

Swivelling out the ball head

1. Open the boot.
2. Step out of the swivelling area of the ball head behind the vehicle.
3.  Press the button in the boot. The ball head swivels outwards. The LED in the button flashes in green.
4. Wait until the ball head has reached the end position.



Checking the interlock

Before driving with a trailer or load carrier, make sure that the ball head is properly locked, as unstable driving conditions and/or accidents can otherwise result.

If the ball head is not properly locked, the LED in the button illuminates in red. ◀

Swivelling in the ball head

1. Uncouple the trailer or load carrier, remove the fittings for the track-stabilising devices, pull out the connector for the trailer's power supply and, if applicable, pull the adapter out of the socket. The LED in the button does not illuminate if the plug or adapter have not yet been pulled.
2.  Press the button in the boot.

The ball head swivels inwards. The LED in the button flashes in green.

3. Wait until the ball head has reached the end position.

Automatic interrupt of the swivel movement

The swivel movement is interrupted automatically if the current limit values are exceeded, for example at very low temperatures or in the case of mechanical resistance.

LED in button illuminates red.



Press the button until the ball head has reached the end position.

Trailer socket

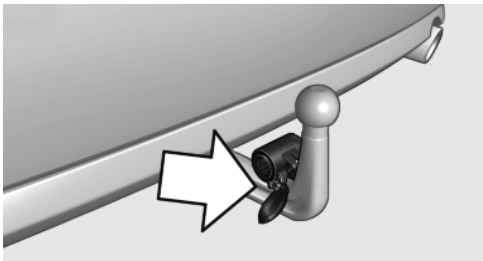

The trailer socket is located on the trailer tow hitch.

Fold the cover downwards.

Saving fuel

Vehicle Equipment

This chapter describes all standard, national and special equipment provided in the model series. Therefore equipment not available in a vehicle is also described, for example the selected special equipment or national version. That also applies to safety-relevant functions and systems.

General

Your vehicle contains wide-ranging technologies for reducing consumption and emission levels.

Fuel consumption depends on various factors. A number of measures, driving style and regular maintenance can influence the fuel consumption and the burden on the environment.

Removing transported load that is not required

Extra weight increases fuel consumption.

Removing add-on parts after use

Remove auxiliary mirrors, roof racks and rear-mounted racks after use.

Add-on parts on the car interfere with its aerodynamic performance and inflate fuel consumption.

Closing windows and the glass roof

An opened glass roof or opened window increases the drag coefficient and thus the fuel consumption.

Checking tyre pressures regularly

Check and, if necessary, correct tyre inflation pressures at least twice a month and before setting off on a longer journey.

Insufficient tyre inflation pressure enlarges the rolling resistance and thus increases fuel consumption and tyre wear.

Driving off immediately

Do not warm up the engine with the car at a standstill; it is preferable to set off straight away, driving at moderate engine speeds.

A cold engine will then reach its operating temperature faster.

Driving with foresight

Avoid accelerating and braking unnecessarily.

Keep an appropriate distance from the preceding vehicle.

Anticipating the road situation and adopting a smooth driving style will reduce fuel consumption.

Making use of coasting

On approaching a red traffic light, take your foot off the accelerator and allow the car to roll.

On downward stretches, take your foot off the accelerator and allow the car to roll.

The fuel supply is interrupted when coasting.

Switching off the engine when stationary

When you stop the car for longer periods, for example at traffic lights, railway crossings or in traffic jams, switch off the engine.

Auto Start Stop function

The Auto Start Stop function of your vehicle shuts off the engine automatically during a stop.

If the engine is switched off and then started again, the fuel consumption and emissions are reduced compared with a permanently running engine. Savings can be made just by stopping the engine for a few seconds.

By using this system, premature wear can be caused to certain components of the vehicle.

Fuel consumption also depends on other factors, such as driving style, road conditions, maintenance or environmental factors, for example.

Switching off functions that are not necessary at the moment

Functions such as seat heating or heated rear window require a great deal of energy and consume additional fuel, especially in city traffic and stop/go traffic.

For this reason, switch these functions off if they are not required.

Having the car serviced

Have the vehicle serviced regularly to achieve optimal economy and service life. It is recommended to have maintenance work performed by your Service centre.

See also the BMW Maintenance System, see page 260.

ECO PRO

Principle

ECO PRO supports a low energy consumption driving style. To do this, the engine control and comfort functions are adjusted, such as, for example, the air conditioning power.

In the instrument cluster, the extension of the range achieved as a result can be displayed.

Activate ECO PRO



Press the button until ECO PRO is displayed in the instrument cluster.

Display in the instrument cluster

ECO PRO bonus range

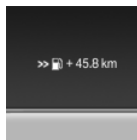

An extension of range can be achieved due to adjusted driving style.

This can be displayed as bonus range in the instrument cluster.

Configure ECO PRO

Via driver experience switch

1. "Settings"
2. "Driving mode"
3. "Configure ECO PRO"
4. Configure the program.

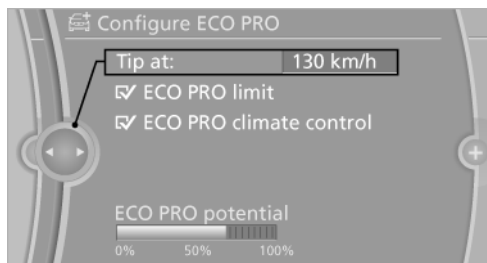

Via iDrive

1. "Settings"
2. "ECO PRO mode"

or

Configure the program.

ECO PRO tip

- ▷ "Tip at:":
Adjust ECO Pro speed, when an ECO PRO tip is shown.
- ▷ "ECO PRO limit":
A reminder is shown if the set ECO PRO speed is exceeded.

ECO PRO air conditioning

"ECO PRO climate control"

The air conditioning is adjusted for efficient fuel consumption.

A slight deviation from the temperature set and/or a longer heating up and/or cooling down of the interior is therefore possible, in order to lower consumption.

The power to the seat heating is also reduced.

ECO PRO Potential

It is shown how much percentage of the possible saving potential can be achieved with the current configuration.

Display on the Control Display

EfficientDynamics

When travelling, information on consumption and technology is shown.

1. "Vehicle information"
2. "EfficientDynamics"

Show fuel consumption history

The average fuel consumption can be shown in the set time span.

 "Consumption history"

Set time fuel consumption history time span

 Select symbol. Select symbol.

Reset fuel consumption history

1. Call up "Options".
2. "Reset consumption history"

Show EfficientDynamics Info

The current type of action can be shown.

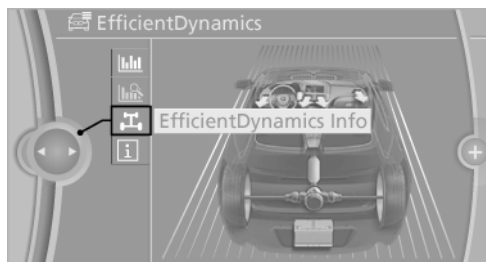

 "EfficientDynamics Info"

The following systems are shown:

- ▷ Auto Start Stop function.
- ▷ Energy recuperation.
- ▷ Air conditioning power.

Show ECO PRO tips

 "ECO PRO tips"

The setting is stored for the currently used profile.



Navigation

Various examples of how the navigation system reliably guides you to your destination are shown here.

Navigation system

Vehicle Equipment

This chapter describes all standard, national and special equipment provided in the model series. Therefore equipment not available in a vehicle is also described, for example the selected special equipment or national version. That also applies to safety-relevant functions and systems.

General

The navigation system can determine the precise position of the vehicle by means of satellites and vehicle sensors and guide you reliably to any specified destination.

Navigation data is saved in the vehicle and can be updated.

 Inputs when the vehicle is stationary
Only enter data when the car is stationary, and always obey the traffic regulations and road signs in the event of any contradiction between the traffic situation and the instructions given by the navigation system. You could otherwise commit an offence and put vehicle occupants and other road users at risk. ◀

Call up navigation system

-  Press the button on the controller.
- "Navigation"

 The navigation system can also be directly called up with the button on the controller.

Destination input

Manual destination input

General

When you are entering a town/city or street name, the system supports you with automatic name completion and input matching, see page 19.

Saved town/city and street names can be called up quickly.

- ▶ You can skip input of the country, town or city if you wish to retain previous inputs.
- ▶ If only the town/city has been entered, route guidance to the town/city centre is started.

Country input

- "Navigation"
- "Destination input"



3. Select "Country" or the country displayed.

Entering a town/city

1. Select "City/Postcode" or the town/city displayed.

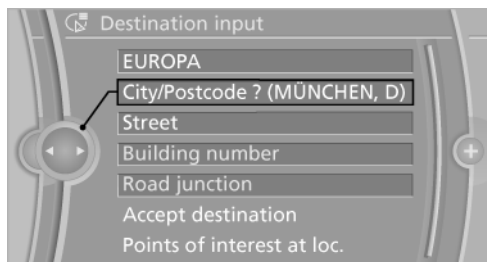

2. Select letters, if applicable.
The list is gradually narrowed down with each input.
3. Tilt the controller to the right.
4. Select the name of a town/city from the list.

If there are several places with the same name:

1. Move to the list of place names.
2. Highlight the town/city.
3. Select the town/city.

Entering the postcode

1. Select "City/Postcode" or the town/city displayed.
2. \uparrow @+ Select the symbol.
3. Select digits.
4. Move to the list of postcodes and towns/cities.
5. Mark entry.
6. Select an entry.

Entering a street and junction

1. Select "Street" or the displayed street.
2. Enter the street or junction in the same way as the town/city.

If there are several streets with the same name:

1. Move to the list of street names.
2. Highlight the street.
3. Select the street.

Alternatively, enter street and house number

1. Select "Street" or the displayed street.
2. Enter street in the same way as town/city.
3. "Building number"
4. Select digits.
5. Move to the list of house numbers.
6. Select the house number or a range of house numbers.

Road/street not in the destination

The desired road/street is not in the entered town/city because it is part of another city district.

1. "Navigation"
2. "Destination input"
3. Select "Street" or the displayed street.
4. Move to the list of street names.
5. "In" select country listed.

All the roads/streets of the selected country are offered. The respective town or city is shown after the street name.

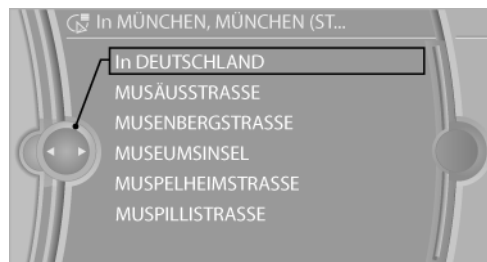

6. Select the letters.
7. Move to the list of street names.
8. Highlight the street.
9. Select the street.

Starting route guidance after destination input

1. "Accept destination"

2. "Start guidance" or "Add as another destination"

Enter, see page 161, destination as a further destination.

Address book

Selecting a destination from the address book

1. "Navigation"
2. "Address book"

Contacts with addresses are displayed if these addresses for the contacts have been checked as destinations.

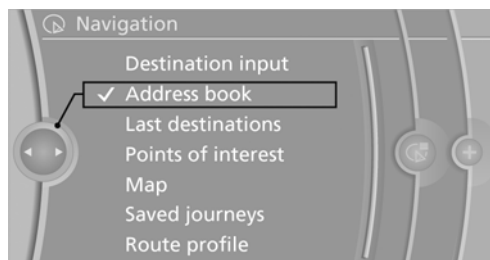

3. Select a contact from the list or use "A-Z search".
4. Where applicable, "Work address" or "Home address"

Saving a destination in the address book

After destination input, save the destination in the address book.

1. "Navigation"
2. "Map"
3.  "Guidance"
4. Call up "Options".

5. "Save as new contact" or "Add to existing contact"

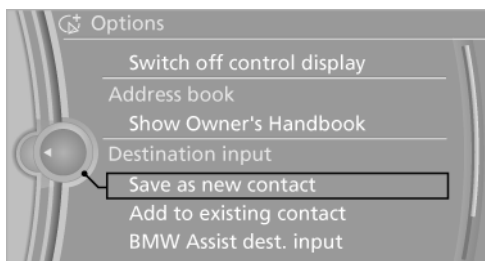

6. If applicable, select an existing contact.
7. "Work address" or "Home address"
8. Enter "Surname" and, if applicable, "First name".
9. "Save in car"

Saving position

The current position can be saved in the address book.

1. "Navigation"
2. Call up "Options".
3. "Save position as a contact" or "Add position to contact"

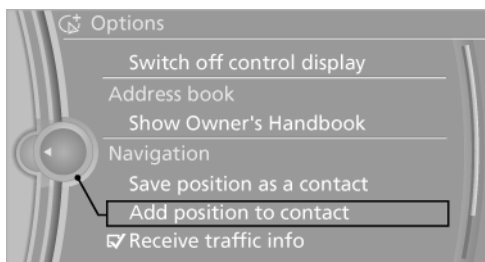

4. Select an existing contract from the list, depending on the selection. Select type of address and enter surname and first names.
5. "Save in car"

Edit or delete the address

1. "Navigation"
2. "Address book"

3. Mark entry.
4. Call up "Options".
5. "Edit in Contacts" or "Delete entry"

Accepting your home address as a destination

The home address must be created.

1. "Navigation"
2. "Address book"
3. "Home address"

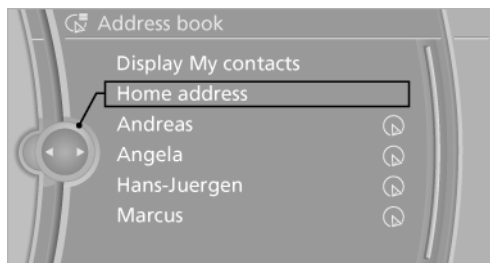

4. "Start guidance"

Last destinations

Overview

The last destinations reached are saved automatically.

These destinations can be called up and incorporated into route guidance.

Calling up last destinations

1. "Navigation"
2. "Last destinations"

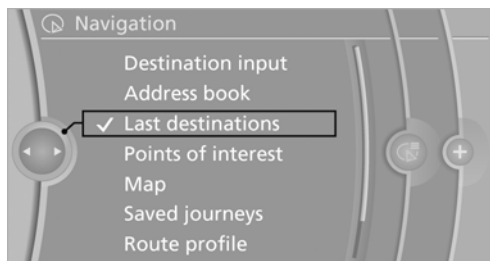

Starting route guidance

1. "Navigation"
2. "Last destinations"
3. Select destination.
4. "Start guidance"

Editing a destination

1. "Navigation"
2. "Last destinations"
3. Highlight destination.
4. Call up "Options".
5. "Edit destination"

Deleting the last destinations

1. "Navigation"
2. "Last destinations"
3. Highlight destination.
4. Call up "Options".
5. "Delete entry" or "Delete all last destinations"

Points of interest

General

Even with the most up-to-date navigation data, information on individual points of interest may have changed, for example, service stations may not be in operation.

Calling up the search for points of interest

Selection of points of interest, for example hotels or sights:

1. "Navigation"
2. "Points of interest"
3. Select search.

With Professional navigation system: Google™ Local Search

1. "Google™ Local Search"
2. "City"
Select or enter location.
3. "Keyword"
4. Enter keyword.
Suggestions are displayed.
5. Select suggestion.
The list of points of interest is displayed.
6. Select a point of interest.
Details are displayed.
If several details are included, you can browse through the pages.
If a phone number is saved, a telephone connection can be established.
7.  Select the symbol.
"Start guidance" or "Add as another destination"
Enter destination as a further destination, see page 161.

A-Z search

1. "A-Z search"
2. "City"
Select or enter location.
3. "Category"
4. Selecting a category.
5. "Category details"
With Professional navigation system: for some special destinations, several category details can be selected. Tilt the controller to the left to exit the category details.
6. "Keyword"
7. Enter keyword.
The list of points of interest is displayed.
8. Select a point of interest.
Details are displayed.

If several details are included, you can browse through the pages.

If a phone number is saved, a telephone connection can be established.

9.  Select the symbol.
"Start guidance" or "Add as another destination"
Enter destination as a further destination, see page 161.
"Start search": without entering a search term, the search is repeated using the last stored search term.

Category search

1. "Category search"
2. "City"
Select or enter location.
3. "Category"
4. Selecting a category.
5. "Category details"
With Professional navigation system: for some special destinations, several category details can be selected. Tilt the controller to the left to exit the category details.
Several category details can be selected for certain points of interest. Tilt the controller to the left to exit the category details.
6. "Start search"
The list of points of interest is displayed.
7. Select a point of interest.
Details are displayed.
If several details are included, you can browse through the pages.
If a phone number is saved, a telephone connection can be established.
8.  Select the symbol.
"Start guidance" or "Add as another destination"
Enter destination as a further destination, see page 161.

Displaying points of interest

List of points of interest: points of interest are arranged according to distance and marked with an arrow showing the direction.

In the Professional navigation system: in the split screen, points of interest from the selected category are displayed as symbols in the map view. The display depends on the scale of the map and the category.

Destination input via BMW Assist

A connection to the information service, see page 230, is established.

1. "Navigation"
2. "Destination input"
3. Call up "Options".
4. "BMW Assist dest. input"

With Professional navigation system: additional information on BMW Online

1. "Navigation"
2. "Points of interest"
3. Select a point of interest.
4. Call up "Options".
5. "Further info (BMW Online)"

Displaying points of interest in the map

To show symbols for the points of interest in the map view:

1. "Navigation"
2. "Map"
3. Call up "Options".
4. "Display points of interest"
5. Select the setting.

Destination input via map

Selecting a destination

1. "Navigation"
2. "Map"

The current position of the vehicle is shown in the map.

3.  "Interactive map"

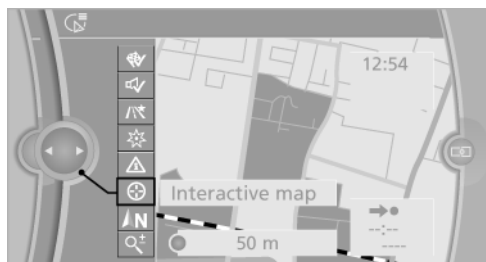

4. Select the destination with the cross-hairs.
 - ▶ To change the scale: turn the controller.
 - ▶ To move the map: tilt the controller in the corresponding direction.
 - ▶ To move the map diagonally: tilt the controller in the corresponding direction and turn it.

Specifying the street/road

If the system does not detect a street/road, one of the following items of information is displayed:

- ▶ A street name in the vicinity.
- ▶ The county.
- ▶ The co-ordinates of the destination.

Additional functions

Press the controller to access the following additional functions available in the interactive map:

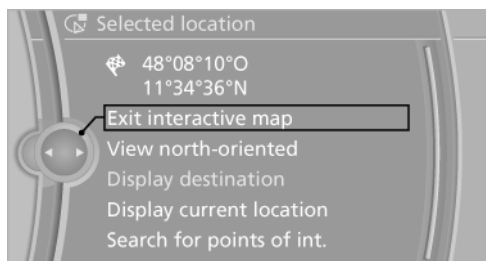

- ▶  Select the symbol.

"Start guidance" or "Add as another destination"

- ▷ "Exit interactive map": back to the map view.
- ▷ "View north-oriented" or "View direction of travel"
- ▷ "Display destination": map section around the destination is displayed.
- ▷ "Display current location": the map section around the current location is displayed.
- ▷ "Search for points of int.": search for points of interest is started.

Destination input by voice control

General

- ▷ Instructions for the voice control system, see page 21.
- ▷ A changeover between voice operation and iDrive is possible when entering destinations using spoken commands.
- ▷ Have possible voice commands read aloud: ›Voice commands‹

Voice commands

- ▷ With Professional navigation system: town, street and house number can be entered with a single command.
- ▷ Countries, locations, roads and junctions can be spoken as whole words in the language of the system, see page 84, or spelled out.
Example: to enter a town/city within Germany as an entire word, the language of the system must be German.
- ▷ Spell out the input if the language spoken and the language of the system differ.
- ▷ Pronounce letters fluently and avoid excessive intonation and pauses.
- ▷ The options for input depend on the specific navigation data, country and language settings.

With Professional navigation system: entering address in a command

1.  Press the button on the steering wheel.
2. ›Destination input‹
3. Wait for the system prompt.
4. Say the address aloud in the sequence suggested.
5. Continue input as specified by the system.
If required, say each part of the address separately, for example town/city.

Entering name of town/city on its own

The place name can be spoken as a word or spelled out.

When the destination input menu is displayed:

1.  Press the button on the steering wheel.
2. ›City‹ or ›Spell name of city‹.
3. Wait for the system to ask for the town/city.
4. Say the name of the town/city or say at least the first three letters.
Depending on the input, up to 20 towns/cities are suggested.
5. Select the town/city.
 - ▷ Selecting the suggested town/city: ›Yes‹
 - ▷ Selecting a different town/city: ›New entry‹
 - ▷ Select an entry, ›Entry ...‹, for example entry 2
 - ▷ Spell the input: ›Spell name of city‹
6. Continue input as specified by the system.

If there are several places with the same name:

Where applicable, places that sound the same are shown in a list and displayed as a place followed by three dots.

1. Select the entry: ›Yes‹ or ›Entry ...‹ e.g. Entry 2.
2. Select the desired location.

Entering street or junction on its own

Enter the street or junction in the same way as the town/city.

Entering house number on its own

Depending on the data present in the navigation system, house numbers up to 2000 can be entered.

1. ›Building number‹
2. Say the house number.
3. Continue input as specified by the system.

Planning trip with intermediate destinations

New trip

A trip can be planned using intermediate destinations.

1. "Navigation"
2. "Map"
3. If necessary, tilt the controller to the left.
4.  "Guidance"
5. "Enter new destination"
6. Select the mode of destination entry.

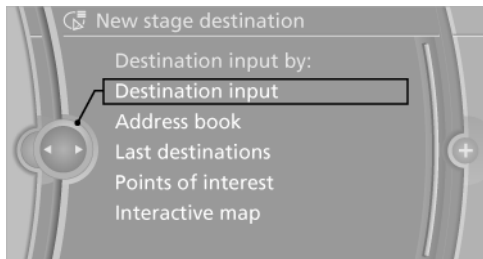

7. Enter an intermediate destination.
8. "Start guidance"

Entering a trip destination

For one trip, a maximum of 30 intermediate destinations can be entered.

1. "Enter new destination"
2. Select the mode of destination entry.
3. Enter an intermediate destination.
4. "Add as another destination"

The intermediate destination is added to the destinations list and is highlighted.

5. Turn the controller until the intermediate stop appears at the desired location in the list.
6. Press the controller.

Starting the trip

1. Highlight the first destination after entering all intermediate destinations.

If, for example, the second intermediate destination is the one highlighted when you start route guidance, the first intermediate destination is skipped.

2. "Start guidance"
 symbol indicates the active stage of the trip.

With Professional navigation system: save trip

Up to 30 trips can be stored in the trip list. If necessary, delete existing trips so that new trips can be saved.

1. Call up "Options".
2. "Save journey"
3. Enter names.
4. "OK"

With Professional navigation system: select stored trips

1. "Navigation"
2. "Saved journeys"
3. Select trip.
4. "Start guidance"

Reversing the trip direction

The intermediate destinations are shown in the list in reverse order.

1. "Map"
2.  "Guidance"
3. Call up "Options".
4. "Reverse stage dest. order"

Options for the intermediate destinations

1. "Map"
2.  "Guidance"
3. "Display all stage dest."
4. Select an intermediate destination.
 - ▷ "Edit destination"
 - ▷ "Reposition stage dest.": move the intermediate destination in the list.
 - ▷ "Delete stage destination"
 - ▷ "Go to the next stage dest."

Some options are not possible for some trips.

With Professional navigation system: deleting stored trips

1. "Saved journeys"
2. Highlight the desired trip.
3. Call up "Options".
4. "Delete all journeys" or "Delete journey"

With Professional navigations system: importing trips using USB media

1. Switch on ignition.
2. Insert a USB medium into the USB interface, see page 132, in the glove box.
3. "Navigation"
4. "Saved journeys"
5. "Import journeys"
6. "USB"
7. "OK"

The maximum number of trips that can be saved on the USB medium and in the navigation system together is 30, otherwise import is not possible.

With Professional navigation system: importing trips through BMW Online

1. "Navigation"
2. "Saved journeys"
3. "Import journeys"
4. "BMW Online"

With Professional navigation system: calling up last trip

1. "Navigation"
2. "Saved journeys"
3. "Last journey"
4. "Start guidance"

With Professional navigation system: Guided Tour

General

Recommended routes can be added to the route guidance, for example a holiday route.

Start Guided Tour

1. "Navigation"
2. "Saved journeys"

3. "Guided Tour search"



4. Select "Country" and "Region" or search criteria:
 - ▷ "Search for name"
 - ▷ "Search for nearest Tour"
5. If applicable, "Start search"
6. Select a guided tour.
7. "Start guidance"
8. "Start guidance"

End Guided Tour

1. "Navigation"
2. "Map"
3. "Guidance"
4. "Stop guidance"

Route guidance

Starting route guidance

1. "Navigation"
2. Enter destination, see page 154.
3. "Accept destination"
4. "Start guidance"
 - ▷ The route is displayed on the control display.
 - ▷ The distance to the destination/intermediate destination and the estimated time of arrival are shown in the map view.
 - ▷ Arrow view is displayed in the instrument cluster, in the Head-Up Display and control display as appropriate.

Ending route guidance

1. "Navigation"
2. "Map"
3. "Guidance"
4. "Stop guidance"

Continuing route guidance

If you did not reach your destination during the last journey, route guidance may be continued. "Resume guidance"



Route criteria

General

- ▷ You can influence the route that is calculated by selecting various criteria.
- ▷ You can change the route criteria as often as you like during destination input or during route guidance.
- ▷ Road types form part of the navigation data and are taken into account in route planning, for example avoid motorways.
- ▷ The suggested route can differ from your personal experience.
- ▷ The settings are saved for the remote control currently in use.
- ▷ With Professional navigation system: for Guided Tour the route criteria cannot be changed.
- ▷ Route guidance with traffic information, see page 169.

Altering route criteria

1. "Navigation"
2. "Map"
3. "Route criteria"
4. Select a criterion:
 - ▷ "Fast route": time-optimised route resulting from a combination of a route as short as feasible and fast roads.

- ▷  "ECO PRO route": optimised combination of the fastest and shortest route.
- ▷  "Short route": short route, without regard to time.
- ▷ "Alternative routes": alternative routes are suggested if possible when route guidance is active.

With Professional navigation system: the individual suggestions are marked in colour.

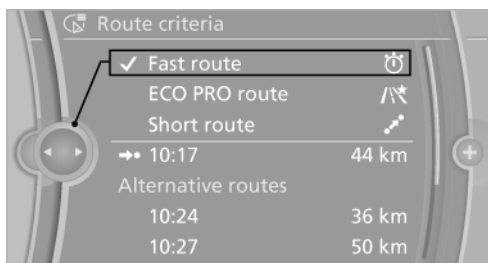

5. To select supplementary route criteria, if necessary:
 - ▷ "Avoid motorways": motorways are avoided as far as possible.
 - ▷ "Avoid toll roads": routes with tolls are avoided as far as possible.
 - ▷ "Avoid pre-paid roads": routes with long-term tolls are avoided as far as possible.
 - ▷ "Avoid ferries": ferries are avoided as far as possible.

Course of route

Various views of the course of the route are available during route guidance:

- ▷ Arrow display in the instrument cluster and on the control display.
- ▷ List of routine sections.
- ▷ Map view, see page 165.
- ▷ Arrow view in Head-Up Display, see page 116.

Arrow view

The following information is displayed during route guidance:

- ▷ Large arrow: current direction of travel.
- ▷ Road name of the road you are currently travelling along.
- ▷ Small arrow: indicator for next change of direction.
- ▷ Junction view.
- ▷ Driving lane information.
- ▷ Traffic information.
- ▷ Distance to the next change of direction.
- ▷ Street name during the next change of direction.

Driving lane information

In arrow view, a triangle indicates the recommended lane on a multilane carriageway.

- ▷ Solid triangle: optimal driving lane.
- ▷ Hollow triangle: other lane, acceptable at the moment. But a lane change might soon be necessary.

Display list of routine sections

With active route planning, a list of the route sections can be displayed. For each route stage, the distance to be driven and the traffic information are displayed.

1. "Navigation"
2. "Route profile"
3. Mark route section.

With Professional navigation system: the section of the route is shown in the split screen.

Bypassing a section of the route

Calculate a new route for a route stage.

1. "Navigation"
2. "Route profile"

3. "Create new route for"



4. Turn the controller. Enter the distance within which you want to return to the original route.
5. Press the controller.

Canceling a bypass

In case you no longer wish to bypass this section of the route:

1. "Navigation"
2. "Route profile"
3. "New route for:"
4. "Cancel new route"

Refuelling recommendation

The remaining range is calculated and, as needed, service stations along the way are displayed.

Even with the most up-to-date navigation data, information on individual service stations may have changed, for example, service stations may not be in operation.

1. "Navigation"
 2. "Route profile"
 3. "Recommended refuel"
- A list of service stations is displayed.

4. Highlight the service station.

With Professional navigation system: the position of the service station is shown in the split screen.

5. Select the service station.



6. Select the symbol.

7. "Start guidance": route guidance to the service station you selected is started.

"Add as another destination": the service station is added to the course of the route.

Switching spoken instructions on/off

The setting is saved for the remote control currently in use.

1. "Navigation"
2. "Map"
3.   "Spoken instructions"

Repeating spoken instructions

1. "Navigation"
2. "Map"
3.  Highlight the symbol.
4. Press the controller twice.

Volume of spoken instructions

Turn the volume knob during the voice instructions until the desired volume is obtained.

Saving voice instructions to favourites buttons

The function Enable/disable voice instructions can be saved to a favourites button, see page 19, for quick access.

Map view

Displaying map view

1. "Navigation"
2. "Map"

Overview

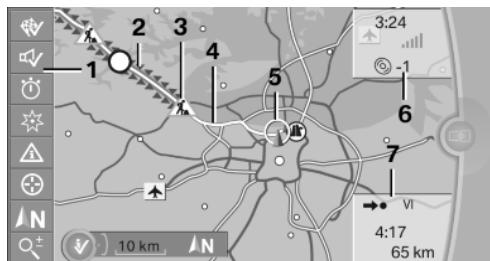

- 1 Function bar
- 2 Route stage with traffic obstruction
- 3 Road sign for traffic obstruction
- 4 Planned route
- 5 Location
- 6 Upper status field
- 7 Lower status field

Lines on the map

Roads and streets are displayed in various colours and lines in accordance with their classification. Dotted lines denote train and ferry connections. National borders are denoted by thin lines.

Traffic obstructions

Small triangles along the planned route denote route stages with traffic obstructions, depending on the map scale. The direction in which the triangle is pointing shows the direction of the obstruction.

Road signs classify the obstructions.

- ▶ Red road sign: the obstruction affects the planned route or direction of travel.
- ▶ Grey road sign: the obstruction does not affect the planned route or direction of travel.

Traffic information, see page [168](#).

Planned route

After starting route guidance, the planned route is shown on the map.

Status fields

Display/hide: press the controller.

- ▶ Upper status field: time, telephone and entertainment details.
- ▶ Lower status field: symbol for active route guidance, status of traffic information, arrival time and distance to destination.

Function bar

The following functions are available using the function bar:

Symbol	Function
	Start/stop route guidance.
	Switch spoken instructions on/off.
	Change route criteria.
	Search for point of interest.
	Displaying traffic information
	Interactive map.
	Set map view.
	Changes the scale.

To switch to the toolbar, tilt the controller to the left.

Changing map section

- ⊕ "Interactive map"
 - ▶ To move the map: tilt the controller in the corresponding direction.
 - ▶ To move the map diagonally: tilt the controller in the corresponding direction and turn it.

Changing the scale

1. Select the symbol.
2. To change the scale: turn the controller.

Automatically set scale

In the north-facing map view, turn the controller in any direction until the scale shows AUTO. The map shows the entire distance between the location and destination.

Settings for map view

The settings are saved for the remote control currently in use.

1. "Navigation"
2. "Map"
3. Call up "Options".
4. "Settings"

Set map view.

- ▷ "Day/night mode"

Selecting by light ratios and making settings.

"Traffic situation/grey map" Active: setting is not taken into account.

- ▷ With navigation system Professional:"Satellite images"

Depending on the availability and resolution, satellite images are displayed in scales of 2 km to 1000 km, approx. 1 mile to 600 miles.

- ▷ With navigation system Professional:"Perspective view in 3D"

Distinctive locations in the navigation data are shown on the map in 3D.

- ▷ "Traffic situation/grey map"

The map is optimised to the display of traffic information, see page 168. Symbols of points of interest are no longer displayed.

- ▷ With navigation system Professional:"Weather"

Weather symbols are displayed on the map when route guidance is active.

Displayed symbols: clear skies, overcast skies, rain, thunderstorms and snow, with the highest and lowest temperatures in each case.

The information is updated when starting or continuing route guidance or when changing the destination.

The symbols are displayed in specific selected scales.

With business navigation system: arrow view

The map is displayed on the control display.

1. Call up "Options".
2. "Arrow view on map"

The arrow view is shown on the map.

With business navigation system: position display

The current position is displayed on the Control Display as coordinate data or, if possible, with town and street.

1. Call up "Options".
 2. "Current position"
- Position is displayed.

With Professional navigation system: map view for split screen

Regardless of the main screen, the map view can be selected for the split-screen.

1. Call up "Options".
2. "Split screen"
3. Tilt the controller repeatedly to the right until the split screen is selected.
4. Select "Split screen display" or scale.
5. Select map view.
 - ▷ "Arrow view"
 - ▷ "Map north-oriented"
 - ▷ "Map indicating dir. of travel"
 - ▷ "Map perspective"
 - ▷ "Position"
 - ▷ "3D exit roads": selected exits are displayed three-dimensionally.

Adjustment also affects showing in the Head-Up Display.

▷ "Traffic situation/grey map"

- To change the scale: switch to split screen and turn controller.

With Professional navigation system: displaying photos for destination

Photos can be displayed for certain destinations when route guidance is active.

- "Navigation"
- "Map"
- "Guidance"
- "Pictures at destination"
- Depending on the offering, various photos can be selected.

Traffic information

Overview

General

- ▷ Allows traffic information from radio stations to be displayed that is transmitted by the Traffic Message Channel, TMC, of a traffic warning service. Information on traffic obstructions and dangers is continuously updated.
- ▷ Traffic information is displayed on the map by symbols.
- ▷ Traffic information for the vicinity is stored in a list.

⚠ The symbol in the function bar of the map view turns red if traffic information affects the calculated route.

Traffic information via BMW Assist

In several countries, BMW Assist realtime traffic information, RTTI, is transmitted.

With a valid BMW Assist contract, instead of the traffic information of the radio station, the traffic information of BMW Assist is displayed.

In countries in which BMW Assist does not transmit any traffic information, the traffic information of the radio station will continue to be displayed.

With the traffic information from BMW Assist traffic disruptions can be located more precisely. In addition, for example on routes which are clear with a radius of approximately 100 km, approx. 60 miles, are displayed more precisely around the current position.

⚠ The symbol in the function bar of the map view turns yellow, if the traffic information concerns the calculated route and the expected delay is less than 20 minutes. The symbol turns red if the expected delay is more than 20 minutes or the route is blocked.

"Traffic situation/grey map": information on traffic flow, for example, traffic jam or queuing traffic, are only shown in this setting of the map view, see page 169. The preview map in the list of the traffic information also shows this setting.

Switching reception on/off

- "Navigation"
- Call up "Options".
- "Receive traffic info"

Calling up the list of traffic information

- "Navigation"
- "Map"
- ⚠ "Traffic information"

The traffic information affecting the computed route is shown first. The various items of traffic information are sorted by distance from the vehicle's current position.

With traffic information from BMW Assist at the start of the list, information on diversions is also displayed.

- Select the item of traffic information.

 "More information": displays further information.

- If applicable, browse to the next or the preceding item of traffic information.

Traffic information in the map

General

"Traffic situation/grey map" Active: indications on the Control Display are toggled to grey-scale. This facilitates optimum traffic information display. Day/night mode is not taken into consideration for this setting. Symbols or points of interest are not displayed.

- "Navigation"
- "Map"
- Call up "Options".
- "Settings"
- "Traffic situation/grey map"

Symbols in the map view

Depending on the scale of the map and location of the traffic obstruction in relation to the route, the symbols for traffic obstructions are displayed.

Additional information in the map view

Depending on the scale, the length, direction and effect of a traffic obstruction are indicated by road signs in the map or bars along the calculated route.

- ▷ Red: traffic jam.
- ▷ Orange: queuing traffic.
- ▷ Yellow: heavy traffic.
- ▷ Green: free-flowing traffic.
- ▷ Grey: general traffic information, for example roadworks.

The information displayed depend on the specific traffic information service.

Filtering traffic information

Select the traffic information you want displayed on the map.

- "Navigation"
- "Map"
- Call up "Options".
- "Traffic info categories"
- Select the desired categories.

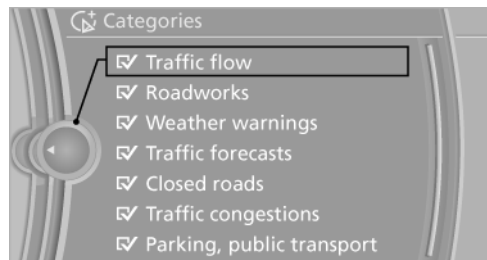

Traffic information in the selected category is displayed on the map.

- ▷ Traffic information affecting the route ahead are always shown.
- ▷ For the sake of safety, traffic information relating to potential hazards (vehicle driving in wrong direction on motorway, for example) cannot be hidden.

"Traffic flow": with traffic information from BMW Assist this category is not considered.

Route guidance with traffic information

General

Diversion suggestions from the navigation system may be taken manually with partially dynamic route guidance. With dynamic route guidance they are recorded automatically in the route guidance.

Partially dynamic route guidance

Partially dynamic route guidance is active when traffic information reception is switched on.

The systems takes into account the existing traffic information during the route guidance. A

message is displayed depending on the route, the traffic information and the possible diversion routes. If there is a traffic obstruction, a diversion is offered if possible.

The upper part of the message shows:

- ▷ Symbol of the first traffic disruption, or with distance to the start of the traffic disruption.
- ▷ Total length of traffic disruptions on the route.
- ▷ Extension of driving time due to traffic disruptions.

The lower part of the message shows:

- ▷ Diversion recommendation with distance to start of diversion.
- ▷ Difference in route length compared with original route.
- ▷ Time saved by the diversion compared with the original route with traffic disruptions.



In Professional navigation system: in the split screen, in addition to the original route, shown in white, the diversion is also shown.

Accepting a diversion

 "Detour"

For particular dangers, for example objects on the road, a message is displayed with no diversion option.

Diversions can also be accepted if the traffic messages are called up using the list.

1. "Navigation"
2. "Map"
3.  "Traffic information"
4. "Detour information"
5.  "Detour"

Dynamic route guidance

The route is automatically changed if a traffic obstruction is encountered.

- ▷ The system does not indicate traffic obstructions on the original route.

- ▷ Traffic information is still displayed on the map.
- ▷ Depending on the type of road and the nature and length of the traffic congestion, it is also possible that the route is calculated so that it cuts across the traffic congestion.
- ▷ Particular dangers are displayed independently of the setting.

Activating dynamic route guidance

1. "Navigation"
2. Call up "Options".
3. "Dynamic guidance"

With Professional navigation system: country information on BMW Online

Specific information on countries can be transferred via BMW Online, see page 232, for example speed limits on B roads.

1. "Navigation"
2. Call up "Options".
3. "Country info (BMW Online)"

Navigation data

Information on navigation data

1. "Navigation"
2. Call up "Options".
3. "Navigation system version" Information regarding the version of the data is displayed.

Updating navigation data

General

Navigation data is saved in the vehicle and can be updated.

You can obtain up-to-date navigation data and the activation code from your Service centre.

- ▷ Depending on the volume of data, updating the data can take several hours.

- ▷ Update while the vehicle is in motion, to save the battery.
- ▷ Only the basic functions of the navigation system are available while an update is in progress.
- ▷ You can check the status of the update process.
- ▷ After updating, the system reboots.
- ▷ Remove the media with navigation data after updating.

Professional navigation system: updating

1. Insert navigation DVD into the DVD player with the labelled side upwards.
2. Follow the instructions on the control display.
3. Enter activation code for the navigation DVD.
4. Change the DVD as needed.

After interrupting the journey, follow the instructions on the control display.

Business navigation system: updating

1. Insert a USB medium with navigation data into the USB interface in the glove box.
2. Follow the instructions on the control display.
3. Enter the activation code of the USB medium with navigation data.
4. Drive off.

After driving away, the system restarts and updates the navigation data while the vehicle is in motion.

The update resumes automatically in the background when you continue your journey.

Checking status

1.  Press the button.
2. "Navigation update"

What to do if...

- ▷ The current position cannot be displayed.
The car is in an area not covered by the data, is in a poor reception area or the system is currently calculating the position. Reception will normally be possible outdoors.
- ▷ A destination without a street is not transferred to the route guidance system.
No city centre can be determined for the place entered.
Enter any street in the place selected and start route guidance.
- ▷ A destination is not transferred to the route guidance system.
The data for the destination is not available in the navigation data. Choose a destination as close as possible to the original one.
- ▷ Letters cannot be selected for destination input.
The data stored do not contain the destination data.
Choose a destination as close as possible to the original one.
- ▷ Map view shown in grey scales?
"Traffic situation/grey map" Active: indications on the Control Display are toggled to grey-scale. This facilitates optimum traffic information display.
- ▷ Spoken instructions cease to be given immediately before junctions during route guidance?
Area is not fully recorded, or you have deviated from the suggested route and the system requires a few seconds to calculate a new route.



Entertainment

This chapter ensures your enjoyment when receiving radio and television stations or when playing CDs, DVDs and tracks from the music collection.

Sound

Vehicle Equipment

This chapter describes all standard, national and special equipment provided in the model series. Therefore equipment not available in a vehicle is also described, for example the selected special equipment or national version. That also applies to safety-relevant functions and systems.

General

The sound settings are saved for the remote control currently in use.

Treble, bass, balance, fader

- ▷ "Treble": treble adjustment.
- ▷ "Bass": bass adjustment.
- ▷ "Balance": left/right volume distribution.
- ▷ "Fader": front/rear volume distribution.

Setting the treble, bass, balance and fader

1. "CD/Multimedia", "Radio" or "Settings"
2. "Tone"



3. Select the desired sound setting.
4. Adjusting: turn the controller.
5. Saving: press the controller.

Equaliser

Setting for individual sound frequency ranges.

Setting the equaliser

1. "CD/Multimedia", "Radio" or "Settings"
2. "Tone"
3. "Equaliser"
4. Select the desired setting.

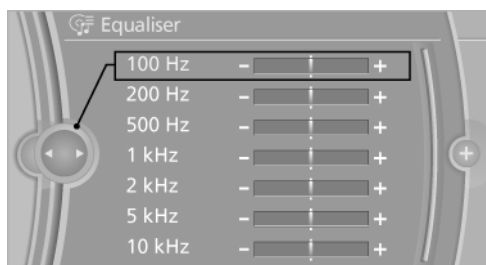

5. Adjusting: turn the controller.
6. Saving: press the controller.

Multichannel reproduction, surround

Choice of stereo and multichannel reproduction, surround.

Setting multichannel reproduction, surround

1. "CD/Multimedia", "Radio" or "Settings"
2. "Tone"

3. "Surround"

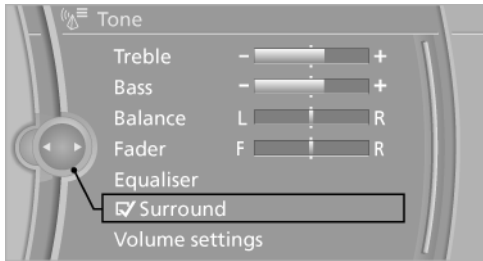

When surround is activated, multichannel reproduction is simulated when playing an audio track in stereo.

Volume

- ▶ "Speed volume": adaptation of the volume depending on speed
- ▶ "PDC": volume of the PDC sound signal relative to the sound output from the entertainment system.
- ▶ "Gong": volume of the sound signal, for example for seat belt reminder, in relation to the sound output from the entertainment system.
- ▶ "Microphone": microphone volume during a telephone call.
- ▶ "Loudspeak.": loudspeaker volume during a telephone call.

The following volumes are stored only for the respective connected telephone:

"Microphone", "Loudspeak."

Adjusting volumes

1. "CD/Multimedia", "Radio" or "Settings"
2. "Tone"
3. "Volume settings"

4. Select the desired volume setting.

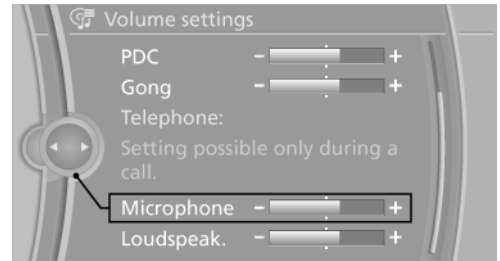

5. Adjusting: turn the controller.

6. Saving: press the controller.

Resetting the sound settings

1. "CD/Multimedia", "Radio" or "Settings"
2. "Tone"
3. "Reset"

Calling up sound settings using the Options menu

1. "CD/Multimedia" or "Radio"
2. Select further entries as needed, for example "FM" or "CD/DVD".
3. Call up "Options".
4. "Tone"
5. Set the desired sound.

Radio

Vehicle Equipment

This chapter describes all standard, national and special equipment provided in the model series. Therefore equipment not available in a vehicle is also described, for example the selected special equipment or national version. That also applies to safety-relevant functions and systems.

Control functions



- 1 Switching entertainment sources
- 2 Changing station/track
- 3 Favourites buttons
- 4 On/off, volume
- 5 Not for Australia/New Zealand: Traffic reports on/off
For Australia/New Zealand: toggle bandwidth

Sound output

Switching on/off

Press the on/off button on the radio when the ignition is switched off.

Muting

Press the on/off button on the radio with the ignition switched on or engine running.

AM/FM stations

Selecting station

1. "Radio"
2. "FM" or "AM"
3. Select the desired station.

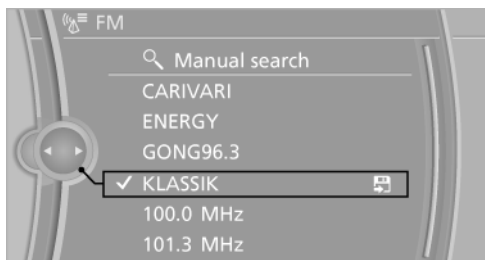

The selected station is saved for the remote control currently in use.

Changing stations



Press the button.

Saving stations

1. "Radio"
2. "FM" or "AM"
3. Highlight the desired station.

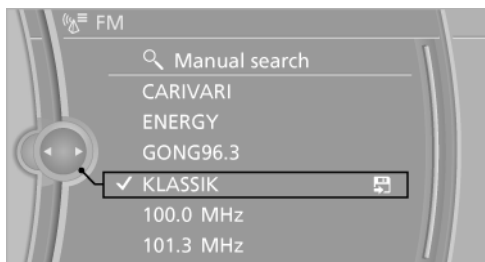

4. Press and hold down the controller.
5. Select the desired memory location.

The stations are saved for the remote control currently in use.

The stations can also be saved on the favourites buttons, see page 19.

Manual station selection

Station selection via frequency.

1. "Radio"
2. "FM" or "AM"
3. "Manual search"
4. Select another band as necessary.
5. To select the frequency: turn the controller.

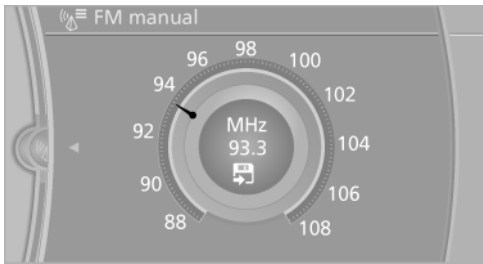

To save a station: press and hold down the controller.

Rename station

A station with changing station names can be renamed.

1. "Radio"
2. "FM"
3. Select the desired station.
4. Call up "Options".
5. "Rename as:"

Wait until the desired name is displayed.

The selected station name is in the list of current stations and the stored station is selected.

RDS

RDS broadcasts additional information in the FM waveband, for example the station name.

For a station with a number of frequencies, an automatic changeover to the frequency with the best reception quality takes place if required.

Switching RDS on/off

1. "Radio"
2. "FM"
3. Call up "Options".
4. "RDS"

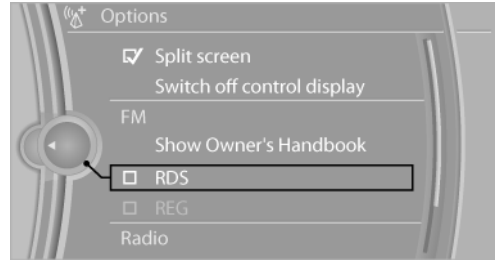

The setting is saved for the remote control currently in use.

Regional programmes

Certain FM stations broadcast regional programmes at certain times of day. The following settings are possible:

- ▷ REG function on:

Recommended setting.

The set regional programme is retained for as long as possible.

Reception quality may deteriorate when you go beyond its transmission area. If there is poor reception quality for a longer period, there is a switch to a regional programme with better reception.

- ▷ REG function off:

When you leave the transmission area for the regional station that is tuned, the radio changes over to a new regional station if available.

When in an area with at least two regional stations, the radio may switch between the stations. If this happens, switch on the REG function.

Switching REG function on/off

1. "Radio"
2. "FM"
3. Call up "Options".
4. "REG"

The setting is saved for the remote control currently in use.

Digital radio DAB, DAB/DMB

Principle

Digital stations are bundled into what are known as bouquets. Some stations feature additional programmes. Sports stations, for example, may broadcast various sports events at the same time.

Station search

The list of receivable stations will not be updated automatically. To perform an update, start the station search manually.

1. "Radio"
2. "DAB/DMB"
3. If applicable, "All ensembles"
4. "Station search"

Cancelling the station search

Call up any saved station via:

- ▷ Favourites buttons.
- ▷ "Saved stations"

Selecting station

1. "Radio"
2. "DAB/DMB"

3. Where applicable, select "All ensembles" or the desired ensemble.

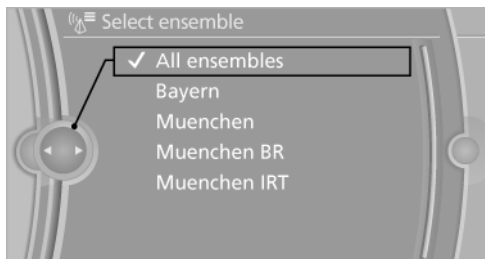

4. Select the desired station.

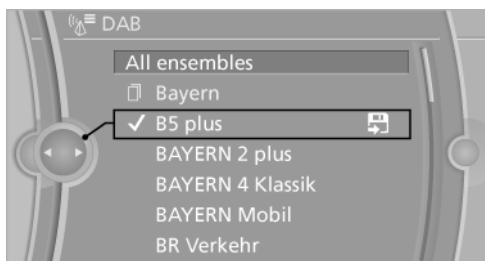

Changing stations

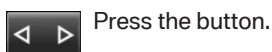

Changing the ensemble

It is only possible to change the ensemble if the following has been selected: "All ensembles".

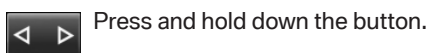

Saving stations

1. "Radio"
2. "DAB/DMB"

3. Select the desired station.



4. Press the controller again.
5. Select the desired memory location.

The stations are saved for the remote control currently in use.

The stations can also be saved on the favourites buttons, see page 19.

Displaying additional information

Some stations broadcast additional information in text form.

1. "Radio"
2. "DAB/DMB"
3. Select the desired station.
4. Call up "Options".
5. "Station information"

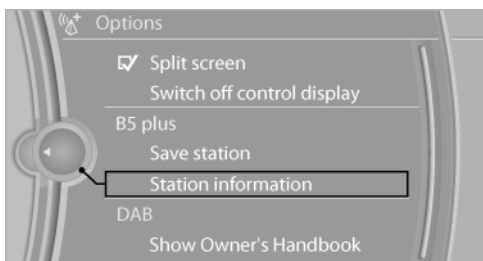

Automatic DAB/FM changeover

General

Does not work when equipped with rear entertainment.

With DAB/FM changeover activated, the radio automatically switches to a new station when the previous one can no longer be received.

First of all, a search is run for the station in another ensemble. If it is not available in another ensemble, the station's analogue frequency is searched for.

Automatic changeover is only possible if the corresponding station's signal is available in adequate quality and the IDs of the stations match.

Enabling automatic DAB/FM changeover

1. "Radio"
2. "DAB/DMB"
3. Call up "Options".
4. "Autom. DAB/FM changeover"

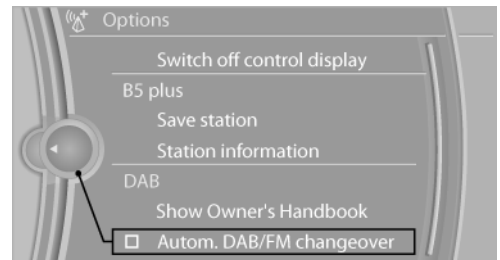

FM Symbol beside the station name indicates that a digital station is being played as analogue.

DAB Symbol beside the station name indicates that a digital station is being played as digital in another ensemble.

The setting is saved for the remote control currently in use.

Additional programmes

□ Symbol indicates that a selected station contains additional programmes. Sports stations, for example, may broadcast various sports events at the same time.

1. "Radio"
2. "DAB/DMB"
3. Select the desired station.

4. Press the controller.
5. Select the additional station.

Saved stations

General

Forty stations can be saved.

Calling up a station

1. "Radio"
2. "Saved stations"
3. Select the desired station.

Saving stations

The currently selected station is saved.

1. "Radio"
2. "Saved stations"
3. "Save station"

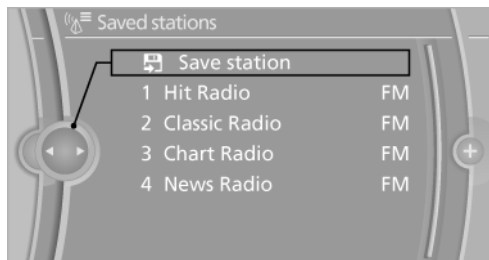

4. Select the desired memory location.

The list of saved stations is saved for the remote control currently in use.

The stations can also be saved on the favourites buttons, see page 19.

Deleting a station

1. "Radio"
2. "Saved stations"
3. Select the desired station.
4. Call up "Options".
5. "Delete entry"

Traffic reports

Display in the status field

- ▷ TP white: traffic radio switched on, traffic radio station available.
- ▷ TP grey: traffic radio switched on, no traffic radio station available.
- ▷ No display: Traffic Program is switched off.

Switching Traffic Program on/off



Press the button.

The traffic report station with the strongest reception is chosen.

The setting is saved for the remote control currently in use.

Interrupting a traffic report

Press one of the following buttons during a traffic radio report:

▷



▷



Adjusting the volume

Turn the volume knob during a traffic report until the desired volume is obtained.

CD/multimedia

Vehicle Equipment

This chapter describes all standard, national and special equipment provided in the model series. Therefore equipment not available in a vehicle is also described, for example the selected special equipment or national version. That also applies to safety-relevant functions and systems.

Controls

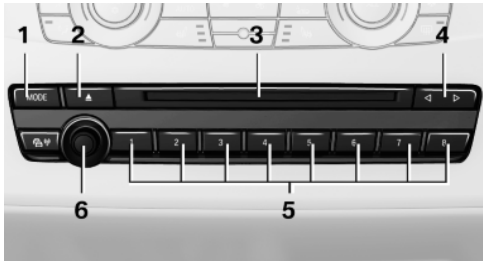

- 1 Changing entertainment source
- 2 Ejecting CD/DVD
- 3 CD/DVD player
- 4 Changing station/track
- 5 Favourites buttons
- 6 On/off, volume

Sound output

Switching on/off

Press the on/off button on the radio when the ignition is switched off.

Muting

Press the on/off button on the radio with the ignition switched on or engine running.

CD/ DVD

Playback

Inserting a CD/ DVD

Insert the CD/DVD with the label side uppermost.

The disk begins to play automatically.

It may take a few minutes to read compressed audio files.

Starting play

A CD/DVD is in the CD/DVD player or the DVD changer.

1. "CD/Multimedia"
2. "CD/DVD"
3. Select the desired CD or DVD.



Symbol	Meaning
	CD/DVD player
	DVD changer

Formats that can be played

- ▷ DVD: DVD-ROM, DVD-R, DVD+R, DVD-RW, DVD+RW, DVD-R DL, DVD+R DL, DVD-Audio (only video system), DVD-Video.
- ▷ CD: CD-ROM, CD-R, CD-RW, CD-DA.

- ▶ Compressed audio files: MP3, WMA, AAC, M4A.

Remove the CD/DVD

1.  Press the button.
The CD/DVD is pushed out slightly.
2. Remove the CD/DVD.

Playing audio tracks

Selecting a track using button

-  Press button repeatedly until the desired track is played.

Selecting a track using the iDrive

Audio CDs



Select the desired track to start playback.

CDs/DVDs with compressed audio files

Depending on the data, it might occur that not all characters on the CD/DVD are displayed correctly.

1. Select the directory as appropriate.

To change to a higher-level directory: tilt the controller to the left.

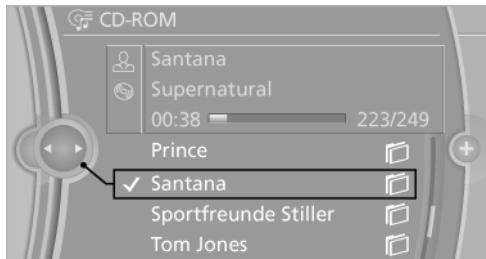

2. Select the desired track to start playback.

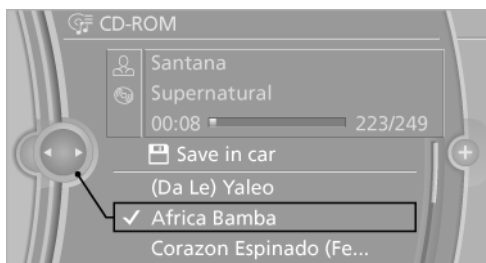

Displaying track information

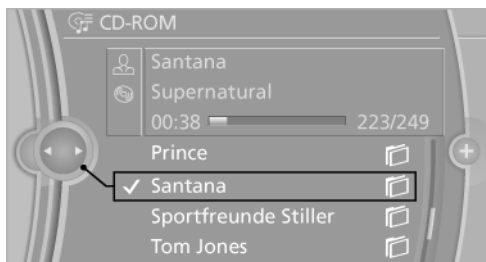

If information is saved for a track, this is displayed automatically:

- ▶ Artist.
- ▶ Album title.
- ▶ Number of tracks on the CD/DVD.
- ▶ File name of the track.

Random playback

1. "CD/Multimedia"
2. "CD/DVD"

3. Select the desired CD or DVD.
4. Call up "Options".
5. "Random"

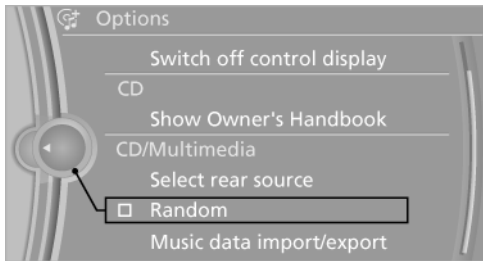

All the tracks on the CD/DVD are played in random order.

Fast forward/rewind



Keep button pressed.

Video playback

Country codes

Only DVDs with the code of your home region can be played. See also the information on your DVD.

Code	Region
1	USA, Canada
2	Japan, Europe, Middle East, South Africa
3	South-East Asia
4	Australia, Central and South America, New Zealand
5	North-West Asia, North Africa
6	China
0	All regions

Playback

The video image is shown on the front control display up to a speed of approximately 3 km/h,

2 mph. In some countries, it is only shown with the parking brake engaged or in gear position P.

DVD video

1. "CD/Multimedia"
2. "CD/DVD"
3. Select a DVD with video content.
4.  "DVD menu"









VCD/SVCD

1. "CD/Multimedia"
2. "CD/DVD"
3. Select a CD/DVD with video content.
4.  "Select track"
5. Select the desired title.

Video menu

To open the Video menu: turn the controller while the DVD is playing.

If "Back" is displayed, press the controller.

Symbol	Function
	Calls up the DVD menu.
	Starts playback.
	Pause
	Stop
	Next chapter
	Previous chapter

Symbol	Function
⏩	Fast forward
⏪	Rewind

For fast forward/rewind: each time the controller is pressed, the speed increases. To stop, start playback.

DVD menu

1. If necessary, turn the controller to call up the Video menu.
2. **DVD** "DVD menu"
The DVD menu is displayed. The display depends on the contents of the DVD.
3. To select menu items: tilt and press the controller.

To change to the Video menu: turn and press the controller.

Settings for DVD/VCD

For some DVDs, settings are only possible via the DVD menu, see also information on your DVD.

Selecting language

The languages available depend on the DVD.

1. Turn the controller while the DVD is playing.
2. Call up "Options".
3. "Audio/language"

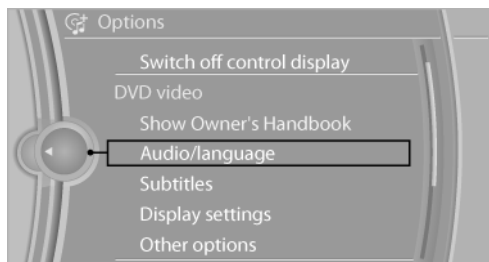

4. Select the desired language.

Selecting subtitles

The available subtitles depend on the DVD.

1. Turn the controller while the DVD is playing.
2. Call up "Options".
3. "Subtitles"
4. Select the desired language or "Do not display subtitles".

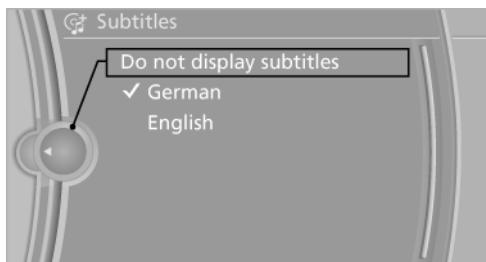

Setting the brightness, contrast, colour

1. Turn the controller while the DVD is playing.
2. Call up "Options".
3. "Display settings"
4. "Brightness", "Contrast" or "Colour"

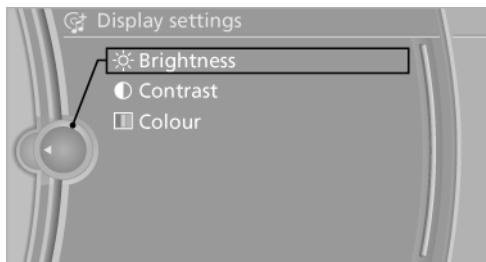

5. Turn the controller until the desired setting is reached and press the controller.

Selecting zoom

Display video picture over full screen.

1. Turn the controller while the DVD is playing.
2. Call up "Options".

3. "Other options"
4. "Zoom mode"

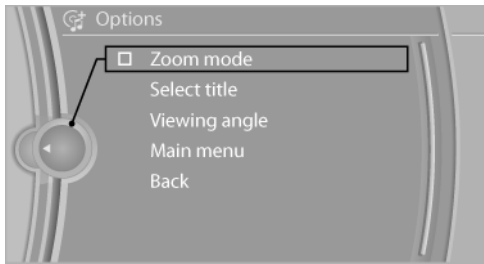

Selecting title

DVD video:

1. With the DVD menu displayed, turn the controller.
2. Call up "Options".
3. "Other options"
4. "Select title"
5. Select the desired title.

VCD/SVCD:

1.  "Select track"
2. Select the desired title.

Select camera angle

The availability of an alternative camera angle depends on the DVD and the current track on the DVD.

1. Turn the controller while the DVD is playing.
2. Call up "Options".
3. "Other options"
4. "Viewing angle"
5. Select the desired angle of view.

Calling up the main menu, Back

These functions are not included on every DVD. Therefore, they may not be available for use.

DVD changer

Inside the boot

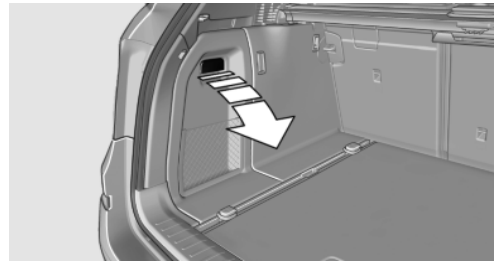

The DVD changer is located behind the left side trim in the boot.

Control functions and displays



- 1 Emptying the DVD compartments
- 2 LED on the DVD compartment
- 3 Buttons for DVD compartments
- 4 DVD compartment
- 5 Filling the DVD compartments

Filling the DVD compartments individually

1.  Press button once.
The LED on the first vacant compartment flashes.
2. Select a different compartment if necessary.
3. Wait until the LEDs on the DVD compartment flash.
4. Insert a single CD or DVD in the centre.

The CD/DVD is pulled in automatically and stored in the selected compartment.



Inserting CDs/DVDs

Only insert CD/DVD if the LEDs on the DVD compartment are flashing, otherwise the CD/DVD or the DVD changer could be damaged.

Do not force the CD/DVD into the drive; it could jam and you might not be able to eject it. ◀

Filling all the available DVD compartments

1.  Long press button once.

The LEDs on the vacant compartments flash.

2. Wait until the LEDs on the DVD compartment flash and then insert a CD or DVD, making sure it is centred.

The CDs/DVDs are drawn in automatically and stowed in the empty compartments.



Inserting CDs/DVDs

Only insert CD/DVD if the LEDs on the DVD compartment are flashing, otherwise the CD/DVD or the DVD changer could be damaged.

Do not force the CD/DVD into the drive; it could jam and you might not be able to eject it. ◀

It may take a few minutes to read the CDs/DVDs after loading.

Removing CDs/DVDs individually

1.  Press button once.
2. Select the DVD compartment.
The CD/DVD is pushed out slightly.
3. Remove the CD/DVD.

Removing all CDs/DVDs

1.  Long press button once.
2. Remove the CDs/DVDs.

Interrupt function

Filling the DVD trays or removing the CDs/DVDs may be interrupted.

Press the appropriate button.



Faults

If the LEDs on the DVD slot and the LEDs on the DVD trays flash rapidly, there is a fault.

Repairing the fault:

1. Press one of the following buttons:



The last CD/DVD inserted is pushed out slightly.

2. Remove the CD/DVD.

When the LEDs are no longer flashing quickly, the DVD changer is operational again.

Playing audio tracks

The audio track of a DVD can be played even if video playback is not possible in the vehicle.

Only the main film is played, without intro or extras.

Starting play

There is a DVD in the DVD changer.

1. "CD/Multimedia"
2. "CD/DVD"
3. Select the desired DVD.

Selecting a chapter using the button

 Press button repeatedly until the desired chapter is played.

Selecting a chapter using iDrive

1. "CD/Multimedia"
2. "CD/DVD"
3. Select the desired DVD.
4. Select the desired chapter.

Fast forward/rewind



Keep button pressed.

Selecting language

The languages available depend on the DVD.

1. "CD/Multimedia"
2. "CD/DVD"
3. Select the desired DVD.
4. Call up "Options".
5. "Audio/language"
6. Select the desired language.

Notes

CD/DVD player and changer



Do not remove the cover

All BMW CD/DVD players and changers are Class 1 laser products. Do not operate when the cover is damaged, otherwise it could cause severe eye injuries. ◀

CDs and DVDs



Using CDs/DVDs

- ▶ Do not use CDs/DVDs with adhesive labels that have been affixed subsequently, as these may peel off while in the drive as a result of the temperatures to which these media are exposed during playing. This could damage the system irreparably.
- ▶ Use only round CDs/DVDs with a standard diameter of 12 cm, 5 in and do not use CDs/DVDs in conjunction with adapters, for example CD singles. Otherwise the CDs or the

adapter could jam and be impossible to eject.

- ▶ Do not use combined CD/DVDs, for example DVD Plus, as otherwise the CD/DVD could jam and be impossible to eject. ◀

General malfunctions

- ▶ The CD/DVD players and changers have been optimised for operation in your vehicle. In some instances, they may be more sensitive to faulty CDs/DVDs than devices for stationary use.
- ▶ If a CD/DVD cannot be played back, first check whether it has been inserted correctly.

Atmospheric humidity

The CD/DVD or the focussing lens can carry condensation due to high humidity and playback may temporarily not be possible.

Malfunctions with individual CDs/DVDs

If malfunctions occur only with individual CDs/DVDs, this can be due to one of the following:

Self-recorded CDs/DVDs

- ▶ With self-recorded CDs/DVDs, possible causes include inconsistent data-creation or burning process, low quality or high age of the CD/DVD blank.
- ▶ Only write on the upper side of CDs/DVDs using a special marker pen.

Damage

- ▶ Avoid causing fingerprints and protect against dust, scratches and moisture.
- ▶ Store CDs/DVDs in a case.
- ▶ Do not expose CDs/DVDs to temperatures above 50 °C/122 °F, high levels of humidity or direct sunlight.

CDs/DVDs with copy protection

CDs/DVDs are often copy-protected by the manufacturer. This could result in CDs/DVDs being impossible to play, or only being playable with restrictions.

MACROVISION

This product contains copyrighted technology based on a number of registered US patents and intellectual property of the Macrovision Corporation and other manufacturers. The use of this copy protection must be approved by Macrovision. Media with the corresponding protection – unless otherwise agreed with Macrovision – may only be shown privately. It is prohibited to copy this technology.

DTS Digital Surround™

 Manufactured under licence of US patent numbers: 5,451,942; 5,956,674; 5,974,380; 5,978,762; 6,487,535 & and other patents issued and applied for in the USA and worldwide. DTS and the logo are registered trademarks & DTS Digital Surround and the DTS logos are trademarks of DTS Inc. © DTS, Inc. All rights reserved.

Music collection

Music memory

General

Tracks from CDs/DVDs and USB media can be saved in the music collection on a hard disk in the vehicle and played from there.

- ▶ Audio CD: tracks are converted into a compressed audio format. Information on the album, for example artist, is saved, if applicable.
- ▶ CD/DVD or USB medium with compressed audio files: the entire content of the CD/DVD or USB medium is saved as an album in the vehicle. WMA, MP3, M4A and AAC formats are saved. Tracks and directories can be de-

leted later individually, Delete tracks and directory, see page 192.

Tracks with copy protection, DRM, are saved, but cannot be played.



Backing up music data

Back up music data regularly, as otherwise it could be lost in the event of a fault in the hard disk. ◀



Music recognition technology and related data are provided by Gracenote®. Gracenote is the industry standard in music recognition technology and related content delivery. For more information, please visit www.gracenote.com.

CD and music-related data from Gracenote, Inc., copyright © 2000-2009 Gracenote. Gracenote Software, copyright © 2000-2009 Gracenote. This product and service may practice one or more of the following U.S. Patents: #5,987,525; #6,061,680; #6,154,773, #6,161,132, #6,230,192, #6,230,207, #6,240,459, #6,330,593, and other patents issued or pending. Some services supplied under license from Open Globe, Inc. for U.S. Patent: #6,304,523.

Saving from CD/DVD

1. Insert a CD or DVD in the CD/DVD player.
2. "CD/Multimedia"
3. "CD/DVD"
4.  Select the symbol for the CD/DVD player.
5. "Save in car"

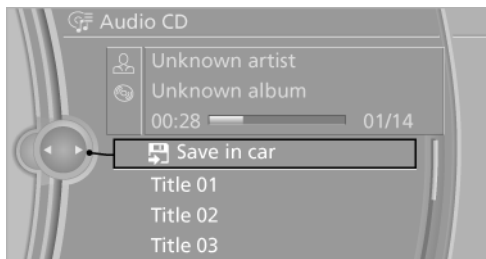

The music collection is displayed and the first track of the CD/DVD is played. The tracks are played in the normal order during saving.

During saving, bear the following in mind:

Do not switch to the CD/DVD player and do not remove the CD from the CD/DVD player, as otherwise saving is interrupted. It is possible to change over to the other audio sources without interrupting saving. Tracks of the current CD/DVD that have already been saved can also be called up.

Interrupting saving

1. "CD/Multimedia"
2. "CD/DVD"
3. "Saving..."

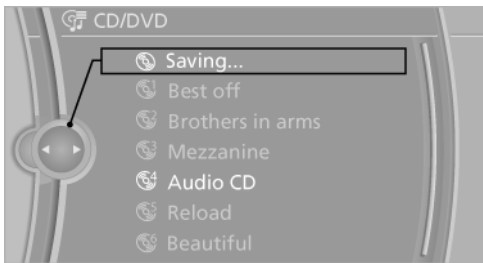

4. "Cancel saving"

The saving process is interrupted and can be continued at any time.

Resuming saving

1. "CD/Multimedia"
2. "CD/DVD"
3. Select the symbol for the CD/DVD player.
4. "Continue saving"

CD/DVD saving is continued at the start of the track for which saving was interrupted.

Information on the album

During the saving process, the information, for example the name of the artist, is saved for the tracks if this information is available in the database in the vehicle or on the CD.

To update the database, contact your Service centre.

If the titles do not stored any information, the entire album information, see page 192, of the CD may be updated using BMW Online.

Saving from a USB medium

To save music, a suitable medium must be connected to the USB interface in the glove box.

- ▷ Suitable media: USB mass storage facilities, for example USB memory sticks or MP3 players with USB interface.
- ▷ Unsuitable media: USB hard disks, USB hubs, USB memory card readers with a number of bays, Apple iPod/iPhone. Music from an Apple iPod/iPhone can be played using the USB audio interface in the centre armrest.
- ▷ File systems: current file systems for USB devices are supported. FAT 32 format is recommended.

1. Connect the USB medium to the USB interface in the glove box, see page 132.
2. "CD/Multimedia"
3. "Music collection"
4. Call up "Options".
5. "Music data import/export"
6. "Import music (USB)"

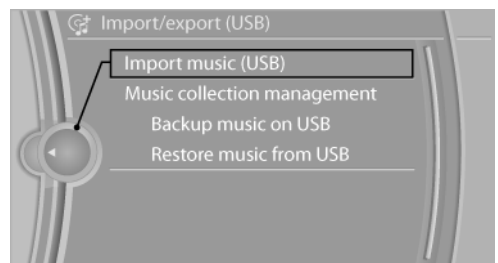

Playing music

Music search

All tracks for which information is saved can be called up via music search. All tracks for which

no information is saved can be called up via the corresponding album, see page 191.

1. "CD/Multimedia"
2. "Music collection"
3. "Music search"

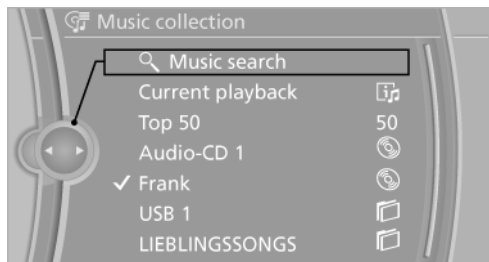

4. Select the desired category.



5. Select the desired entry:
 - ▷ Select "A-Z search", see page 19, and make the desired entry.
 - ▷ Select the desired entry from the list.
6. Select further categories as appropriate. The tracks found are listed in alphabetical order. Not all categories need to be selected. To find, for example, all the tracks of a certain artist, only call up the artist. All tracks by that artist will be displayed.
7. "Start playback"
 - The list of tracks is repeated automatically.

Starting new music search

"New search"

Music search using voice control

Instructions for the voice control system, see page 21.

1.  Press the button on the steering wheel.
2. ›Music search‹
3. Call up the desired category, for example ›Select artist‹.
4. Say the desired entry from the list.
5. Select further categories as appropriate.

Selecting the track directly: ›Title ...‹.

Say the spoken command and the name of the desired track together in one command.

Currently playing

List of tracks last generated by a music search, or the last album selected.

1. "CD/Multimedia"
2. "Music collection"
3. "Current playback"

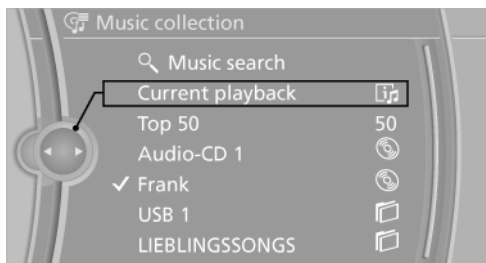

4. If applicable, select the desired track.



Top 50

The 50 most played tracks.

1. "CD/Multimedia"
2. "Music collection"
3. "Top 50"
4. If applicable, select the desired track.

Albums

All saved albums, listed in the order of the date of saving.

Symbol	Format
	Audio CD
	Compressed audio files

1. "CD/Multimedia"
2. "Music collection"
3. Select the desired album.

Depending on the album, the tracks or sub-directories of the album are displayed. The first track will be played automatically if possible.

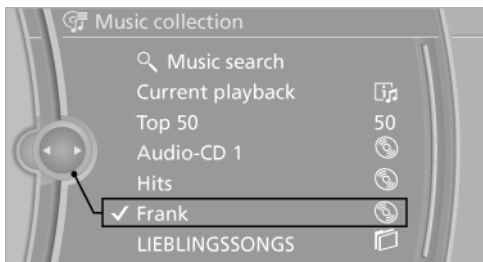

4. Change directories if necessary to select a track.

To change to a higher-level directory: tilt the controller to the left.

Random playback

All the tracks in the selection are played in random order.

1. "CD/Multimedia"
2. "Music collection"

3. Call up "Options".
4. "Random"

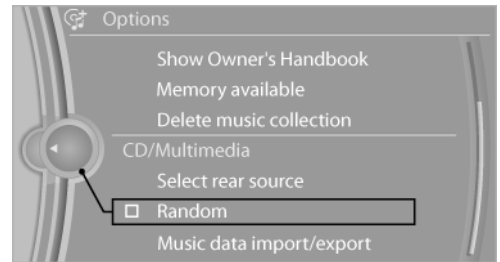

Managing music

Albums

Renaming album

If applicable, the name of the album is entered automatically during saving. If the name is unknown it can also be changed.

1. "CD/Multimedia"
2. "Music collection"
3. Highlight the desired album.
4. Call up "Options".
5. "Rename album"

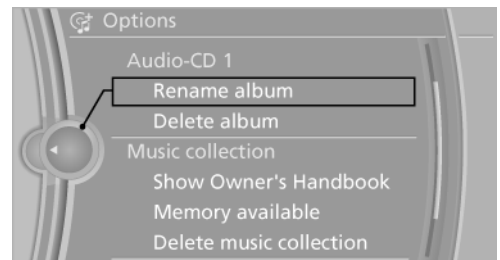

6. Select the letters individually.

Deleting album

It may not be possible to delete an album while a track from that album is being played.

1. "CD/Multimedia"
2. "Music collection"

3. Highlight the desired album.
4. Call up "Options".
5. "Delete album"

Deleting directory and track

It may not be possible to delete a track while it is being played,

or to delete a directory while a track from that directory is being played.

1. "CD/Multimedia"
2. "Music collection"
3. Highlight the directory or track.
4. Call up "Options".
5. "Delete folder" or "Delete track"

Album information

If no information was saved for audio CDs during saving, it can be updated later via BMW Online as required.

The update takes place for each individual album.

Updating album information via BMW Online

1. "CD/Multimedia"
2. "Music collection"
3. Highlight the desired album.
4. Call up "Options".
5. "Update album info online"

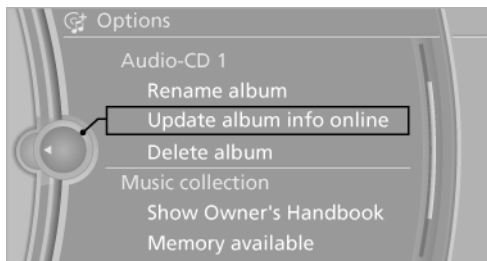

If it was possible to save the album information, the name of the album is displayed.

Free capacity

Display free capacity in the music collection.

1. "CD/Multimedia"
2. "Music collection"
3. Call up "Options".
4. "Memory available"

Music collection

Backing up music collection

The entire music collection can be backed up on a USB medium. Ensure that the USB medium has adequate free capacity.

Depending on the number of tracks, backing up the music collection can take several hours. This is why it is best to make the backup during a longer journey.

1. Starting the engine.
2. Connect the USB medium to the USB interface in the glove box.
3. "CD/Multimedia"
4. "Music collection"
5. Call up "Options".

6. "Music data import/export"

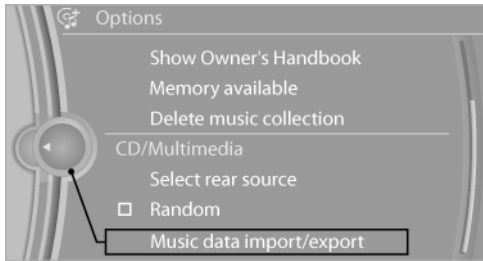

7. "Backup music on USB"

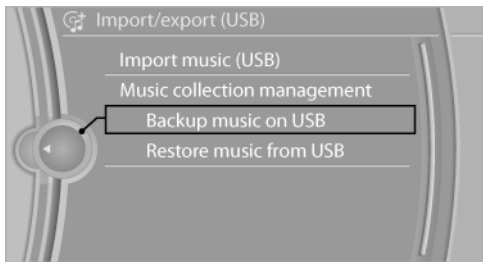

Saving music collection to the vehicle

When music is saved from a USB medium, the existing music collection in the vehicle is replaced.

1. "CD/Multimedia"
2. "Music collection"
3. Call up "Options".
4. "Music data import/export"
5. "Restore music from USB"

Deleting music collection

1. "CD/Multimedia"
2. "Music collection"
3. Call up "Options".
4. "Delete music collection"

External devices

Overview

Symbol	Meaning
	AUX-IN port
	USB audio interface
	Audio interface for mobile phone
	Bluetooth audio

AUX-IN port

Overview

- ▶ Connection of audio devices is possible, for example MP3 players. The sound output is via the vehicle loudspeakers.
- ▶ Recommendation: medium sound and volume settings on the audio device. The sound might depend on the quality of the audio files.

Connecting

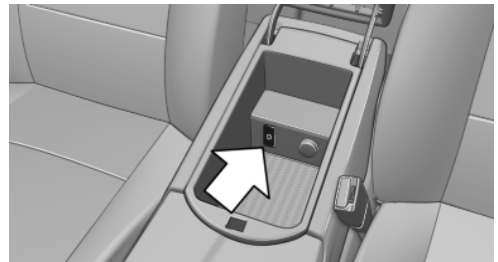

AUX-IN port is in the centre console.

Connect the headphones or line-out connection of the equipment to the jack connector.

Playback

1. Connect the audio device, switch it on and select a track.
2. "CD/Multimedia"
3. If applicable, "External devices"
4. "AUX front"

The sound is output via the vehicle loudspeakers.

Volume control

The volume of the sound output depends on the audio device. If this volume differs significantly from other audio sources, it makes sense to balance the volumes.

Adjust volume

1. "CD/Multimedia"
2. If applicable, "External devices"
3.  "AUX front"
4. "Volume"

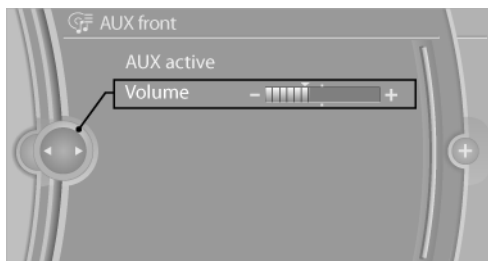

5. Turn the controller until the desired volume setting is reached and press the controller.

USB audio interface /mobile phone audio interface

Overview

External audio devices can be connected, Operation is done using the iDrive. The sound output is via the vehicle loudspeakers.

Connection options for external devices

- ▷ Connection is via USB audio interface: Apple iPod/iPhone, USB devices, for example MP3 player, USB memory sticks or mobile phones that are supported by the USB audio interface.
- ▷ Connection is via snap-in adapter if your vehicle is equipped with extended connectivity

of the music player in the mobile phone: Apple iPhone or mobile phones.

Playback is only possible if no audio device is connected to the AUX-IN port.

Due to the large variety of the audio devices available on the market, operation using the vehicle cannot be ensured for every audio device/mobile phone.

Ask at your Service centre regarding suitable audio devices/mobile phones.

Audio files

Playback of common audio files is possible:

- ▷ MP3.
- ▷ WMA.
- ▷ WAV (PCM).
- ▷ AAC, M4A.
- ▷ Playback lists: M3U, WPL, PLS.

File systems

Current file systems for USB devices are supported. FAT 32 format is recommended.

Connection of Apple iPod/iPhone via USB audio interface

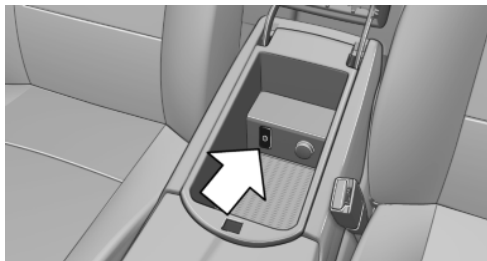

The USB audio interface is in the centre armrest. For the connection, use the special cable adapter for the Apple iPod/iPhone, available from the Service centre, or a flexible adapter cable.



Connect the Apple iPod/iPhone to the AUX-IN port and USB interface using the special cable adapter or to the USB interface using the flexible adapter cable.

The menu structure of the Apple iPod/iPhone is supported by the USB audio interface.

Connection of USB device via USB audio interface

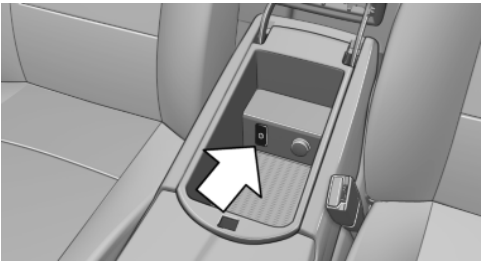

The USB audio interface is in the centre armrest. Connect using the flexible adapter cable. This protects the USB interface and your USB device against mechanical damage.



Connect the USB device to the USB interface.

After connecting for the first time

Information on all titles, e.g. interpretation on type of music, as well as the playback lists are transferred to the vehicle. This might take some time, depending on the USB device and the number of tracks.

During transfer, the tracks can be called up via the file directory.

Number of tracks



Information on up to four USB devices or for approximately 16000 or 36000 titles can be stored in the vehicle. If a fifth device is connected or more than 16000 or 36000 tracks are saved, the

information from existing tracks will be deleted if required.

Copy protection

Music tracks with integrated Digital Rights Management (DRM) cannot be played.

Playback

1. "CD/Multimedia"
2. "External devices"
3. Select the  or  symbol.



Playing starts with the first track.

In the split-screen view, split-screen, after a few seconds, the CD cover belonging to the title is displayed.



Searching for tracks

Options via:

- ▷ Playlists
- ▷ Information: type of music, interpretation, if necessary composer, album, track.
- ▷ Additionally for USB devices: file directory, composer if necessary.

The titles are displayed if they have been created with Roman letters.

Starting the track search

1. "CD/Multimedia"
2. "External devices"
3. Select the  or  symbol.
4.  "Search"

5. Select the desired category, for example "Genre" or "Artist".

All entries are shown in a list.

- ▶ Call up "A-Z search" and make the desired entry. When you enter a character, a filter is run on the basis of this character as the first letter. When you enter several characters, all the results that contain this character string are displayed.
- ▶ Select the desired entry from the list.

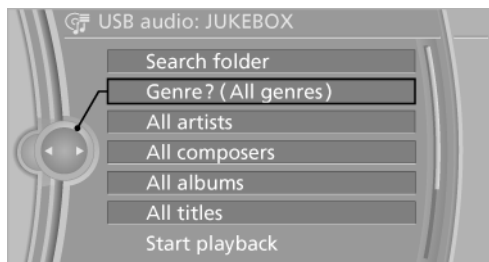



6. Select further categories as appropriate. Not all categories need to be selected. If, for example, all the tracks of a certain artist are to be displayed, it is sufficient to call up only this artist. All tracks by that artist will be displayed.
7. "Start playback"

Starting a new track search

"New search"



Playlists

Calling up playlists.

1. "CD/Multimedia"
2. "External devices"
3. Select the  or  symbol.
4.  "Playlists"

Currently playing

List of currently played tracks.

1. "CD/Multimedia"
2. "External devices"
3. Select the  or  symbol.
4.  "Current playback"

Random playback

The current list of tracks is played in random order.

1. "CD/Multimedia"
2. "External devices"
3. Call up "Options".
4. "Random"

Fast forward/rewind



Keep button pressed.



Video playback

Overview



Video playback possible through snap-in adapter. Operation is done using the iDrive. The sound output is via the vehicle loudspeakers.

Playback

The video image is shown on the front control display up to a speed of approximately 3 km/h, 2 mph. In some countries, it is only shown with the parking brake engaged or in gear position P.

1. "CD/Multimedia"
2. "External devices"
3.  Select the symbol.
4.  "Video"
5. Select the directory as appropriate. To change to a higher-level directory: tilt the controller to the left.
6. Select the desired video file to start playback.

Video menu

Symbol	Function
	Next video file
	Previous video file Select symbol twice to play back the previous video file.

Notes

Do not expose the audio device to extreme environmental conditions, for example very high temperatures, see the operating instructions of the audio device.

Depending on the format of the audio files perfect playback cannot be ensured in every case; for example bit rates higher than 256 Kbit/s.

Notes on connecting

- ▶ The connected audio device is supplied with a maximum of 500 mA if the device supports this. Do not, therefore, also connect the device to a socket in the vehicle as otherwise perfect playback cannot be guaranteed.
- ▶ Do not insert the plug forcibly in the USB interface.
- ▶ Do not connect any devices such as fans or lights to the USB audio interface.
- ▶ Do not connect up USB hard drives.
- ▶ Do not use the USB audio interface for charging external devices.

Bluetooth audio

Overview

- ▶ Playback of music files from external devices such as audio devices or mobile phones via Bluetooth is possible.
Using a mobile phone as an audio source, see page 210.
- ▶ The sound output is via the vehicle loudspeakers.

- ▶ The volume of the sound output depends on the device. If applicable, change volume settings on the device.
- ▶ Up to four external devices can be registered with the vehicle.

Requirements

- ▶ Suitable device. Visit www.bmw.com/bluetooth for more information.
- ▶ Device ready for operation.
- ▶ Ignition switched on.
- ▶ Bluetooth in the vehicle, see page 209, and device activated.
- ▶ Bluetooth presettings must be made on the device, for example connect without confirmation or visibility, see Owner's Handbook of the device.
- ▶ A number with a minimum of 4 and a maximum 16 positions is specified as the Bluetooth passkey. Only required for non-recurring registration.

Connecting



Connecting the device

Only connect the device when the vehicle is stationary. Otherwise, you may become distracted and endanger the vehicle occupants and other road users. ◀

1. "CD/Multimedia"
2. "Bluetooth (audio)"
3. If applicable, "Bluetooth audio"
4. "Add new device"

The Bluetooth name of the vehicle is displayed.



- To perform other operations on the device; see the Owner's Handbook of the device: for example finding/connecting Bluetooth device or new device.

The Bluetooth name of the vehicle is shown on the display of the device.

- Select the Bluetooth name of the vehicle on the display of the device.

There is a request via iDrive or the device to enter the same Bluetooth passkey.

- Enter and confirm passkey.

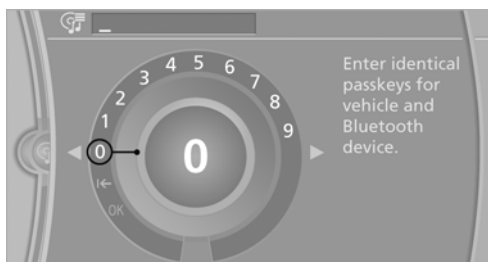

- Select the desired functions to which the device is to be connected, for example "Audio".
- "OK"

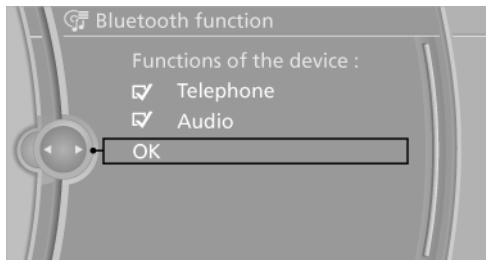

If connection was successful, the device is shown as connected.

🎵 White symbol: device active as audio source.

If connection was unsuccessful: What to do if..., see page 200.

Connecting a certain device

An already connected device can be connected as an active audio source.

Connection not possible if data is exchanged using a mobile phone equipped with Bluetooth.

Requirements

If necessary, activate the audio connection of the desired device from the list of connected devices.

- "CD/Multimedia"
- "Bluetooth (audio)"
- If applicable, "Bluetooth audio"
- Select desired device from list of registered devices.
- Call up "Options".
- "Configure device"
- "Audio"
- "OK"

Connecting a device

1. "CD/Multimedia"
2. "Bluetooth (audio)"
3. If applicable, "Bluetooth audio"
4. Select desired device from list of registered devices.



♪ White symbol: device active as audio source.

Playback

General

- Displaying title information depends on the device.
- Can be operated using the device or iDrive.
- Playback is interrupted if data is exchanged using a mobile phone equipped with Bluetooth.

Starting play

1. Connecting a device.
2. "CD/Multimedia"
3. "External devices"
4. Select the symbol.

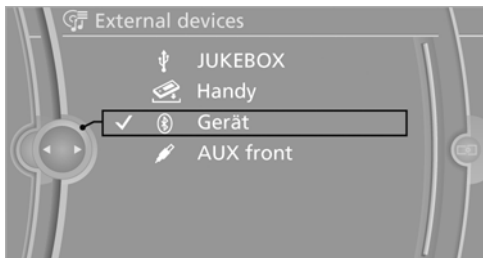

5. Select the desired track from the list.

Playback menu

Not all functions may be available, depending on the device.

Symbol	Function
	Next track Fast forward: keep symbol pressed.
	Previous title Rewind: keep symbol pressed.

Searching for tracks

A title search is possible depending on the device.

1. "CD/Multimedia"
2. "External devices"
3. Select the symbol.
4. "Search device content"
5. "A-Z search"
 - Select desired entry or directory.

Playback programmes

Depending on the device, different programs for playing back the music files are available.

1. "CD/Multimedia"
2. "External devices"
3. Select the symbol.
4. Call up "Options".
5. "Select player"
6. Select the desired channel.

Disconnecting audio connection

1. "CD/Multimedia"
2. "Bluetooth (audio)"
3. Highlight the desired device.
4. Call up "Options".

5. "Configure device"

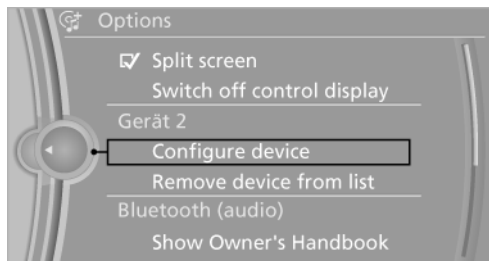

6. "Audio"

7. "OK"

Disconnecting a device

1. "CD/Multimedia"
2. "Bluetooth (audio)"
3. If applicable, "Bluetooth audio"
4. Highlight the device to be disconnected.
5. Call up "Options".
6. "Remove device from list"

What to do if...

Visit www.bmw.com/bluetooth for more information on compatible devices.

Compatible mobile phones, see page [208](#)

Device not supported by the vehicle.

- ▷ If applicable, perform a software update, see page [200](#).

Device not registered or paired.

- ▷ Do the Bluetooth passkeys for device and vehicle match. Enter the same passkey on the device and using iDrive.
- ▷ Duration for passkey input longer than 30 seconds. Repeat the connection attempt.
- ▷ Too many Bluetooth devices paired to the device or the vehicle? If necessary delete the pairing information for some other device.
- ▷ Is the mobile phone in power-save mode or is the battery low? Charge the mobile phone

using the snap-in adapter or the charging cable.

- ▷ If appropriate, only one device can be connected to the vehicle, depending on the mobile phone. De-register the device from the vehicle and only register and connect one device.
- ▷ Is the device no longer responding. Switch the device off and on again.
- ▷ Repeat the connection attempt.

No music can be played back.

- ▷ Start the program for playing back music files on the device and if necessary, select a track via the device.
- ▷ Switch the radio off and on again.

Music files are played back, but only at low volume.

- ▷ Adjust the volume controls on the device.

Playback is disrupted when a button is pressed on the device or if other messages are issued via the device.

- ▷ Switch off keypad acknowledgement tones and other audio output at the device.

Playback is interrupted by phone calls or traffic announcements and does not resume automatically.

- ▷ Switch the radio off and on again.

Playback not possible if the mobile phone is connected via both Bluetooth Audio and the extended connectivity of the music player in the mobile phone option.

- ▷ Disconnect one of the two pairing connections, for example disconnect audio connection, see page [199](#), and restart playback.

If all the points on the list have been reviewed and the desired function cannot be run, contact Hotline or Service Centre.

Software update

Depending on the current software, the vehicle supports different external devices. A software update may be supported, for example, by a new

mobile phone or new external devices of the vehicle.

The software is updated via:

► USB.

Updates and related, up-to-date information is available on the website www.bmw.com/update.

► BMW TeleServices

The available software can be updated directly through the vehicle.

Show current version

The information about the version of the software currently installed is displayed.

1. "Settings"
2. "Software update"
3. "Show current version"

Select desired version to display additional information.

Update software via USB

Do not attempt to update the software unless the vehicle is at a standstill.

1. Store the file for the software update onto a USB data store in the main folder.
2. Connect the USB storage device to the USB interface of the USB audio interface in the centre arm rest. Updating via the USB interface in the glove box is not possible.
3. "Settings"
4. "Software update"
5. "Update software"

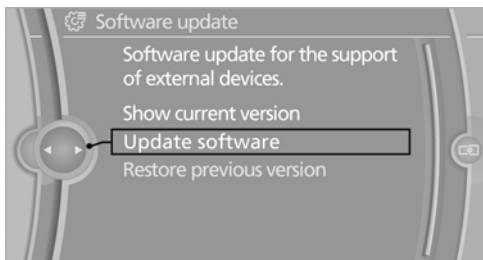

6. If applicable, "USB"
7. "Start update"
8. "OK"

All the updates listed are installed.

Update software via BMW TeleServices

Do not attempt to update the software unless the vehicle is at a standstill.

1. Switch on ignition.
2. "Settings"
3. "Software update"
4. "Update software"
5. "BMW TeleServices"
6. If applicable, "Start update"
7. "Start update"
8. "OK"

All the updates listed are installed.

To interrupt update: "Cancel!".

Restore previous version

The software version before the last software update can be restored.

Do not attempt to restore the previous version of the software unless the vehicle is at a standstill.

1. "Settings"
2. "Software update"
3. "Restore previous version"
4. "OK" select twice.

All the updates listed are removed.

Note

During a software update or when restoring the previous version, BMW Services, Office functions and associated devices are not available for a short time. Wait a few minutes until availability is restored.

Television, TV



General

For your own safety, the TV picture is only displayed up to approx. 3 km/h. On some national versions, it is only displayed when the parking brake is engaged or gear position P is engaged.

Selecting program

All receivable analogue and digital TV channels as well as digital radio stations appear in a list. The radio stations are shown at the end of the list.

In certain circumstances, the list of channels that can be received might not be updated automatically. Update the list with station search, see page 202, if necessary.

Symbol	Meaning
	Digital TV channels.
No symbol	Analogue TV channels.
	Digital radio stations.

1. "CD/Multimedia"
2. "TV"
3.  "All programs"

The channel last seen is displayed.

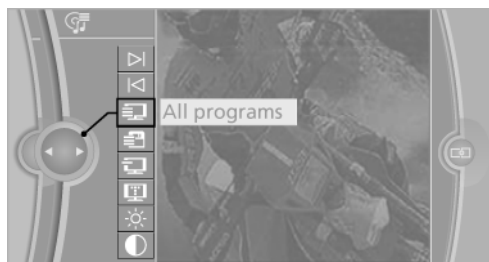

4. Select the desired channel.

The navigation bar is displayed. It is hidden after five seconds.

To show the navigation bar: press the controller.

The selected channel is saved for the remote control currently in use.

Station search



The station search takes up to 3 minutes depending on the number of channels offered. If not all offered channels are listed, it might be necessary to reset the TV standard, see page 204.

1. "CD/Multimedia"
2. "TV"
3. Call up "Options".
4. "Station search"

Cancelling the station search

"Cancel station search"

Changing the channel

1. "CD/Multimedia"
2. "TV"
3. Carry out one of the following points:
 - ▷  "Next program" or  "Previous program"
 - ▷  Press the button.
 - ▷ Turn the controller.

The next or previous programme from the last selected list of all programmes or saved programmes is displayed.

Saving the channel

1. "CD/Multimedia"
2. "TV"
3.  "All programs"
4. Select the desired channel.
5. Call up "Options".
6. "Save program"
7. Select the desired memory location.

The saved channels are stored for the remote control currently in use.

Channel information

Information on the currently selected channel. For broadcasts that are starting, information is available up to 4 hours in advance. The function must be supported by the TV channel.

1. "CD/Multimedia"
2. "TV"
3.  "Program information"



Saved channels

Twenty-five channels can be saved.

1. "CD/Multimedia"
2. "TV"
3.  "Saved programs"
4. Select the desired channel.

Deleting channels

1. "CD/Multimedia"
2. "TV"
3.  "Saved programs"
4. Highlight the channel to be deleted.
5. Call up "Options".
6. "Delete"

Adjusting TV

Brightness and contrast

1. "CD/Multimedia"
2. "TV"

3. Select the  or  symbol.

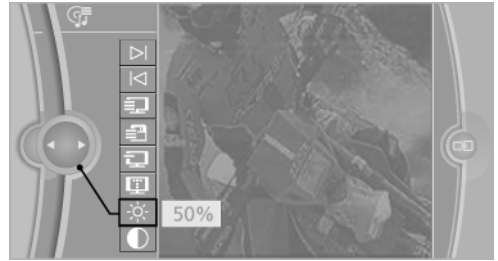

4. Turn the controller until the desired setting is reached and press the controller.

Colour

1. "CD/Multimedia"
2. "TV"
3. Call up "Options".
4. "Colour"

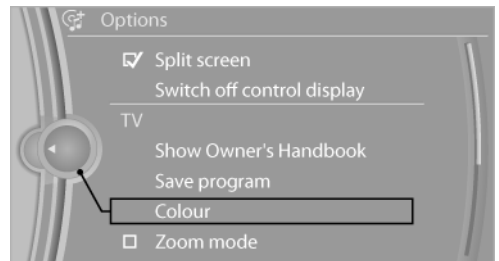

5. Adjusting: turn the controller.

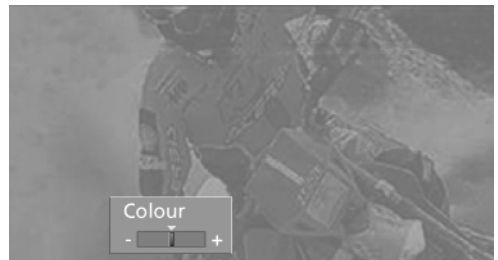

6. Saving: press the controller.

Zoom

Showing an enlarged TV image.

1. "CD/Multimedia"
2. "TV"
3. Call up "Options".
4. "Zoom mode"

Select from country list

The TV format is not the same in every country. The TV receiver can be adjusted to all common formats. Select the desired region.

1. "CD/Multimedia"
2. "TV"
3. Call up "Options".
4. "TV standard"

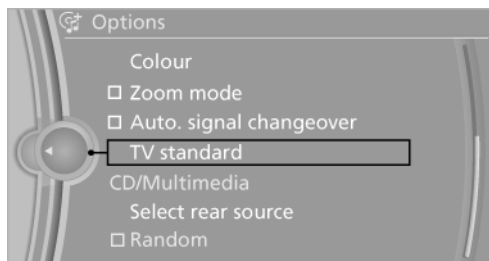

5. Select the desired region.

The setting is saved for the remote control currently in use.

Automatic analogue/digital changeover

Automatic changeover between analogue and digital reception of a station, if the digital reception is not longer possible in a region. Requirement: availability of the corresponding analogue station.

1. "CD/Multimedia"
2. "TV"
3. Select the desired station.
4. Call up "Options".
5. "Auto. signal changeover"

Selecting the audio track

The range of audio tracks available depends on the TV programme and time of day.

1. "CD/Multimedia"
2. "TV"
3. Call up "Options".
4. "Audio track"

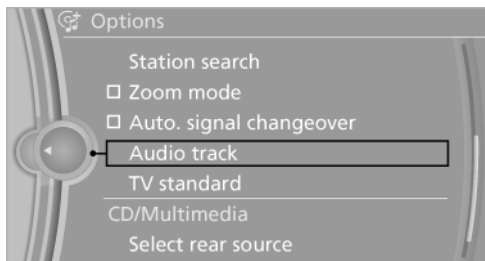

5. Select the desired audio track.

Teletext

Calling up teletext

1. "CD/Multimedia"
2. "TV"
3.  "Videotext"

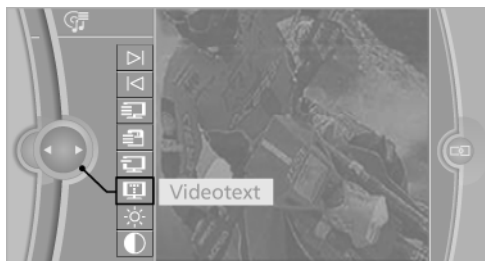

Selecting page

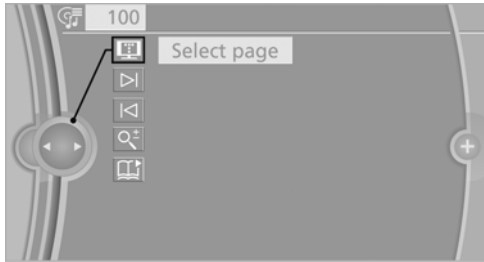

1.  "Select page"



2. Turn the controller until the desired page number is displayed.
3. Press the controller.

If the contents are too long to be shown on a single page the display is scrolled automatically.

Changing pages

Select the  or  symbol.

Zoom

The top or bottom half of the page can be enlarged.

Highlight  "Zoom" and press repeatedly until the desired view is displayed.

Automatic scrolling

A page may consist of several sub-pages which are automatically scrolled through.

To prevent scrolling: select the  symbol.

To permit scrolling: select the  symbol.



Communication

All of the possibilities available for mobile communication with your family, friends, business partners or service providers are summarised in this chapter.

Telephone

Vehicle Equipment

This chapter describes all standard, national and special equipment provided in the model series. Therefore equipment not available in a vehicle is also described, for example the selected special equipment or national version. That also applies to safety-relevant functions and systems.

Overview

Principle

Mobiles or other external devices, e.g. audio player, can be connected to the vehicle by Bluetooth.

After registering once, these devices are automatically detected when the ignition is switched on, as soon as they are in the vehicle and can be operated using iDrive, keys on the steering wheel or by voice.

External devices can be used depending on functionality of the device as a telephone or as an audio source through the vehicle. The telephone functions are described below.

Up to four external devices can be registered.

It might be necessary to have certain functions enabled by the mobile phone or service provider.

 Using the telephone while the vehicle is in motion

Only make inputs when traffic activity permits. As the driver, do not make telephone calls with the mobile phone in your hand while the vehicle is in motion; use the hands-free speaking system. The vehicle occupants and other road users could otherwise be endangered. ◀

Snap-in adapter

The snap-in adapter enables:

- ▷ Storage of the mobile phone.
- ▷ Charging of the battery.
- ▷ Connection to the external aerial of the vehicle.
This ensures better network reception and uniform reproduction quality.

Compatible mobile phones

Visit www.bmw.com/bluetooth for detailed information about the mobile phones and external devices with Bluetooth interface that are supported by the mobile phone preparation option.

Viewing vehicle identification number (VIN) and software part number

The vehicle identification number (VIN) and software part number are necessary so that you can check which mobile phones are supported by the mobile phone preparation option. You might also need details about the mobile phone's software version.

1. "Telephone"
2. Call up "Options".
3. "Bluetooth Info"
4. "Display system information"

These suitable mobile phones have a certain software version that supports the functions of the vehicle described below.

Malfunctions may occur when using other mobile phones or software versions.

Do not operate a connected mobile phone with the keypad of the phone to avoid malfunctions.

You have the option of performing a software update.

Notes

At high temperatures, the charging function of the mobile can be restricted and no longer operate.

When using the mobile through the vehicle, follow the user manual of the mobile.

Connecting/disconnecting the mobile phone

General

The following functions are available:

- ▶ Using a mobile phone as a telephone.
- ▶ Using a mobile phone as an additional telephone.
- ▶ Using a mobile phone for data transfer.
- ▶ Using a mobile phone as an audio source.
- ▶ Using an audio device as an audio source.

Requirements

- ▶ Suitable mobile phone.
- ▶ Mobile phone operational.
- ▶ Bluetooth in the vehicle and mobile phone activated.
- ▶ Bluetooth presettings must be made on the mobile phone, for example connect without confirmation or visibility; see Owner's Handbook of the device.
- ▶ If applicable deactivate Bluetooth audio.
- ▶ A number with a minimum of 4 and a maximum 16 positions has been specified as the Bluetooth passkey. Only required for non-recurring registration.
- ▶ Ignition switched on.

Activating/deactivating Bluetooth connection

Bluetooth use is not permitted everywhere. Comply with relevant local laws.

1. "Telephone"
2. Call up "Options".

3. "Bluetooth"

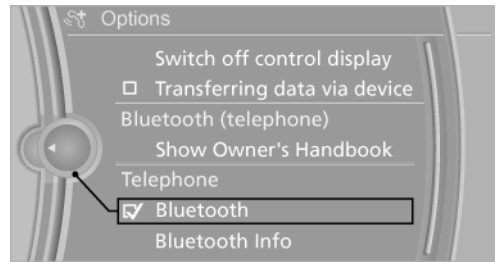

Additional functions

Enabling/disabling additional functions

Activating the functions before the registration process in order to use them in the vehicle. Information about suitable mobile phones that support these functions, see page 208.

1. "Telephone"
2. "Bluetooth (telephone)"
3. Call up "Options".
4. "Configure Bluetooth"
5. Select the desired additional function.
 - ▶ "Additional telephone"
 - ▶ "Transferring data via device"
 - ▶ "Office"
 - ▶ "Bluetooth audio"
6. "OK"

As long as the additional function is deactivated, no telephone can be assigned.

Additional telephone

A mobile phone can be used as an additional telephone.

The additional telephone can be used to accept incoming calls, see page 212. Incoming calls on the additional telephone during an active call are shown on the control display.

Data transfer

A mobile phone connected as a telephone or additional telephone can be used for data transfer. The data transfer is shown in the status line. This can result in call charges, for example, with a roaming connection.

The services breakdown assistance, Hotline, TeleService call, Automatic TeleService call and Internet are available. Using the services does not require a valid BMW Assist contract.

The availability of the function depends on the country and is series-specific. The mobile phone must be compatible with and support the required Bluetooth radio standards, equipped with a corresponding mobile tariff and have suitable Internet settings.

End data transfer

Terminating an existing data transmission immediately:

1. Call up "Options".
2. "Transferring data via device"

The additional function data transfer is deactivated and can be assigned to another mobile phone.

Audio source

A mobile phone can be used as an audio source.

Connecting



Connecting the mobile phone

Only connect the mobile phone when the vehicle is stationary. Otherwise, you may become distracted and endanger the vehicle occupants and other road users. ◀

1. "Telephone"
2. "Bluetooth (telephone)"
3. "Add new device"

The Bluetooth name of the vehicle is displayed.

4. Perform other operations on the mobile phone, see the Owner's Handbook of the

mobile phone: for example finding/connecting Bluetooth device or new device.

The Bluetooth name of the vehicle is shown on the display of the mobile phone.

5. Select the Bluetooth name of the vehicle on the display of the mobile phone.
6. Request using the iDrive or mobile phone to enter the same Bluetooth passkey. Enter and confirm passkey.

Or

Compare the control number in the vehicle display with the control number in the mobile phone display. Confirm the control number in the mobile phone and on the vehicle.

"OK"





7. Select the function for which you would like to use the mobile phone.
8. "OK"

If the registration was successful, the mobile phone is displayed at the top of the mobile phone list.

Functions supported by the mobile phone or audio device are displayed as symbols when connecting.

White symbol: function is active.

Grey symbol: function is inactive.

Symbol	Function
	Telephone.
	Additional telephone.
	Data transfer.
	Audio source.

Four mobile phones can be connected in the vehicle at the same time. Up to three mobile phones can be connected to the vehicle at the same time.

If the registration was unsuccessful: What to do if..., see page 211.

After connecting for the first time

- ▷ Mobile phone is detected/paired in the vehicle after a short delay when the engine is running or the ignition switched on.
- ▷ Phonebook entries on the telephone's SIM card or the mobile phone itself are transferred to the vehicle after it has been detected, depending on the mobile phone.
- ▷ Four mobile phones can be connected.
- ▷ For a few mobile phones, certain settings are needed, for example, authorisation or secure connection, see instruction manual of the mobile phone.

Connecting a certain mobile phone

If the vehicle detects more than one mobile phone, it connects with the mobile that is highest on the list. If necessary, another detected mobile phone can be connected with the vehicle. If another mobile phone is to be connected, this can be selected.

1. "Telephone"
2. "Bluetooth (telephone)"
3. Select the mobile phone to be connected.

Functions assigned to the mobile phone before disconnection are reassigned to the mobile phone upon reconnection. If applicable, this function was deactivated for a previously connected mobile phone.

Configuring mobile phone

Additional functions can be activated or deactivated with a registered and connected mobile phone.

1. "Telephone"
2. "Bluetooth (telephone)"
3. Highlight mobile phone to be configured.
4. Call up "Options".
5. "Configure device"
6. At least one function must be selected.
 - ▷ "Telephone"

- ▷ "Additional telephone"
- ▷ "Data transfer"
- ▷ "Audio"

7. "OK"

If a function is assigned to a mobile phone, then this is deactivated for the already connected mobile phone and the mobile phone is logged off.

Switching telephone and additional telephone

The function of the telephone and additional telephone can be switched automatically.

1. "Telephone"
2. "Bluetooth (telephone)"
3. "Change phone/addit. phone"

Disconnecting a mobile phone

1. "Telephone"
2. "Bluetooth (telephone)"
3. Highlight the mobile phone to be disconnected.
4. Call up "Options".
5. "Remove device from list"

What to do if...

Information about suitable mobile phones, see page 208.

Mobile phone not registered or paired.

- ▷ Is Bluetooth activated in the vehicle and the mobile phone? Activate Bluetooth in the vehicle and the mobile phone.
- ▷ Do the Bluetooth passkeys for the mobile phone and vehicle match. Enter the same passkey on the mobile phone and using iDrive.
- ▷ Duration for passkey input longer than 30 seconds. Repeat the connection attempt.
- ▷ Too many Bluetooth devices paired to the mobile phone or the vehicle? If necessary

delete the pairing information for some other device.

- ▷ Audio connection is activated. Deactivate audio connection.
- ▷ Is the mobile phone in power-save mode or is the battery low? Charge the mobile phone using the snap-in adapter or the charging cable.
- ▷ If appropriate, only one mobile phone can be connected to the vehicle, depending on the mobile phone. De-register the mobile phone from the vehicle and only register and connect one mobile phone.

The mobile phone is no longer responding.

- ▷ Switch the mobile phone off and on again.
- ▷ Too high or low ambient temperatures? Do not subject the mobile phone to extreme ambient conditions.

Telephone functions not possible.

- ▷ Mobile phone registered as additional telephone and additional telephone function disabled? Enable function.
- ▷ Outgoing call not possible? Connect mobile phone as telephone.

No phone book entries, not all entries or incomplete entries are displayed.

- ▷ Transfer of the phone book entries has not completed.
- ▷ Under certain circumstances only the phone book entries saved in the mobile phone or on the SIM card are transferred.
- ▷ It might be that phone book entries with special characters cannot be displayed.
- ▷ Number of phone book entries to be stored is too high.
- ▷ Data volume of the contact too large, e.g. due to stored information such as notes? Reduce data volume of the contact.
- ▷ Mobile phone connected as audio source? Mobile phone must be connected as telephone.

- ▷ Mobile phone connected as audio source or additional telephone? Mobile phone must be connected as telephone.

Quality of the phone connection is poor.

- ▷ Bluetooth signal strength can be adjusted on mobile phone, depends on the model.
- ▷ Place the mobile phone in the snap-in adapter or close to the centre console.
- ▷ Adjust the volume of the microphone and speaker separately.

If all the points on the list have been reviewed and the desired function cannot be run, contact Hotline or Service Centre.

Controls

Adjusting the volume

Turn the knob until the desired volume is reached. The setting is saved for the remote control currently in use.

The vehicle adjusts the volume of the microphone on the telephone and the volume of the other party automatically. Depending on the mobile phone, it may be necessary to adapt the volumes. Settings are possible only during a call and must be adjusted separately for each telephone. The settings are deleted as soon as the telephone is de-registered.

1. "Settings"
2. "Tone"
3. "Volume settings"
4. Select desired setting: "Microphone" or "Loudspeak."
5. Adjusting: turn the controller.
6. Saving: press the controller.

Incoming call

Receiving a call

If the number of the caller is saved in the telephone book and is transferred from the network,

the name of the contact is displayed. Otherwise, only the phone number is displayed.

If more than one phone number is assigned to the contact, only the name is displayed.

The number is only shown in the event of calls to the additional telephone, if the number is transmitted by the network.

An incoming call to the additional telephone is automatically blocked if another call is active on the other telephone.

Accepting a call

Using iDrive

 "Accept"

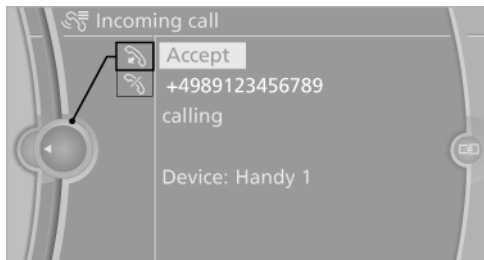

Via button on the steering wheel

 Press the button.

Via instrument cluster

"Accept"

Rejecting a call

Using iDrive

 "Reject"

Via instrument cluster

"Reject"

Ending a call

Using iDrive

 "Hang up"

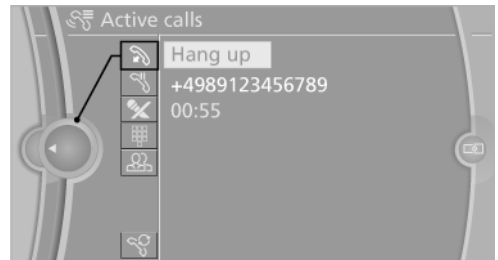

Via button on the steering wheel

 Press the button.

Via instrument cluster

"Hang up"

Entering phone numbers

Dialling a number

1. "Telephone"
2. "Dial number"
3. Select the digits individually.
4.  Select the symbol.



The phone number can also be entered using the voice control system.

Calls with a number of participants

General

It is possible to switch between calls or merge two calls to set up a conference. The functions must be supported by the mobile phone and service provider.

Accepting a call during another call

If possible, this functions must be released by the service provider and the mobile set for it.

If there is a second call during an ongoing call you hear a call waiting signal, if applicable.

 "Accept"

The call is accepted and the existing call is held.

Setting up a second call

Set up another call during a call.

1. "Telephone"
2. "Active calls"
3.  "Hold"

The current call is held.

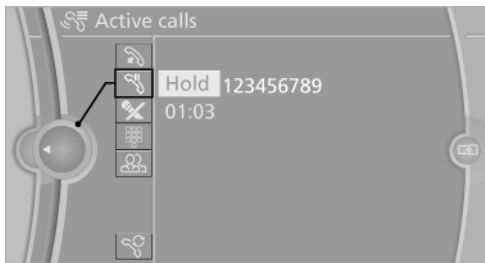

4. Dial a new phone number or select from a list.

Switching between two calls, alternating

Active call is displayed in colour.

Call on hold is displayed in grey.

 "Swap calls"

The phone switches to the call that is in progress.

Setting up a conference

Two calls can be merged to set up a telephone conference.

1. Setting up two calls.
2.  "Conference call"

On termination, both calls are always terminated. If one call is terminated by another subscriber, the other call is continued, if required.

Setting the microphone to mute

The microphone can be muted during active calls.

1. "Telephone"
2. "Active calls"
3.  "Microphone muted"

The mute microphone is automatically activated:

- ▷ When a new call is set up.
- ▷ When alternating between call parties.

DTMF overlap dialling

Using DTMF overlap dialling to access network services or to control devices, e.g. remote answer phone access. This requires the DTMF code.

1. "Telephone"
2. Selecting a contact from a list or "Dial number".
3.  "DTMF suffix dialling"
4. Enter DTMF code via iDrive.

Phone book

Displays

The phone book accesses the contacts and lists all contacts for which a phone number has been entered. The entries can be selected and a call set up.

1. "Telephone"
2. "Phone book"

A symbol indicates the storage location of the contacts.

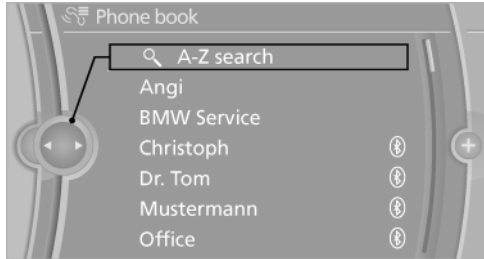

Call contact

Symbol	Meaning
	Contact with a stored telephone number.
	Contact with more than one stored telephone number.
	Call not possible, mobile phone without reception or network or Teleservice Call active.

For contacts with more than one stored telephone number: select the desired contact. The connection is established.

For contacts with more than one stored telephone number: select the desired contact and then select the phone number. The connection is established.

Editing contacts

Changing the entries in the "Contacts" menu. If a contact is changed, the changes are not saved on the mobile phone. A copy of the entry is saved in the vehicle.

1. Highlight the contact.
2. Call up "Options".
3. "Edit entry"

The contact can be edited.

Redialling

General

The list of numbers dialled in the mobile phone is transferred to the vehicle, depending on the mobile phone. The last 20 numbers dialled are displayed. The sort sequence varies from mobile phone to mobile phone.

Dialling numbers via the instrument cluster

Possible if no call is currently active.

1. Press key on the steering wheel.
2. Select the desired phone number.

The connection is established.

Dial number using iDrive

1. "Telephone"
2. "Last number redial"

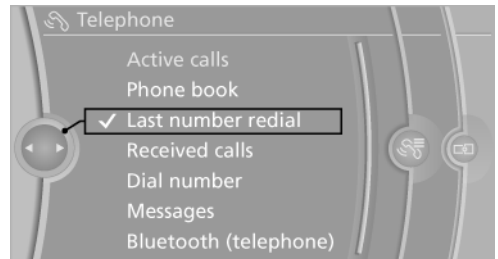

3. Select the desired entry and telephone number as necessary.

The connection is established.

Deleting an individual entry or all entries

Deletion of entries depends on the mobile phone.

1. Mark entry.
2. Call up "Options".
3. "Delete entry" or "Delete list"

Saving an entry in Contacts

1. Mark entry.
2. Call up "Options".
3. "Save as new contact" or "Add to existing contact"
4. If necessary, select contact.
5. Select the type of number: "Home", "Work", "Mobile" or "Others"
6. If necessary, complete the entries.
7. "Save contact"

Incoming calls

Displaying calls

The list of incoming calls on the mobile phone is transferred to the vehicle, depending on the mobile phone. The last 20 incoming calls are displayed. The sort sequence and the way in which numbers are displayed vary from mobile phone to mobile phone.

1. "Telephone"
2. "Received calls"

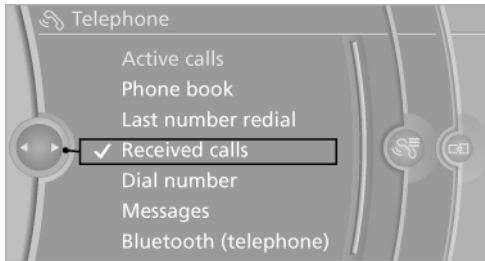

Calling a number from the list

Select an entry.

The connection is established.

Deleting an individual entry or all entries

Deletion of entries depends on the mobile phone.

1. Mark entry.

2. Call up "Options".
3. "Delete entry" or "Delete list"

Saving an entry in Contacts

1. Mark entry.
2. Call up "Options".
3. "Save as new contact" or "Add to existing contact"
4. If necessary, select contact.
5. Select the type of number: "Home", "Work", "Mobile" or "Others"
6. If necessary, complete the entries.
7. "Save contact"

Hands-free system

General

Calls taken via the hands-free system can be continued via the mobile phone and vice versa.

From mobile phone to the hands-free system

Calls that were started outside the Bluetooth range of the vehicle can be continued via the hands-free system when the ignition is switched on.

Depending in the mobile phone, there is an automatic switch to the hands-free mode.

If it is not automatically toggled, follow what is displayed on the mobile phone screen, and also see the instruction manual for the mobile phone.

From the hands-free system to the mobile phone

Calls taken via the hands-free system can also be continued via the mobile phone, depending on the mobile phone.

Then follow what is displayed on the mobile phone, and also see the instruction manual of the mobile phone.

Snap-in adapter

General

More detailed information on the snap-in adapters, which compatibly support the functions of the mobile, can be obtained from the Service centre.

Notes

At high temperatures, the charging functions of the mobile can be restricted and no longer operate.

When using the mobile through the vehicle, follow the user manual of the mobile.

Installed position

In the centre armrest.

Inserting the snap-in adapter

1. Press the button and take out the cover.

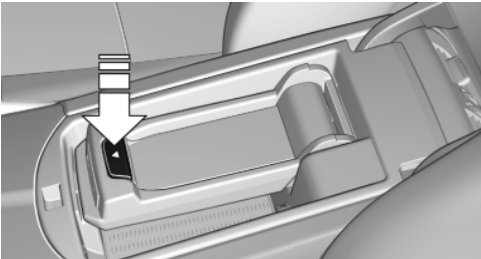

2. Insert snap-in adapter in the direction of arrow 1, and press down, arrow 2, until the adapter engages.

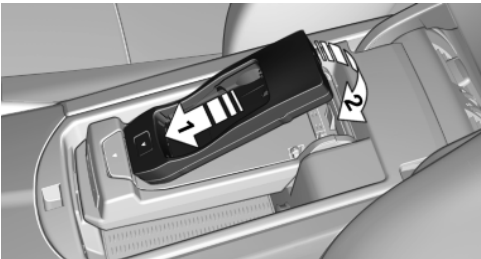

Inserting the mobile phone

1. Depending on the mobile phone, remove the protective cap from the aerial connector and from the USB port of the mobile phone if necessary.
2. Push the mobile phone with buttons upwards in the direction of the electrical connections, arrow 1, and push down, arrow 2, until it engages.

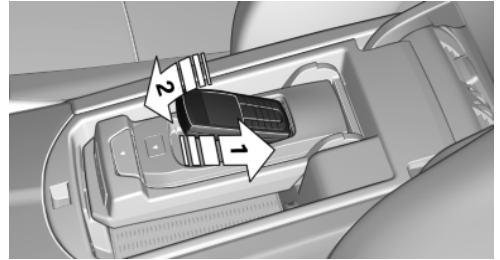

Removing the mobile phone

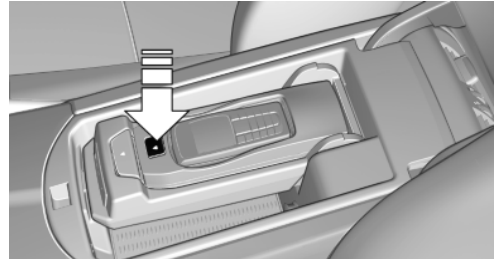

Press the button and pick up the mobile phone.

Office

Vehicle Equipment

This chapter describes all standard, national and special equipment provided in the model series. Therefore equipment not available in a vehicle is also described, for example the selected special equipment or national version. That also applies to safety-relevant functions and systems.

Overview

General

Contacts, appointments, tasks, notes, text messages and e-mails from the mobile phone can be viewed on the control display if the mobile phone supports these functions and is compatible with the corresponding Bluetooth standards.

Information on which mobile phones support which Office functions can be found under www.bmw.com/bluetooth.

Contents are completely displayed when the vehicle is at standstill.

The system can only read from the mobile.

 Do not operate Office while the vehicle is in motion.

Only make adjustments if the traffic conditions are appropriate. Otherwise, you may become distracted and endanger the vehicle occupants and other road users. ◀

Requirements

- ▶ A compatible mobile phone is registered and connected to the vehicle. For some mobile phones, data access must be confirmed on the mobile phone.
- ▶ Time, time zone and date, see page 83, are correctly set on the Control Display and on the mobile phone, for example to display appointments correctly.

- ▶ Office is activated, see page 209.

Updating

The data is updated every time the mobile phone is connected to the vehicle. Appointments, tasks, notes and reminders can be updated separately.

1. "Office"
2. "Office today", "Calendar", "Tasks", "Notes" or "Reminders"
3. Call up "Options".
4. "Update data"

Data from the mobile phone is transferred to the vehicle again.

Office update

The number of unread messages and active tasks as well as appointments coming up are displayed.

1. "Office"
2. "Office today"
3. Select the desired entry to display details.

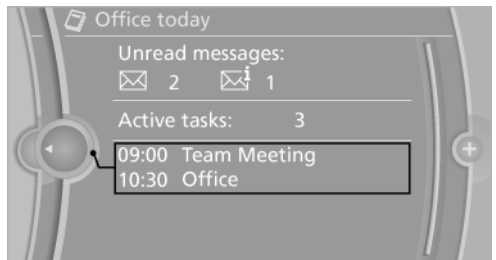

Contacts

Note

When equipped with mobile phone preparation.

Overview

Contacts can be created and edited. Contacts from the mobile phone are displayed if the mobile phone supports this function. Contacts from the BMW Online address book are also displayed. The addresses can be used as navigation destinations and the phone numbers dialed directly.

Displaying contacts

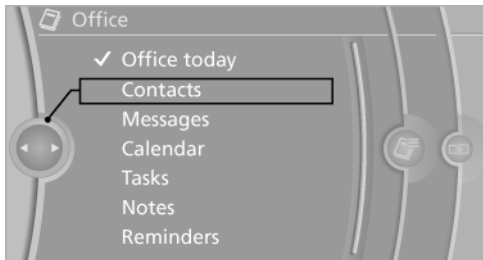

General

1. "Office"
2. "Contacts"



All contacts are listed in alphabetical order. The A-Z search, see page 19, function is offered, depending on the number of contacts.

A symbol indicates the storage location of the contacts:

Symbol	Storage location
No symbol	In the vehicle, address not checked as destination.
	In the vehicle, address checked as destination.
	Mobile phone.
	BMW Online address book.

Displaying contacts from BMW Online

To display contacts from BMW Online, when logging on to BMW Online, see page 233, the function "Login automatically" must be enabled.

Dial a phone number

1. Select the desired contact.
2. Select the phone number.
The connection is established.

Editing contacts

1. Select the desired contact.
2. "Edit contact"

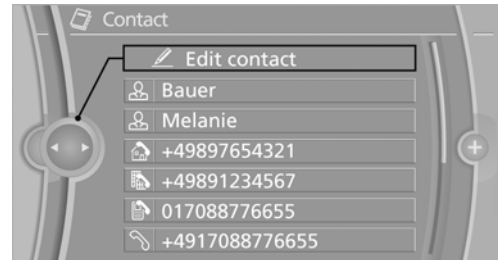

3. Change entries.
4. "Save contact in car"

If a contact that comes from the mobile phone or BMW Online is edited, the changes are not saved on the mobile phone or at BMW Online. A copy of the entry is saved in the vehicle.

Selecting a contact as navigation destination

1. Select the desired contact.
2. Select address.

In the case of contacts from the mobile phone and BMW Online address book, the address might have to be matched to the navigation data in the vehicle. If that is the case:

Correct the address.

3. "Start guidance" or "Add as another destination"

Checking address as destination

An address that is to be added to the route guidance must match the navigation data contained

in the vehicle. Here, the address can be checked.

1. Select the desired contact and highlight the address.
2. Call up "Options".
3. "Check as destination"
4. If necessary, correct and save the address.

If the address is corrected and saved, a copy is created in the vehicle. The address is not changed on the mobile phone or at BMW Online.

Display the Internet address of a contact

The Internet address stored for a contact can be called up.

1. Select the desired contact.
2. Select Internet address.

The selected Internet address is displayed in the browser.

Displaying additional information from BMW Online

Display of additional information for a contact if present at BMW Online.

1. Select the desired contact.
2. Call up "Options".
3. "Further info (BMW Online)"

New contact

General

You can add up to 8 phone numbers, 2 addresses, 3 e-mail addresses and one URL.

1. "Office"
2. "Contacts"
3. Call up "Options".

4. "New contact"

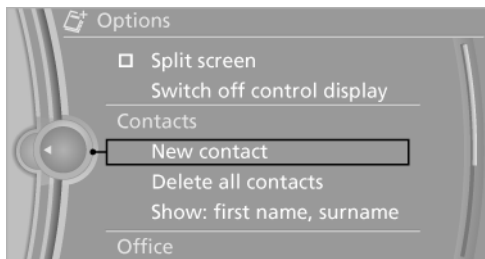

5. Input boxes still show previous input: "Clear fields"
6. To complete the input fields: select the symbol beside the input field.
7. Enter text and select a contact type.
8. In the navigation system: enter address. Only addresses that are present in the car's navigation data can be entered. This ensures that route guidance is possible for all addresses.
If applicable, "Accept address"
9. "Save contact in car"

Contact types

Phone numbers and addresses can be assigned to various contact types.

Symbol	Meaning
	Private phone number.
	Work phone number.
	Mobile phone number.
	Other phone number.
	Private address.
	Work address.

Specifying home address

A home address can be saved in memory. This home address appears at the top of the list of contacts.

1. "Home address"
2. Organising contacts
3. "Save contact in car"

Selecting sort order for names

Names can be displayed in a different order.

1. "Office"
2. "Contacts"
3. Call up "Options".
4. "Show: surname, first name" or "Show: first name, surname"

The sort order for names might not be the same as the selected sort order, depending on how contacts are saved on your mobile phone.

Display contact images

Photos saved for contacts are saved in the vehicle when the mobile phone is connected to the vehicle. The number of transferred images depends on the mobile phone. The mobile phone must support this function.

1. "Telephone"
2. "Bluetooth (telephone)"
3. "Options"
4. "Configure Bluetooth"
5. "Show pictures"

Displaying all contact images is activated or deactivated.

Exporting/importing contacts

Contacts can be exported and imported via Personal Profile, see page 29. The contacts stored in the vehicle are exported, not the contacts from the mobile phone or BMW Online.

Deleting contacts

Only contacts saved in the vehicle are deleted. The contacts from the mobile phone or BMW Online cannot be deleted.

1. "Office"
2. "Contacts"
3. Highlight the contact.
4. Call up "Options".
5. "Delete contact" or "Delete all contacts".
6. If applicable, "Yes"

Messages





General

The display of text messages and e-mails from the mobile phone depends on whether their transmission to the vehicle is supported by the mobile phone. It is possible that text messages and e-mails are not supported by the service provider or must be enabled separately. Transmission can take a few minutes after the first time a mobile phone is paired. Messages are only displayed when they are complete. Messages from the additional mobile phone cannot be transferred.

Displaying messages

1. "Office"
2. "Messages"

A Symbol designated the message type.

Symbol	Message type
	SMS.
	My Info
	Message from information service.
	Message from BMW information service.
	E-mail from mobile phone

Filter message list

The message list can be filtered if more than one type of message is available.

1. "Filter:"



2. Select type of message.
 - ▷ "All"
 - All messages are displayed.
 - ▷ "E-mail"
 - Only E-mails from the mobile phone are displayed.
 - ▷ "Service messages"
 - Only messages from BMW Information Service, My Info and BMW Info are displayed.
 - ▷ "SMS"
 - Only SMS messages are displayed.

Deleting messages

Messages from Information Service, My Info, BMW Info and BMW Online can be deleted.

Deleting a message:

1. "Office"
2. "Messages"
3. Select the desired message.
4. Call up "Options".
5. "Delete message"

Deleting all messages:

1. "Office"
2. "Messages"

3. Call up "Options".
4. "Delete all messages" or "Delete service messages"

SMS

Calling the sender of an SMS

1. Select the desired message.
2.  Select the symbol.

Saving the sender in Contacts

1. Highlight the desired message.
2. Call up "Options".
3. "Save as new contact" or "Add to existing contact"

Use contact data

Contact data from appointments, tasks, SMS, E-mails and notes can be stored or selected, see page [225](#).

Reading out text message

Read out text message, see page [226](#).

My Info





Replying

Send a predefined reply.

1. Select the desired message.
2. Call up "Options".
3. "Answer"

Select additional functions

Additional functions are available when a message is selected:

Symbol	Function
	"Start guidance" or "Add as another destination"
	"Call" A phone connection is established if the message contains a number.
	"Select phone number" Select the desired number from the list if the message contains more than one number. Telephone connection is set up.
	"Send e-mail (BMW Online)"
	"Open link in browser"





Message from information service



Saving an address

1. Select the desired message.
2. Call up "Options".
3. "Save contact in car"

Select additional functions

Additional functions are available when a message is selected:

Symbol	Function
	"Start guidance" or "Add as another destination"
	"Call" A phone connection is established if the message contains a number.
	"Select phone number" Select the desired number from the list if the message contains more than one number. Telephone connection is set up.
	"Send e-mail (BMW Online)"

Symbol	Function
	"Open link in browser" Call up Internet address.
	"Further information" Display additional information





BMW Info

General

Messages from BMW on service actions and news from BMW.

Select additional functions

The following functions are available when a message is selected:

Symbol	Function
	"Start guidance" or "Add as another destination"
	"Call" A phone connection is established if the message contains a number.
	"Select phone number" Select the desired number from the list if the message contains more than one number. Telephone connection is set up.
	"Open link in browser" Call up Internet address.
	"Further information" Detailed information of a message is displayed. This does not entail any costs.

E-mail

Display E-mail

1. "Office"
2. "Messages"

3. Select desired E-mail.

Display E-mail contacts

If sending and receiving party of an E-mail are transferred from the mobile phone, these are shown in the E-mail.

 "Sender/recipient"

If E-mail addresses are stored in contacts, the contact is displayed. Select contact to display details.

If E-mail addresses are not stored in contacts, only the E-mail address is displayed, if applicable.

Use contact data

Contact data from appointments, tasks, SMS, E-mails and notes can be stored or selected, see page [225](#).

Deactivate complete display

Opening an E-mail in the vehicle completely transfers it to the vehicle. This may be subject to charges.

1. "Office"
2. "Messages"
3. Call up "Options".
4. "Fully download e-mail"

Only part of the E-mail is loaded from the mobile phone into the vehicle.

Reading out e-mails

Read out E-mail, see page [226](#).

Calendar

Display calendar

Appointments in the last 20 days and the next 50 days can be displayed.

1. "Office"
2. "Calendar"

The current day's appointments are displayed.

Select calendar day

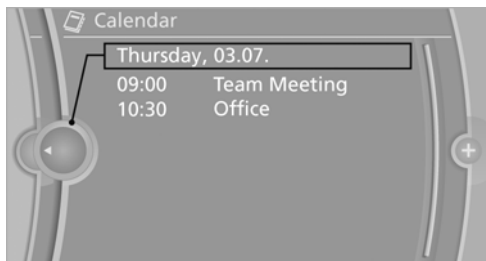

1. Select date.



2. Select desired day or date.

- ▷ "Next day"
- ▷ "Date:"
- ▷ "Day before"
- ▷ "Today"

Display appointment

1. Select the desired appointment.
2. Browse any appointments:
 - ▷ Turn the controller.
 - ▷   Select the symbol.

Use contact data

Contact data from appointments, tasks, SMS, E-mails and notes can be stored or selected, see page [225](#).

Read out appointment

Read out appointment, see page [226](#).

Tasks

Display task list

Show unfinished tasks due in the next 90 days.

1. "Office"
2. "Tasks"

Sort task list

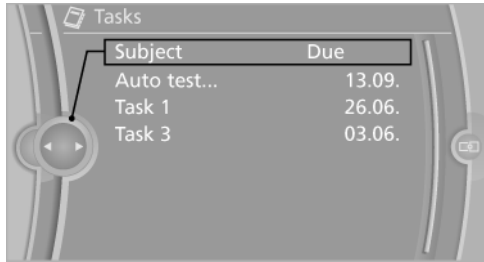

1. Select headers in the task list.



2. Select sort criterion:

- ▷ "Priority (!)"
- ▷ "Subject"
- ▷ "Due date"

Display task

1. Select the desired task.
2. Browse any tasks:
 - ▷ Turn the controller.
 - ▷   Select the symbol.

Use contact data

Contact data from appointments, tasks, SMS, E-mails and notes can be stored or selected, see page [225](#).

Read out task

Read out task, see page [226](#)

Notes

Display notes

1. "Office"
2. "Notes"



All notes are displayed.

Display note

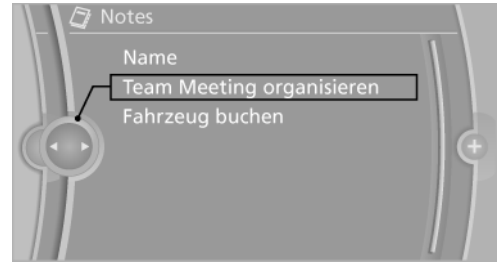
1. Select the desired note.



2. Browse any note:

- ▷ Turn the controller.
- ▷   Select the symbol

Use contact data

Contact data from appointments, tasks, SMS, E-mails and notes can be stored or selected, see page [225](#).

Read out note

Read out note, see page [226](#)

Reminders

Display reminders

Reminders connected to appointments and tasks are displayed. After an appointment or task deadline has elapsed, the reminder is no longer displayed.

1. "Office"
2. "Reminders"
3. Select the desired reminder.

The relevant appointment or task is displayed.

Use contact data

Overview

Contact data from appointments, tasks, SMS, E-mails and notes can be stored or selected.

Display contact or dial telephone number

1.  "Use contact data"
2. Display contact or dial telephone number:
 - ▷ Select contact to display a detailed view of the contact.
 - ▷ Select telephone number to make a direct connection.

Store contact data





1.  "Use contact data"
2. Highlight telephone number or e-mail address.
3. Call up "Options".
4. "Add to existing contact" or "Save as new contact"

Reading out

SMS, E-mails, appointments, tasks and notes can be read out.

1. Select desired message, appointment, task or note.
2.  Select the symbol.

The following possibilities are available when reading out:

- ▷  "Pause"
Interrupt reading out. Select again to restart reading out.
- ▷  "To beginning"
Read out message again from the beginning.
- ▷  Select the symbol.
Skip paragraph.
- ▷  Select the symbol.
Return to last paragraph.
- ▷ To end reading out, tip the controller to the left.

What to do if...

Information about suitable mobile phones, see page 208.

Appointments, tasks, notes, SMS or E-mails from the mobile phone are not displayed.

- ▷ Mobile phone is not suitable for the missing function or it is not connected correctly?
- ▷ Office function is deactivated.
- ▷ Mobile phone connected as additional telephone.
- ▷ Appointments are more than 20 days old/ more than 50 days ahead.
- ▷ Appointments are marked as done or are more than 90 days ahead.
- ▷ Not all stored appointments, tasks, notes, messages in the mobile phone are displayed in the vehicle, depending on the number of stored appointments.

Are not all appointments and task from the mobile phone displayed at the correct time?

- ▷ Time zone, time or date is not correctly set on the control display and the mobile phone.

The E-mail attachment is not displayed.

- ▷ E-mails are transferred without attachments.

Texts of entries are not fully displayed.

- ▷ Texts are abridged before they are transferred from the mobile phone.
- ▷ Synchronisation between mobile phone and vehicle might take several minutes to complete.

Contact photos are not displayed.

- ▷ A maximum of 200 contact photos can be saved in the vehicle.

Are E-mails displayed with a delay?

- ▷ Check E-mail settings on the mobile phone and adjust, if applicable.

If all the points on the list have been reviewed and the desired function cannot be run, contact Hotline or Service Centre.

Contacts

Vehicle Equipment

This chapter describes all standard, national and special equipment provided in the model series. Therefore equipment not available in a vehicle is also described, for example the selected special equipment or national version. That also applies to safety-relevant functions and systems.

Note

When equipped with Business mobile phone preparation or without mobile phone preparation.

General

Contacts can be created and edited. The contacts from the mobile phone are displayed of the mobile phone supports this function. Addresses can be used as navigation destinations and the phone numbers dialled directly.

New contact

1. "Contacts"
2. "New contact"



3. Input boxes still show previous input: "Clear fields"

4. To complete the input fields: select the symbol beside the input field.



5. Enter text, see page 19.
6. In the navigation system: enter address. Only addresses that are present in the car's navigation data can be entered. This ensures that route guidance is possible for all addresses.
7. If applicable, "Save"
8. "Save contact in car"

Specifying home address

A home address can be saved in memory. This home address appears at the top of the list of contacts.

1. "Home address"
2. Create contact.
3. "Save contact in car"

My contacts

General

List of all contacts from the vehicle and the mobile phone.

Displaying contacts

1. "Contacts"

2. "My contacts"



All contacts are listed in alphabetical order. The A-Z search, see page 19, function is offered, depending on the number of contacts.

A symbol indicates the storage location of the contacts:

Symbol	Storage location
No symbol	In the vehicle, address not checked as destination.
	In the vehicle, address checked as destination.
	Mobile phone.

Dial a phone number

1. Select the desired contact.
2. Select the phone number.
The connection is established.

Editing contacts

1. Select the desired contact.
2. "Edit contact"



3. Change entries.

4. Tilt the controller to the left.
5. "Yes"

If a contact that comes from the mobile phone is edited, the changes are not saved on the mobile phone. A copy of the entry is saved in the vehicle and only the copy is displayed. Under certain circumstances an identical contact entry is created.

Selecting a contact as navigation destination

1. Select the desired contact.
2. Select address.

In the case of contacts from the mobile phone, the address might have to be matched to the navigation data in the vehicle. If that is the case:

Correct the address.

3. "Start guidance" or "Add as another destination"

Checking address as destination

An address that is to be added to the route guidance must match the navigation data contained in the vehicle. Here, the address can be checked.

1. Select the desired contact and highlight the address.
2. Call up "Options".
3. "Check as destination"
4. If necessary, correct and save the address.

If the address is corrected and saved, a copy is created in the vehicle. The address is not changed on the mobile phone.

Selecting sort order for names

Names can be displayed in a different order.

1. "My contacts"
2. Call up "Options".
3. "Show: surname, first name" or "Show: first name, surname"

The sort order for names might not be the same as the selected sort order, depending on how contacts are saved on your mobile phone.

Exporting/importing contacts

Contacts can be exported and imported via Personal Profile, see page [29](#).

Deleting contacts

Only contacts saved in the vehicle are deleted. It is not possible to delete contacts from the mobile phone.

1. "My contacts"
2. Highlight the contact.
3. Call up "Options".
4. "Delete contact" or "Delete all contacts".

ConnectedDrive

Vehicle Equipment

This chapter describes all standard, national and special equipment provided in the model series. Therefore equipment not available in a vehicle is also described, for example the selected special equipment or national version. That also applies to safety-relevant functions and systems.

BMW Assist

General

Assist provides certain services, for example an information service.

The exact offering is country-specific. Your Service centre will be glad to answer any questions you might have.

Assist can also be used via the Internet, where additional services are available:
www.bmw.com.

During a connection to Assist, it might be that no telephone connection can be established via the mobile phone. If the mobile phone is to be used, disconnect it from the vehicle.

BMW TeleServices

General

TeleServices supports communication with the Service centre.

- ▷ Data on the servicing needs of the vehicle can be transferred directly to the Service centre. In so doing, the Service centre can initiate the work needed earlier. The workshop stay is shortened.
- ▷ In the case of a breakdown, data on the vehicle condition can be transferred to the Mobile Service. It might be that malfunctions can be remedied directly.

- ▷ The offering is country-specific.
- ▷ Connection charges can be incurred.
- ▷ Services can be limited abroad.

Requirements

- ▷ BMW Assist is activated.
If BMW Assist is not activated, a mobile phone recommended by BMW for TeleServices and configured for mobile data communication must be connected to the vehicle.
- ▷ The SIM card is enabled for free service numbers.
- ▷ There is mobile radio communications reception.
- ▷ The ignition is switched on.

Using BMW TeleServices

The TeleServices are generally activated in the vehicle.

If the TeleServices are not active, it is possible to make a call to the Mobile Service.

To continue to use it, or to deactivate the services, contact your service partner or the BMW Customer Hotline.

Information service

General

The information service provides information, for example regarding hotels, emergency chemists, etc. and provides their telephone numbers and addresses to the vehicle. Phone numbers can be called directly and addresses taken over as a destination in the navigation.

Starting the information service

1. "BMW Services" or "ConnectedDrive"

2. "Info plus"

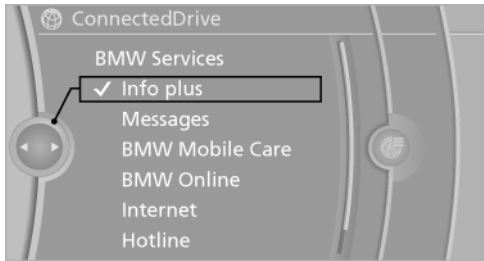

3. "Start service"

A voice connection to the BMW information service is established. Phone numbers and addresses can be transferred as messages.

Breakdown assistance

Overview

It is possible to contact the Mobile Service offered by the BMW Group if you require help in the event of a breakdown.

Contact with the Mobile Service can also be done with a Check Control Message, see page 74.

Start breakdown assistance without BMW Assist or BMW TeleServices

1. "BMW Services" or "ConnectedDrive"
2. "BMW Mobile Care"

The number for breakdown assistance is displayed. If a mobile phone is connected, a connection to breakdown assistance is established.



Start breakdown assistance with BMW Assist or BMW TeleServices

General

When equipped with BMW TeleServices, first through the BMW Teleservice diagnosis and then by the BMW Teleservice assistance, support is provided.

1. "BMW Services" or "ConnectedDrive"
2. "BMW Mobile Care"
3. "Start service"

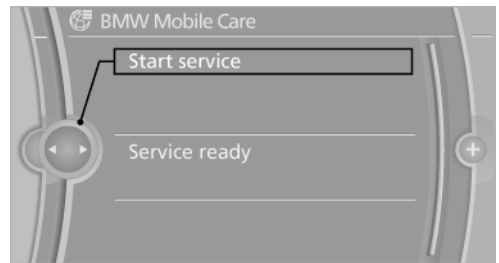

BMW Teleservice Diagnosis

Teleservice Diagnosis enables transfer of detailed vehicle data that are necessary for diagnosis of the vehicle via mobile telephony. This data is transferred automatically.

After transfer of the data, a voice connection to the Mobile Service is established.

BMW Teleservice Assistance

The Teleservice Assistance enables a deeper diagnosis of the vehicle to be gone through by the Mobile Service.

As requested by the Mobile Service and on terminating the voice connection, the Teleservice Assistance can be started.

Starting BMW Teleservice Assistance

1. Park the vehicle safely.
2. Apply the parking brake.
3. The ignition is switched on.
4. "Teleservice Help"

After concluding the Teleservice Assistance, a voice connection to the Mobile Service is established.

BMW Online

Overview

BMW Online is an online portal which provides certain services for use in the vehicle, for example information on weather forecasts, current news, stock market data, access to E-mails and personal address book.

Licensing terms

This product contains NetFront Browser Software by ACCESS Co., Ltd. Copyright © 2007 ACCESS Co., Ltd. All rights reserved.

NetFront is a trademark of ACCESS Co., Ltd. in Japan and in other countries.

This software is based in part on the work of the Independent JPEG Group.

Requirements

- ▷ BMW Online is applied for at the Service centre.
- ▷ A mobile communications network must be available.
- ▷ For certain services, for example information on current location, the vehicle must be able to determine your current location.
- ▷ The correct date is set, see page 83, on the control display.

Starting BMW Online

1. "BMW Services" or "ConnectedDrive"

2. "BMW Online"

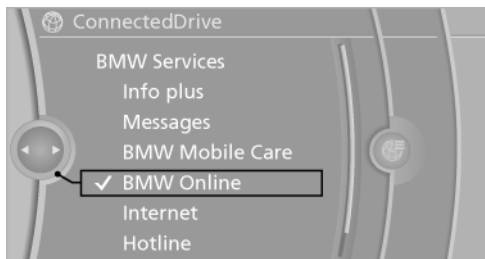

3. If applicable, "OK"

The BMW Online start page is displayed.

Using BMW Online

To select and display content:

- ▷ Turn the controller to highlight an element.
- ▷ Press the controller to display an element.

Call up home page

1. Call up "Options".
2. "Display start page"

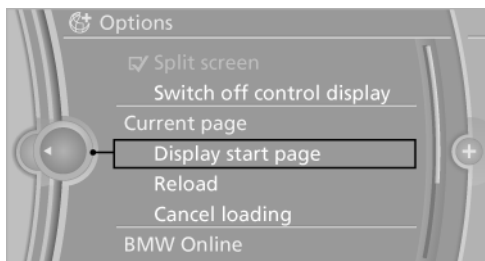

Reloading a page

1. Call up "Options".
2. "Update"

Cancel

1. Call up "Options".
2. "Cancel loading"

Log on

To display contacts of BMW Online or other personal data, log on is required.

1. "BMW Services" or "ConnectedDrive"
2. "BMW Online"
3. Call up "Options".
4. "User login"

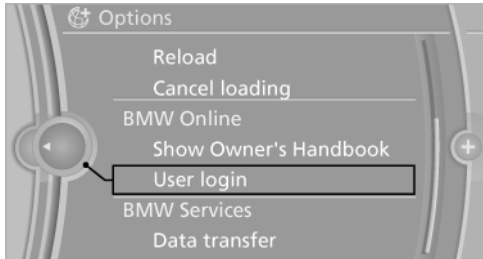

5. "User:"

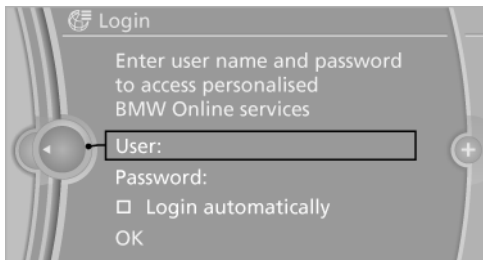

6. Enter your user name and select "OK".
7. "Password:"
8. Enter your password.
9. "OK"

Automatic log on

The log on takes place automatically when BMW Online is called up.

"Login automatically"

Logging off

1. "BMW Services" or "ConnectedDrive"
2. "BMW Online"
3. Call up "Options".
4. "User logoff"

Internet

General

For your own safety, the Internet is displayed only at up to approx. 5 km/h, 3 mph; for some national-market versions, only when the vehicle is at a standstill.

The Internet is available through the SIM card installed in the vehicle or the SIM card in the mobile phone. If the Internet is used through the SIM card in the mobile phone, follow instructions on data transmission, see page 209.

Calling up the Internet

1. "BMW Services" or "ConnectedDrive"
2. "Internet"

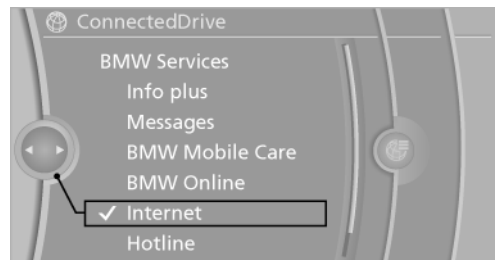

3. If applicable, "OK"

The home page is displayed. It is possible that the Internet sites are not displayed in the same way as on a PC. Flash or Java applications may be displayed incorrectly.

Licensing terms

This product contains NetFront Browser Software by ACCESS Co., Ltd. Copyright © 2007 ACCESS Co., Ltd. All rights reserved.









NetFront is a trademark of ACCESS Co., Ltd. in Japan and in other countries.

This software is based in part on the work of the Independent JPEG Group.

Operating the Internet

Menu bar

A menu bar for operation is displayed. To activate the menu bar, tilt the controller to the left until the cursor is located in the menu bar.



Symbol	Function
	Activate mouse pointer.
	Call up home page.
	Refresh, reload
	Cancel.
	Back.
	Enter URL.
	Favourites/bookmarks.
	Zoom.
	Leave browser and cut off data connection.

Navigating with the mouse pointer

-  Select the symbol.
- Navigate with the mouse pointer on the page.
 - ▶ To move the mouse pointer: tilt the controller in the corresponding direction.
 - ▶ To move the mouse pointer diagonally: tilt the controller in the corresponding direction and turn it.
 - ▶ To select an element: move the mouse pointer onto the element and press the controller.
 - ▶ To scroll: turn the controller.

Status display

A symbol in the top left on the screen indicates the following status:

Symbol	Meaning
	No connection possible.
	Data transfer/connection.
	Secure connection.

Entering Internet addresses

-  Select the symbol.
- Enter the address and select "OK".
Tilt the controller upwards to switch between upper and lower case.



Favourites/bookmarks

Add favourites

The currently displayed page is saved as a favourite.

-  Select the symbol.
- "Add to favourites"



Select favourites

-  Select the symbol.
- Select desired favourites.

Delete favourites

1. ☆ Select the symbol.
2. Highlight the favourite to be deleted.
3. Call up "Options".
4. "Delete favourite" or "Delete all favourites"

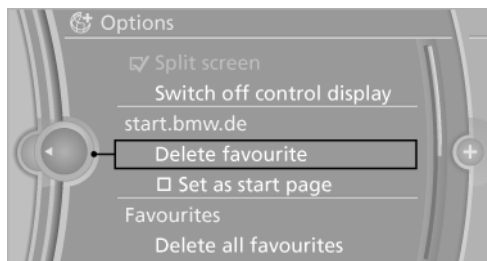

Set the favourite as home page

1. ☆ Select the symbol.
2. Highlight the desired favourite.
3. Call up "Options".
4. "Set as start page"

Settings

Suppressing cookies

1. Call up "Options".
2. "Suppress cookies"

Suppressing pop-ups

1. Call up "Options".
2. "Suppress pop-ups"

Suppressing security warnings

1. Call up "Options".
2. "Suppress HTTPS pop-ups"

Hotline

Overview

Contact the BMW Hotline for information covering every aspect of the vehicle.

Calling the hotline

Vehicle without BMW Assist or BMW TeleServices

1. "BMW Services" or "ConnectedDrive"
2. "Hotline"

The telephone number of the hotline is displayed. If a mobile phone is connected, a connection to the hotline is established.

Teleservice Call

Overview

Sends information to your service partner indicating that a service appointment is to be agreed. The Teleservice data is transferred. If possible, your service partner will establish contact with you.

Starting a Teleservice Call

1. "BMW Services" or "ConnectedDrive"
2. "Teleservice Call"
3. "Start service"



A Teleservice Call can also be started through a Check Control Message, see page 74.

Automatic Teleservice call

The Teleservice data on the service requirement for the vehicle are transmitted to your service partner automatically when a service is due. If possible, the partner will make contact and a service appointment can be agreed.

Checking when your service partner was notified:

1. "Vehicle information"
2. "Vehicle status"

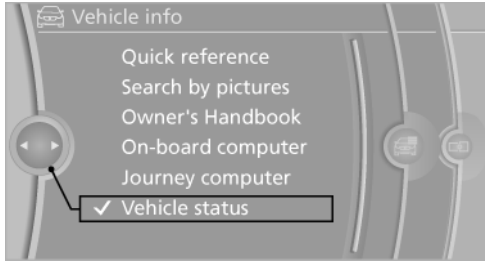

3. Call up "Options".
4. "Last Teleservice Call"

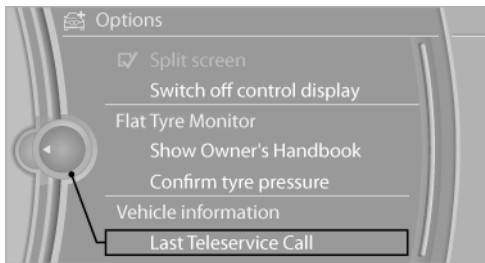

Teleservice Report

As needed, transfers the technical data from your vehicle to BMW at regular intervals. This is used to evaluate the further development of BMW products.

The Teleservice Report is activated free of charge for vehicles with certain technical requirements and with a valid Assist contract.

Neither personal information nor position data are transferred.

Displays when the last Teleservice Report has been transferred:

1. "Vehicle information"
2. "Vehicle status"

3. Call up "Options".
4. "Last Teleservice Info"

Teleservice Battery Guard

Teleservice Battery Guard constantly checks the battery charge level of the vehicle. If the battery charge level falls below a certain value, information is automatically sent to you service partner. If required, they will contact you to agree a service appointment.

Teleservice Battery Guard is only available for vehicles with certain technical prerequisites and with valid BMW ConnectedDrive contract.

Service partners

Possible contact with the Service Partner.

Displaying service partners

1. "BMW Services" or "ConnectedDrive"
2. "Your Service"

With the mobile phone registered, a connection is made to the Service Partner.

Service status

Display available services

Display of all services available in the vehicle.

1. "BMW Services" or "ConnectedDrive"
2. "Service status"
3. "Available services"

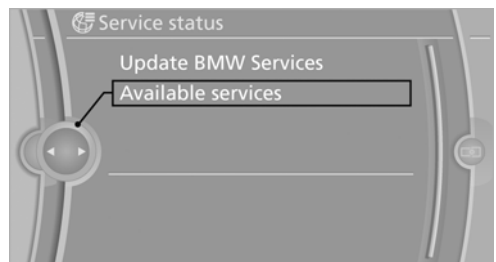

Updating BMW Services

Manually update all the services available in the vehicle.

"Update BMW Services"

Data transfer

When updating BMW services, the status of the data transfer is displayed.

1. "BMW Services" or "ConnectedDrive"
2. Call up "Options".
3. "Data transfer"

Apps

Overview

Certain software applications of a suitable mobile phone can be integrated into the vehicle. These software applications are displayed on the Control Display.

Operation is done using the iDrive.

Requirements

- ▶ Suitable mobile phone.
- ▶ The operating system of the mobile phone supports the software applications of Apps.
- ▶ Software applications are installed on operational on the mobile phone.
- ▶ Corresponding mobile radio contract.
Any additional costs incurred are not the component of Apps.
- ▶ Only use software applications approved by BMW, otherwise there may be malfunctions.

Information on suitable mobile phone, available software applications and their installation is available under www.bmw.com/connectivity or from your Service centre.



Input data

Only make inputs when traffic activity permits. The vehicle occupants and other road users could otherwise be endangered due to lack of concentration.

Some software applications can only be used when the vehicle is stationary for safety reasons. ◀

Operating Apps

1. Connect the mobile phone using the snap-in adapter or the USB audio interface.
2. "ConnectedDrive"
3. Select the desired software application.

Display status

Information on the currently available software applications can be displayed.

1. "ConnectedDrive"
2. "BMW apps"

PlugIn

Selected functions of the mobile phone are shown on the Control Display. Operation is done using the iDrive.

1. Connect the mobile phone using the snap-in adapter.
2. "ConnectedDrive"
3. "PlugIn"
4. "Activate PlugIn"
5. Using the controller, navigate in the desired functions and, for example, selected the desired category or title.



Press the button to go one level higher or back within the functions of the mobile phone.



Press button twice to change back to the main menu.

Notes

- ▷ The extent of apps which can be shown on the control display depends on the extent of software applications installed on the mobile phone.
- ▷ The data transfer of the software applications from the mobile phone to the vehicle may take a while. Some software applications are dependent on the speed of the available Internet connection of the mobile phone.
- ▷ Some mobile phones cannot use apps and Bluetooth hands-free at the same time.
Restart the software application on the mobile phone after a telephone call as necessary.

Extended BMW Online services

Vehicle Equipment

This chapter describes all standard, national and special equipment provided in the model series. Therefore equipment not available in a vehicle is also described, for example the selected special equipment or national version. That also applies to safety-relevant functions and systems.

General

The extended BMW Online services provides scope for exchanges of information and data with the vehicle via BMW Online.

The following section lists the functions of the extended BMW Online services.

Navigation

- ▷ Importing trips, see page [162](#).
- ▷ Information on points of interest from BMW Online, see page [159](#).
- ▷ Displaying current traffic regulations and country information, see page [170](#).

CD/multimedia

- ▷ Updating album information, see page [192](#).

Contacts

- ▷ Show BMW Online address book, see page [219](#).

Personal Profile

- ▷ Exporting/importing a user profile, see page [29](#).

BMW Online and Internet

- ▷ BMW Online, see page [232](#).
- ▷ Internet, see page [233](#).





Mobility

To assist you in preserving your car's mobility, this section contains important information on operating fluids, wheels and tyres, maintenance and minor repairs.

Refuelling

Vehicle Equipment

This chapter describes all standard, national and special equipment provided in the model series. Therefore equipment not available in a vehicle is also described, for example the selected special equipment or national version. That also applies to safety-relevant functions and systems.

General

Refuel in good time

If the range drops below 50 km, 30 miles, you should refuel as soon as possible, or engine function may be impaired and damage may occur. ◀

For diesel engines

The filler neck is designed for refuelling at diesel pumps.

Fuel tank cap

Opening

1. Briefly press rear edge of fuel filler flap.



2. Turn the fuel filler cap anticlockwise.

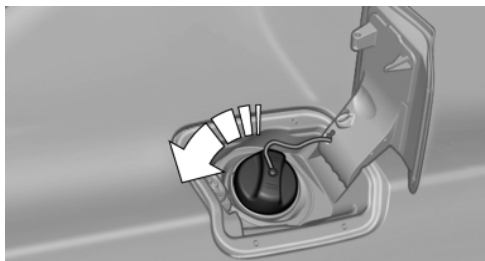

3. Place the tank cap in the holder on the fuel filler flap.

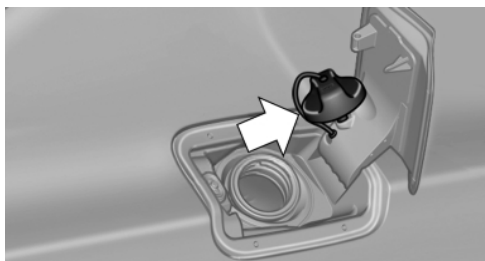

Closing

1. Fit the tank cap and turn clockwise until it is clearly heard to click into place.
2. Close fuel filler cap.



Do not crush the retaining strap

Do not jam the strap attached to the tank cap, as otherwise the tank cap cannot be closed properly and fuel vapours can escape. ◀

Unlocking fuel filler flap manually

For example in the event of an electrical fault.

1. Remove the cover from the right-hand trim panel.

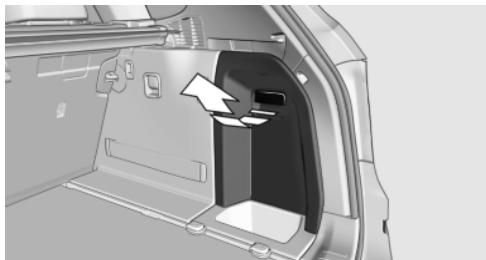

2. Pull the green tag with the fuel pump symbol. Fuel filler flap is unlocked.

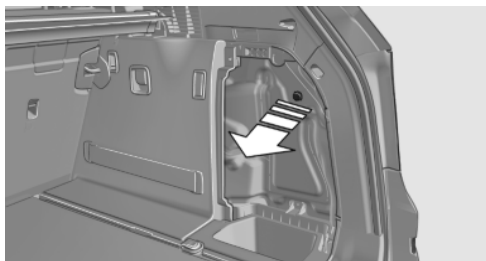



Note when refuelling

When refuelling, insert the filler nozzle fully into the filler neck. Lifting the filler nozzle during refuelling results in:

- ▷ The fuel supply being cut off prematurely.
- ▷ Fuel vapour and fumes being fed back less effectively.

The fuel tank is full when the filler nozzle cuts out for the first time.

 Do not overfill fuel tank
Do not overfill fuel tank, otherwise damage may be caused to the environment and the vehicle due to seepage of fuel. ◀

 Handling fuels
Comply with the safety regulations displayed at filling stations. ◀

Fuel

Vehicle Equipment

This chapter describes all standard, national and special equipment provided in the model series. Therefore equipment not available in a vehicle is also described, for example the selected special equipment or national version. That also applies to safety-relevant functions and systems.

Fuel grade

Petrol

For optimal fuel economy, the petrol should be sulphur-free or as low in sulphur content as possible.

Fuels labelled on the pump as containing metal must not be used.

 Only refuel with unleaded petrol without metallic additives

Do not refuel with leaded petrol or petrol with metallic additives, for example, manganese or iron, otherwise it may cause permanent damage to the catalytic converter and other components. ◀

You can fill up with fuels with a maximum proportion of ethanol of 10 %, i.e. E10.

 Do not refuel with ethanol E85
Do not use E85, i.e. fuel that consists of 85 % ethanol, or flex fuel, as otherwise the engine and fuel supply system will be damaged. ◀

Petrol grade

The engine has anti-knock control. This means that different grades of petrol can be used.

The use of Super 95 RON petrol is recommended.

Fuel qualities of 91 RON and higher are permitted.

 Minimum grade
Do not fill up with petrol below the minimum grade indicated, otherwise the engine operation is not ensured. ◀

Diesel

 Incorrect refuelling
Do not refuel any rape seed methyl ester – RME –, green diesel or petrol.

After refuelling a wrong fuel, do not start the engine, otherwise there is danger of engine damage. ◀

Contact your Service centre if the wrong type of fuel has been added.

Diesel quality

The engine is designed to run on diesel fuel to DIN EN 590.

Winter-grade diesel

 No diesel additives
Do not incorporate any additives, including petrol, as these could cause damage to the engine. ◀

Winter-grade diesel must be used to ensure reliable operation of the diesel engine during the cold season.

It is sold at filling stations over that period.

Fuel filter heating is installed as standard equipment to prevent the fuel from solidifying during operation.

BMW recommends BP fuels 

Wheels and tyres

Vehicle Equipment

This chapter describes all standard, national and special equipment provided in the model series. Therefore equipment not available in a vehicle is also described, for example the selected special equipment or national version. That also applies to safety-relevant functions and systems.

Tyre pressures

Information for your safety

A tyre's condition and pressure influence the following:

- ▷ Operating life of the tyre.
- ▷ Driving safety.
- ▷ Driving comfort.

Checking pressures



Checking tyre pressures regularly

Check regularly and adjust as necessary, but at least twice a month and before any long journey. Incorrect tyre pressures can adversely affect the car's road holding and cause tyre damage, which could result in an accident. ◀

After correcting the tyre pressure:

- ▷ Re-initialise the runflat indicator

Tyre pressure values



The inflation pressures specified for approved tyre sizes are located on the door pillar of the driver's door.

If the speed code letter for the tyre cannot be located, use the tyre pressure for the corresponding size, for example 255/50 R 19.

For Australia/New Zealand

Inflation pressures are specified on the tyre label affixed to the driver's door post.



Warning

The inflation pressures on the tyre label are applicable only for tyres explicitly mentioned on the label. Inflation pressures for tyres that may be covered by the label – by size, speed category and load rating/load index – but not explicitly mentioned on the label may be different. Please obtain adequate inflation pressures in accordance with the tyre manufacturer's specifications at your tyre dealer. ◀

Tyre sizes

Inflation pressures refer to the approved and recommended tyre sizes and tyre makes.

Your Service centre will be glad to provide more information on wheels and tyres.

Tyre tread

Summer tyres

The tyre tread depth should not be less than 3 mm, 1/8 in.

Below a tread depth of 3 mm, 1/8 in, there is a high risk of aquaplaning.

Winter tyres

The tyre tread depth should not be less than 4 mm, 3/16 in.

Below a tread depth of 4 mm, 3/16 in, suitability for vehicle operation in winter is restricted.

Minimum tread depth



Wear indicators are distributed across the tyre circumference and have the legally prescribed minimum height of 1.6 mm, 1/16 in.

They are identified on the tyre's side wall by TWI, Tread Wear Indicator.

Tyre damage

General

Inspect tyres frequently for damage, the presence of foreign bodies and wear.

Notes

Vehicle behaviour that is an indication of tyre damage or other faults:

- ▷ Unusual vibrations while the vehicle is in motion.

- ▷ Unusual vehicle response, such as pronounced pulling to the left or right.

Damage can be caused by, for example, running over kerbs, road damage etc.



In the event of tyre damage

If there are indications of tyre damage, reduce speed immediately and have the wheels and tyres checked without delay, otherwise there is an increased risk of accident.

Drive carefully to the nearest Service centre or specialist tyre dealer.

Have the car towed there if necessary.

Otherwise tyre damage can cause danger of death to vehicle occupants and also other road-users. ◀



Repairing tyre damage

For safety reasons, the manufacturer of your vehicle advises against having damaged run-flat tyres repaired; have them replaced instead. Otherwise subsequent damage cannot be excluded. ◀

Age of tyres

Recommendation

Irrespective of wear, change tyres after six years at the latest.

Date of manufacture

On the tyre side wall:

DOT ... 3611: the tyre was made in the 36th week of 2011.

Replacement of wheels and tyres

Fitting



Information on tyre mounting

Only have tyres fitted, including balancing, by your Service Centre or by a specialist tyre dealer.

If such work is performed inexpertly, it could result in consequential damage and thus constitute a safety risk. ◀

Wheel and tyre combination

Your Service centre can provide details of the right wheel/tyre combination and rim designs for your car.

Incorrect wheel and tyre combinations will interfere with the proper functioning of various systems, such as ABS and DSC.

To maintain good vehicle handling, always fit tyres of the same make and tread pattern to all wheels.

After a tyre has been damaged, fit the original wheel and tyre combination again.



Approved wheels and tyres

The manufacturer of your vehicle recommends using only wheels and tyres that have been approved for a specific vehicle type.

Even if nominally the same dimension, tyres could make contact with the body, for example due to manufacturing tolerances and result in serious accidents.

The manufacturer of your vehicle is unable to assess the suitability of tyres and wheels it has not approved, and therefore cannot guarantee their safety. ◀

Recommended makes of tyre



Certain makes of tyre are recommended by the manufacturer of your vehicle depending on tyre size. These can be seen by the asterisk on the side wall of the tyre.

When properly used, these tyres meet the highest standards in terms of safety and handling characteristics.

New tyres

New tyres do not achieve their full road grip immediately, for production reasons.

During the first 300 km, 200 miles, drive moderately.

Retreaded tyres

The manufacturer of your vehicle advises against the use of retreaded tyres.



Retreaded tyres

Due to their potentially different internal construction and advanced age, their durability may be limited and their road safety therefore questionable. ◀

Winter tyres

Winter tyres are recommended for operation on winter roads or at temperatures below +7 °C/+45 °F.

Although so-called all-season tyres with an M+S marking have better winter characteristics than summer tyres, they do not normally match the performance of winter tyres.

Top speed of winter tyres

If the car is capable of speeds higher than the speed permitted for the winter tyres, a sticker stating the maximum permitted speed for the tyres fitted must be displayed in the driver's field of view. Specialist tyre dealers and your Service centre can supply the sticker.



Top speed for winter tyres

Do not exceed the top speed for the winter tyres in use, otherwise tyre damage potentially leading to an accident could occur. ◀

Run-flat tyres

For your own safety, when using run-flat tyres, do not mix with other types of tyre. There is no spare wheel available in the event of a puncture. Your Service centre will be pleased to advise.

Interchanging front and rear wheels

The manufacturer of your vehicle advises against interchanging the front and rear wheels. This could impair vehicle handling.

Tyre storage

Store wheels and tyres in a cool, dry and preferably dark place when not in use.

Protect tyres against contamination from oil, grease and fuel.

Do not exceed the maximum tyre pressure indicated on the tyre's side wall.

Run-flat tyres

Label



RSC marking on the tyre side wall.

These wheels consist of tyres that are self-supporting within certain limitations, and special rims.

The reinforced side wall means that the tyre keeps the vehicle mobile to a degree even if pressure has been lost.

Continue driving with the damaged tyre, see page 96.

Changing run-flat tyres

For your own safety, use only run-flat tyres.

There is no spare wheel available in the event of a puncture. Your Service centre will be pleased to advise.

Remedying punctures



Safety precautions in the event of a puncture

Park the vehicle on a solid surface and as far away from moving traffic as possible.

Switch on hazard warning lights.

Engage the steering wheel lock in the straight ahead position of the wheels.

Secure the vehicle against rolling away, also apply the parking brake and with automatic gearbox engage the P position.

Allow all occupants get out of the vehicle and guide them out of the danger area, for example behind the crash barrier.

Set up warning triangle an appropriate distance away.

Comply with relevant local laws. ◀

Mobility system

Notes

- ▷ Please observe the instructions on the application of the Mobility system which are on the compressor and the sealant cylinder.
- ▷ Applying the Mobility system can be ineffective for tyre damage as from a size of approximately 4 mm.
- ▷ Contact a Service centre if you are unable to put the tyre back in operation.
- ▷ If possible, foreign matter that has penetrated the tyre should remain inside the tyre.
- ▷ Remove the speed limit sticker from the sealant cylinder and attach to the steering wheel.

Storage

The Mobility system is located in the boot beneath the floor panel.

Sealant cylinder



- ▷ Sealant cylinder, arrow 1.
- ▷ Filler hose, arrow 2.

Check the expiry date on the sealant cylinder.

Compressor

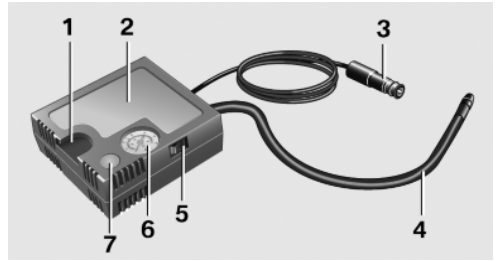

- 1 Mounting for cylinder
- 2 Compressor
- 3 Plug/cable for socket
- 4 Connecting hose
- 5 On/Off button
- 6 Tyre inflation pressure display
- 7 Reduce tyre inflation pressure

Fill with sealing compound

1. Shake sealant cylinder.



2. Remove the connecting hose entirely from the compressor housing. Do not kink the hose.

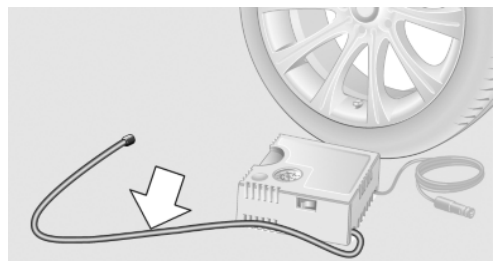

3. Bolt the connecting hose onto the connector of the sealant cylinder.

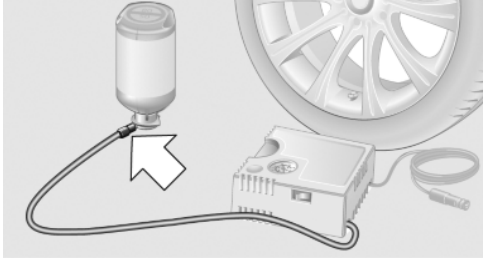

4. Insert the upright sealant cylinder into the compressor housing.

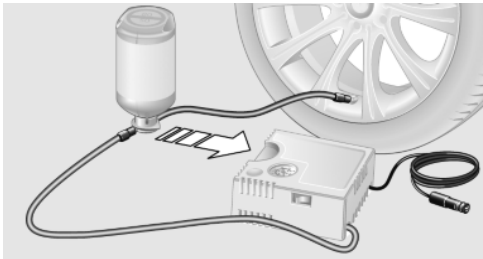

5. Bolt the filler hose of the sealant cylinder onto the valve of the punctured wheel.

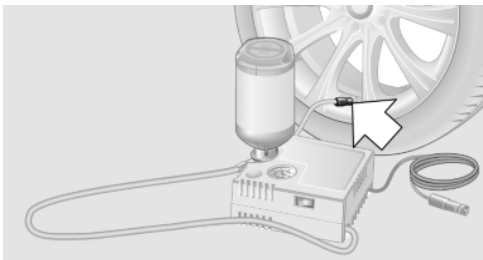

6. Insert the plug into the socket on the inside of the vehicle while the compressor is switched off.

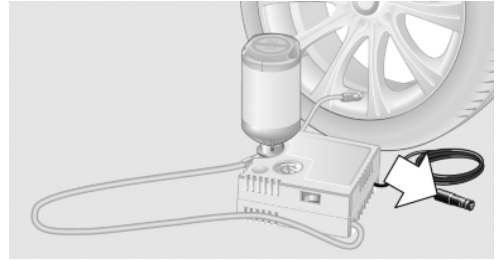

7. Switch on the compressor with the ignition switched on or the engine running.

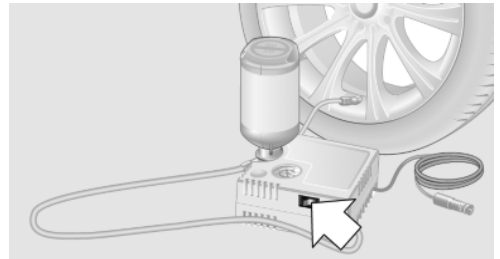

Let the compressor run for approximately three to 8 minutes to fill the sealing compound and achieve a tyre inflation pressure of approximately 2.5 bar.

The inflation pressure may rise to approximately five bar during the filling process of the sealing compound. Do not switch off the compressor during this step.

Enclosed spaces

Never run the engine in enclosed spaces, as inhaling the exhaust gas can lead to loss of consciousness with fatal consequences. The exhaust gas contains carbon monoxide, which is colourless and odourless, but highly toxic. ◀

Switch off compressor after ten minutes

Do not operate the compressor for more than ten minutes, otherwise the device will over-heat and this could result in damage. ◀

If it does not reach a pressure of 2 bar:

1. Switch off compressor.
2. Remove the filler hose from the wheel.
3. 10 m/400 inches to distribute the sealing compound in the tyre.
4. Re-inflate the tyre with the compressor.
Contact a Service centre if the device does not reach a tyre inflation pressure of 2 bar.

Store Mobility system

1. Remove the filler hose of the sealant cylinder from the wheel.
2. Unscrew the connecting hose of the compressor from the sealant cylinder.
3. Connect the filling hose of the sealant cylinder that was previously connected with the valve with the free connection on the sealant cylinder.
This can prevent sealant residues from escaping from the cylinder.
4. Pack empty sealant cylinder to avoid soiling in the boot.
5. Store Mobility system in the car again.

Spread sealant compound

Immediately drive for approx. 10 km/5 miles to evenly distribute the sealing compound in the tyre.

Do not exceed a speed of 80 km/h, 50 mph.

If possible, not do drive slower than 20 km/h, 12 mph.

Correcting the tyre inflation pressure

1. Stop in a suitable area.
2. Bolt the connecting hose of the compressor directly onto the tyre valve.
3. Insert the plug into the socket on the inside of the vehicle.
4. Correct tyre inflation pressure to 2.5 bar.

- ▷ Increase pressure: switch on the compressor with the engine running or the ignition switched on.
- ▷ Reduce pressure: press the button on the compressor.

Continue with journey

Do not exceed maximum permitted speed of 80 km/h, approx. 50 mph.

Reinitialise runflat indicator, see page 95.

Have the punctured tyre and the sealant cylinder of the Mobility system replaced as soon as possible.

Snow chains

Fine-link snow chains

Only certain fine-link snow chains have been tested, found safe for use in traffic, and recommended by the manufacturer of your vehicle.

The Service centre is able to provide the details of these makes.

Use

Snow chains may only be used in pairs on the rear wheels with tyres of the following sizes:

- ▷ 205/65 R 17.
- ▷ 225/60 R 17.
- ▷ 245/50 R 18.
- ▷ 245/45 R 19.



Do not use snow chains on tyres of size 245/55 R 17

Do not fit tyres of size 245/55 R 17 with snow chains as otherwise the vehicle could be damaged. ◀

Observe the chain manufacturer's instructions. Ensure that the snow chains are always adequately taut. Re-tighten them if necessary in accordance with the chain manufacturer's instructions.

Do not initialise the runflat indicator with snow chains fitted, as the instrument might otherwise issue an incorrect reading.

When driving with snow chains, activate Dynamic Traction Control briefly if necessary.

Maximum speed with snow chains

When snow chains are fitted, do not exceed 50 km/h, 30 mph.

Engine compartment

Vehicle Equipment

This chapter describes all standard, national and special equipment provided in the model series.

Therefore equipment not available in a vehicle is also described, for example the selected special equipment or national version. That also applies to safety-relevant functions and systems.

Important accessories in the engine compartment

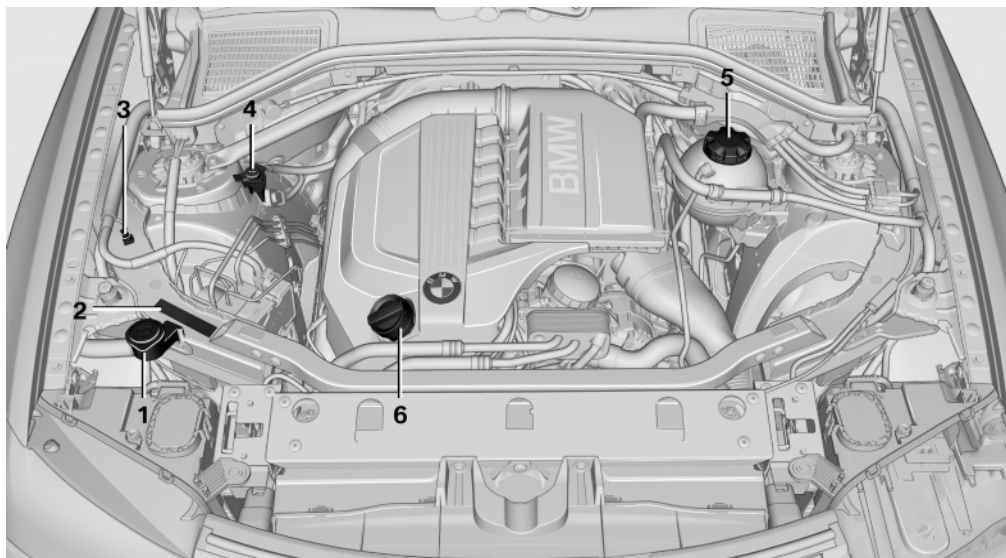

- | | |
|--|--|
| 1 Reservoir for washer fluid | 4 Starting assistance, positive terminal |
| 2 Identification number | 5 Coolant tank |
| 3 Starting assistance, negative terminal | 6 Oil filler neck |

Bonnet

Open bonnet

 Working in the engine compartment
Do not work on the car unless you possess the necessary technical knowledge.

If you are not aware of the regulations to follow, work on the vehicle should only be carried out by Service.

If such work is performed inexpertly, it could result in consequential damage and thus constitute a safety risk. ◀

 Do not reach into the engine compartment
Do not reach into intermediate spaces or gaps in the engine compartment. Otherwise there is the risk of injury, for example, due to rotating or hot parts. ◀

1. Pull the lever.

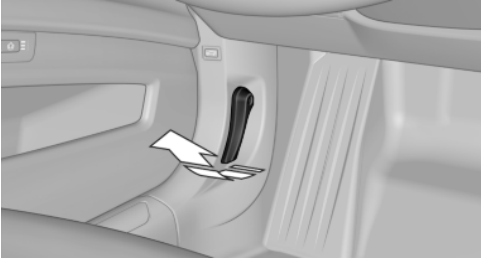

2. Press the release lever and open the bonnet.

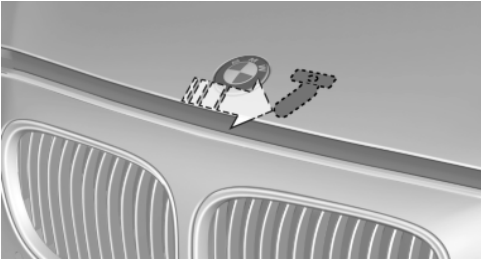

3. Watch out for any protruding parts of the bonnet.

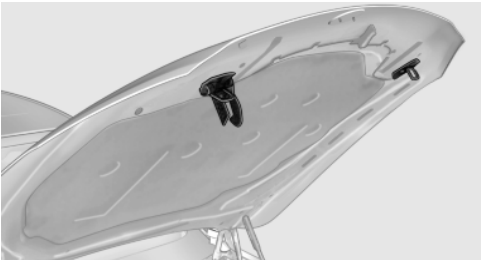

- !** Risk of injury with the bonnet open
With the bonnet open, protruding parts represent a risk of injury. ◀

Closing bonnet



Let the bonnet fall from approximately 40 cm, 16 in and then push down to fully lock the bonnet.

The bonnet must be heard to engage.

- !** Bonnet open while the vehicle is in motion
Should it appear while the vehicle is in motion that the bonnet has not been properly locked, stop immediately and close properly. ◀

- !** Risk of trapping
To avoid injuries, ensure that the closing area of the bonnet is unobstructed during closing. ◀

Engine oil

Vehicle Equipment

This chapter describes all standard, national and special equipment provided in the model series. Therefore equipment not available in a vehicle is also described, for example the selected special equipment or national version. That also applies to safety-relevant functions and systems.

General

The engine oil consumption depends on the driving style and operating conditions.

Therefore check the engine oil level regularly after each time you fill up.

For X3 xDrive20i and X3 xDrive28i: Oil level check

Principle

The oil level is electronically monitored when travelling and shown on the control display.

If the oil level reaches the minimum, a check control message is shown.

Displaying oil level

1. "Vehicle information"
2. "Vehicle status"
3.  "Engine oil level"

Possible messages

- ▷ "Engine oil level OK"
- ▷ "Engine oil at minimum. Add 1 litre of engine oil!"
Top up within the next 200 km, 120 miles top up 1 litre, 2 pints of oil.
- ▷ "Engine oil level below minimum. Add one litre!"

Immediately top up 1 litre, approximately 2 pints oil.

Detailed measurement

Prerequisites:

- ▷ Vehicle is on a level street and with the engine at operating temperature.
- ▷ Gearbox: gear lever in idling position, clutch and gas pedal not applied.
- ▷ Automatic gearbox: gear lever in gearbox position N or P and gas pedal not applied.

Carry out a detailed measurement of the engine oil level:

1. "Vehicle information"
2. "Vehicle status"
3.  "Measure engine oil level"
4. "Start measurement"

The oil level is checked and shown on a scale.

During the detailed measurement, the idling speed is slightly raised.

Duration: approximately 1 minute.

All other models: Oil level check

Principle

The oil level is electronically monitored when travelling and shown on the control display.

If the oil level reaches the minimum, a check control message is shown.

Requirements

- ▷ Engine running and at operating temperature after driving at least 10 km, 6 miles.
- ▷ Vehicle stationary and on level surface.

Displaying oil level

1. "Vehicle information"
2. "Vehicle status"
3.  "Engine oil level"

Possible messages

- ▷ "Engine oil level OK"
- ▷ "Measurement not possible at this time."
- ▷ "Measuring engine oil level..."

Duration with engine running: approximately three minutes.

Duration while the vehicle is in motion: approximately five minutes.
- ▷ "Engine oil level below minimum. Add one litre!"

Top up oil within the next 200 km, 120 miles.
- ▷ "Engine oil level too high! Have this checked."

Have the car checked as soon as possible.



Too much engine oil

Have the car examined immediately, otherwise too much oil could result in engine damage. ◀

- ▷ "Measurement inactive. Have this checked."

Note the recalculated distance remaining until the next Oil Service. Have the system checked as soon as possible.

Adding engine oil

Filler neck



If indicated in the instrument cluster, top up within the next 200 km, 120 miles top up 1 litre, 2 pints of oil.



Protecting children

Keep all oils, greases etc. out of the reach of children, and read and comply with any warning instructions on the containers, to avoid any health risks. ◀

Oil types for filling up

Notes



No oil additives

Oil additives could lead to engine damage. ◀



Viscosity classes with engine oils

When selecting an engine oil, ensure that the motor oil has one of the viscosity classes SAE 0W-40, SAE 0W-30, SAE 5W-40 oder SAE 5W-30 otherwise functional disruptions or engine damage may occur. ◀

The engine oil quality is decisive for the life or the engine.

Several oil types are not available in all countries.

Approved oil grades

Petrol engine

BMW Longlife-01

BMW Longlife-01 FE

BMW Longlife-04

Diesel engine

BMW Longlife-04

Further information on approved types of oil can be asked for at the Service centre.

Alternative oil grades

If approved oils are not available 1 litre, approximately 2 pints of an oil with the following specification can be topped up:

Petrol engine

BMW Longlife-98

ACEA A3/B4

Diesel engine

ACEA C3

Oil change

Only have the oil change carried out by a Service centre.

BMW recommends 

Coolant

Vehicle Equipment

This chapter describes all standard, national and special equipment provided in the model series. Therefore equipment not available in a vehicle is also described, for example the selected special equipment or national version. That also applies to safety-relevant functions and systems.

General

 **Danger of scalding while the engine is hot**
Do not open up the cooling system while the engine is hot, otherwise you may scald yourself on the escaping coolant steam. ◀

 **Suitable additives**
Use only suitable additives, otherwise the engine could incur damage. The additives are injurious to health. ◀

Coolant is a mixture of water and an additive. Not all commercially available additives are suitable for your vehicle. Your Service centre can provide details of which additives are suitable.

Coolant level

Check

1. Allow the engine to cool down.
2. Turn the cap on the expansion tank slightly anti-clockwise until it starts to open, then al-

low the pressure to escape before opening it fully.

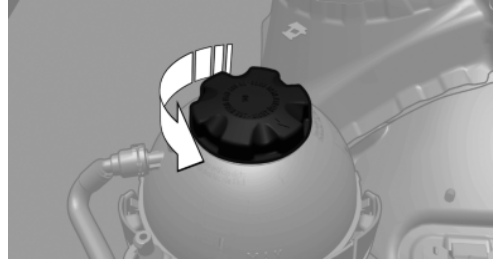

3. The coolant level is correct if it is between the Min. and Max. marks in the filler neck.



4. If necessary, slowly top up to the correct level; do not overfill.
5. Fit the cap and turn until it is clearly heard to click into place.
6. Have the cause of coolant loss rectified as soon as possible.

Disposal



When disposing of coolant and coolant additives, comply with the relevant environmental protection regulations.

Maintenance

Vehicle Equipment

This chapter describes all standard, national and special equipment provided in the model series. Therefore equipment not available in a vehicle is also described, for example the selected special equipment or national version. That also applies to safety-relevant functions and systems.

BMW Maintenance System

The maintenance system points out the necessary maintenance measures and so supports you in maintaining the road and operational safety of the vehicle.

Condition Based Service, CBS

Sensors and advanced algorithms monitor the conditions in which your vehicle is used. Condition Based Service uses this information to calculate the maintenance requirements.

The system thus enables adaptation of the scope of maintenance to the individual usage profile.

Detailed information on service requirements, see page 77, can be displayed at the control display.

Service data in the remote control

Information on maintenance requirements is continually saved in the remote control. The Service centre reads out this data and then suggests a set of maintenance routines optimised on this basis.

This is why you should hand over the remote control that was last used for driving to your service advisor.

Periods out of use

Immobilisation periods with the battery disconnected are not taken into account.

Updating the time-dependent maintenance scope such a brake fluid and any engine oil and microfilter or activated carbon filter can be done by a Service centre.

Service Booklet

Have maintenance work carried out by the Service centre confirmed in the service booklet. The entries in it serve as proof of regular maintenance.

For Australia/New Zealand: Maintenance

No maintenance work other than normal maintenance is required to keep the emission levels of your vehicle within the design limits.

Overview: maintenance schedule

Standard schedule

Maintenance work

Examine Check Control messages.

Examine indicator and warning messages.

Engine oil

Maintenance work

Replace engine oil and oil filter.

Automatic air conditioning: replace the micro-filter.

With a petrol engine:

With every second engine oil change.

Replace spark plugs

With diesel engine:

With every second engine oil change.

Replace the fuel filter, with lower fuel grades, shorten the replacement interval.

With every second engine oil change.

Intake noise damper: replace air-filter element; with heavier dust deposit, reduce change interval.

Reset service display in line with workshop guidelines.

Front brake

Maintenance work

Replace brake pads, clean brake shafts.

Brake discs: check surface and thickness.

Reset service display in line with workshop guidelines.

Rear brakes

Maintenance work

Replace brake pads, clean brake shafts.

Brake discs: check surface and thickness.

Parking brake: check functionality.

Reset service display in line with workshop guidelines.

Brake fluid

Maintenance work

Replace brake fluid.

Reset service display in line with workshop guidelines.

Vehicle check

Maintenance work

Check horn, headlight flasher and hazard warning system.

Check instrument lighting and dial lighting and heating fan.

Check lighting system.

Seat belt: check condition of the seat belt strap, function of roller mechanism, belt interlock and belt buckle.

Check windscreen wiper and washer system.

Mobility system: check expiry date on the sealant bottle.

Tyres: tread depth, running surface, check outer condition and filling pressure.

Initialise runflat indicator RPA.

Check the coolant level and concentration.

Windscreen washer: check fluid level.

Brake hoses and connectors: check for leaks, damage and correct position.

Underbody, including all visible parts: check for damage, corrosion, sealing including seal of shock absorbers and check the fitting of springs.

Steering components: check clearance, leaking, damage and wear.

Maintenance work

Check for road safety, test drive: braking, steering, shock absorbers, gears.

Reset service display in line with workshop guidelines.

Separate calculation

Replacement work, spare parts, operating materials and wear material are calculated separately. You can get further information from the Service centre.

Socket for on-board diagnosis, OBD

Position

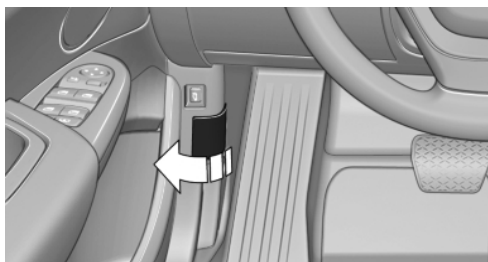

The OBD socket for checking components definitive in terms of the composition of the exhaust emissions is on the driver's side.

Emissions



- ▷ The warning light flashes:
Engine malfunction that could damage the catalytic converter. Have the car checked as soon as possible.
- ▷ The warning light is illuminated:
Deterioration of exhaust emissions. Have the car checked as soon as possible.

Data memory

Your vehicle saves data about operation, faults and user settings. This data is saved in the vehicle and partly also in the remote control. The information can be read out with suitable devices, especially at the Service centre. The data read-out is used to support service processes and repair or for optimising and developing vehicle functions.

If there is also a BMW Assist contract, certain vehicle data can also be send directly from the vehicle to allow the desired services.

Recycling

The manufacturer of your vehicle recommends handing the vehicle in at a take-back point nominated by the BMW Group. The regulations concerning the returning of end-of-life vehicles may vary from country to country. Your Service centre will be glad to provide information.

Replacing parts

Vehicle Equipment

This chapter describes all standard, national and special equipment provided in the model series. Therefore equipment not available in a vehicle is also described, for example the selected special equipment or national version. That also applies to safety-relevant functions and systems.

On-board tool kit

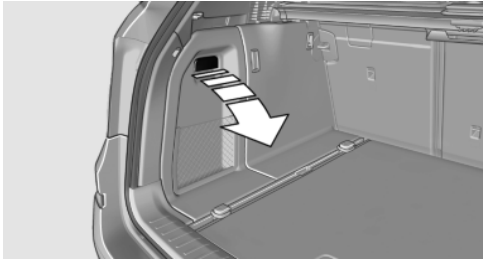

The tool kit is located behind the left flap in the boot under the first aid kit.

Replacing the wiper blades

General

 Do not fold the wipers onto the wind-screen without wiper blades

Do not fold in wiper if no wiper blades are fitted, otherwise damage may occur to the window glass. ◀

Replacing front wiper blades

1. To replace the wiper blades, place the wipers in the fold-out position, see page 67.
2. Fold out the wipers.

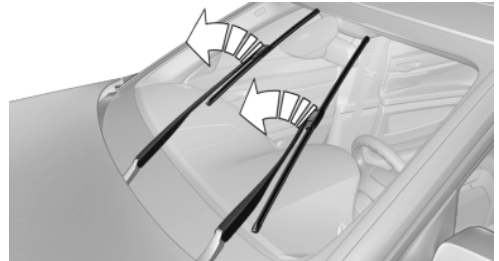

3. Swing the wiper blade into a horizontal position.
4. Remove the wiper blade towards the side.



Change rear wiper blade

1. Pull wiper arm up fully and pull off wiper blade, see arrow.



2. Insert new wiper blade. It must be heard to engage.

Replacing bulbs

General

Lights and bulbs are an important aspect of driving safety.

The manufacturer of the vehicle recommends that you have the corresponding work carried out by the Service Centre, if you are not familiar with them or they are not described here.

A replacement bulb box can be obtained from the Service centre.

! Risk of sustaining burns
Only change bulbs while they are cool to the touch. Otherwise, burns could result. ◀

! Working on the lighting system
Before performing any work on the lighting system, switch off the lights in question, otherwise there is a risk of short-circuits.

Observe any instructions supplied by the bulb manufacturer to avoid the risk of injury or damage when changing bulbs. ◀

! Do not perform any work on or replace bulbs on the xenon lights

Work on the xenon light system, including changing the bulb, must always be performed by a Service centre. Otherwise there is a risk of potentially fatal accidents if work is performed inexpertly, because of the high electrical voltages present. ◀

! Do not touch the bulbs
Do not touch the glass of a new bulb with your fingers, because even slight amounts of dirt or grease will then be burned into the bulb and reduce its working life.

Use a clean tissue, cloth or similar, or hold the bulb by its base. ◀

Light-emitting diodes, LEDs

Controls, displays and other equipment items inside your car have light-emitting diodes behind a cover as their light source.

These resemble conventional lasers and are classified by legislation as Class 1 light-emitting diodes.

! Do not remove the covers
Do not remove the covers or expose the eyes directly to the unfiltered light source for several hours at a time, as this could cause irritation to the retina. ◀

Headlight glass

During cool or humid weather, the exterior lights can mist over. When driving with the light switched on, the condensation disappears after a short time. There is no need to replace the headlight glass.

If the headlights do not defrost, even when driving with the lights switched on and increasing moisture builds up, for example water droplets in the lights, have these checked by the service centre.

Front lights, replacing the bulbs

Overview

Halogen headlights

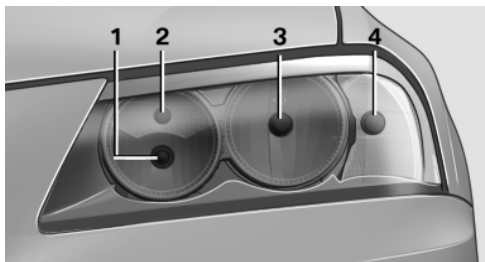

- 1 High-beam headlights/headlight flasher
- 2 Side lights
- 3 Low-beam headlights
- 4 Turn indicator

Xenon headlight

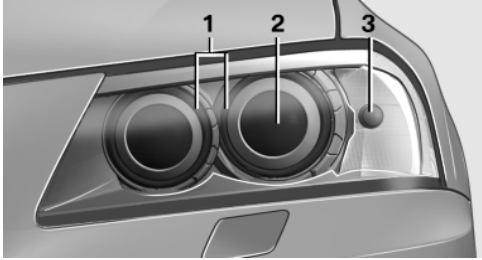

- 1 Side lights/daytime driving lights
- 2 Low-beam headlights/high-beam headlights/headlight flasher
- 3 Turn indicator

Halogen headlights

Low-beam headlights

Follow the instructions regarding bulbs and lights, see page 264.

H7 bulb, 55 watts

1. Open bonnet, see page 254.
2. Turn cover anti-clockwise and remove.

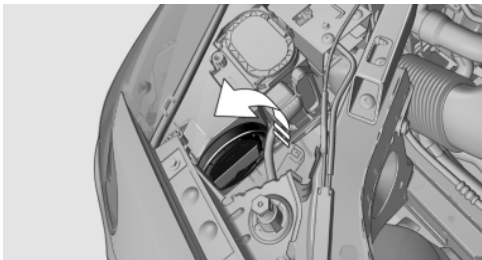

3. Carefully pull out connector.
4. Pull off bulb from connector and connect new bulb.
5. To install the new bulb and reattach the cover, carry out the above steps in reverse order.

High-beam headlights/headlight flasher and side lights

Follow the instructions regarding bulbs and lights, see page 264.

High-beam headlights/headlight flasher:
55 watt bulb, H7

Side lights: 5 watt bulb, W5W

1. Open bonnet, see page 254.
2. Press, see arrow 1, and fold out cover, see arrow 2.

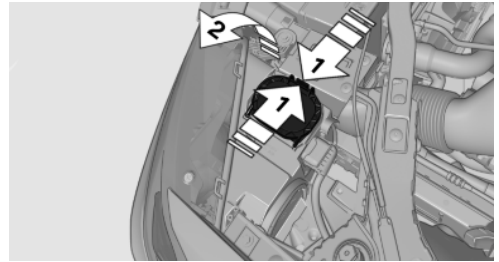

3. Remove bulb holder.
The bottom bulb is the high-beam headlights and the headlight flasher, the top bulb is the side lights.
4. Pull off the bulb.
5. To install the new bulb and reattach the cover, carry out the above steps in reverse order.

Xenon light

These bulbs have a very long service life and are highly unlikely to fail. Frequent switching on and off shortens the service life.

If a bulb fails, you can continue driving moderately with fog lights. Observe any applicable country-specific laws.

 Do not perform any work on or replace bulbs on the xenon lights

Work on the xenon light system, including changing the bulb, must always be performed by a Service centre. Otherwise there is a risk of potentially fatal accidents if work is performed

inexpertly, because of the high electrical voltages present. ◀

Xenon headlight

The low-beam headlights and high-beam headlights use xenon technology.

The side lights and daytime driving lights use LED technology.

In the event of a defect, contact your Service centre.

Front fog lights

Follow the instructions regarding bulbs and lights, see page 264.

Fog lights when equipped with Adaptive Headlights: 55 watt bulb, H11

Fog lights without Adaptive Headlights: 35 watt bulb, H8

1. Insert the screwdriver from the tool kit into the clamp on the removal hook with the flat side facing out, see arrow 1.

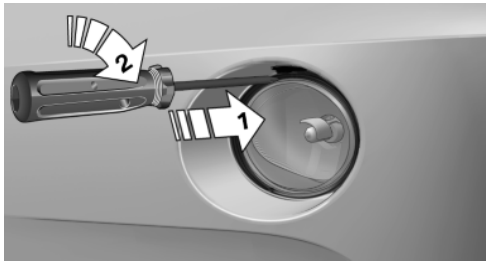

2. Turn screwdriver 90°, see arrow 2.

3. Press removal hook up, see arrow, and move fog lights forwards on the hook to remove them.

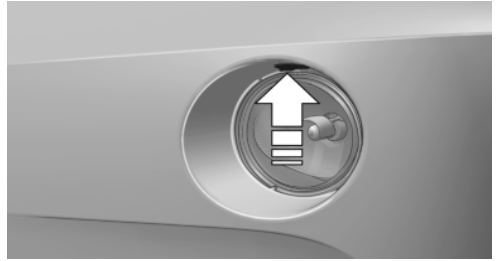

4. Loosen connector.

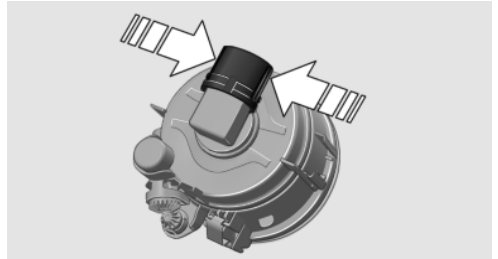

5. Turn lamp holder and remove.

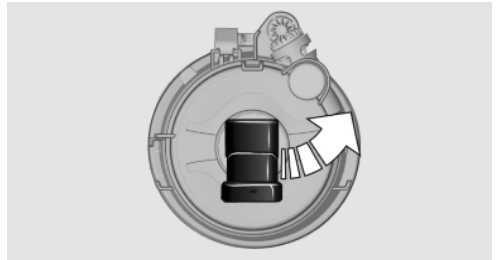

6. Take out the bulb and change it.
7. To insert the fog lamp, carry out the same procedure in reverse order. Observe the guide rails when doing this.

Turn indicator

Follow the instructions regarding bulbs and lights, see page 264.

The turn indicator is located in the engine compartment beside the low-beam headlights each time.

21 watt bulb, PY 21W

1. Open bonnet, see page 254.
2. Turn cover anti-clockwise and carefully remove.

The bulb is attached to the cover.

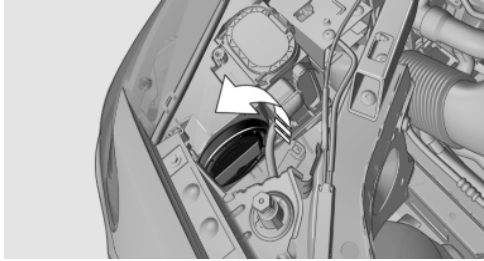

3. Turn the bulb clockwise to remove it.
4. To install the new bulb and reattach the cover, carry out the above steps in reverse order.

Side turn indicators

Follow the instructions regarding bulbs and lights, see page 264.

These lights use LED technology.

In the event of a defect, contact your Service centre.

Rear lights, replacing the bulbs

Overview

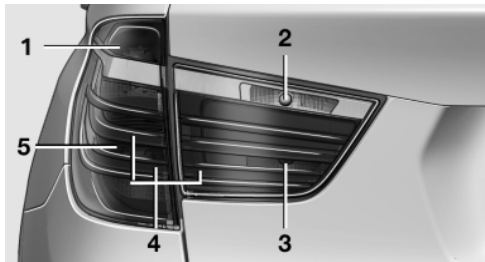

- 1 Turn indicator
- 2 Reversing lights
- 3 Rear fog light

- 4 Rear light
- 5 Rear light/brake light

Turn indicator, rear light and brake light

Follow the instructions regarding bulbs and lights, see page 264.

21 watt bulb, P21W

With adaptive headlights or xenon headlights: rear lights are designed with LED technology. In the event of a defect, contact your Service centre.

1. Opening the tailgate.
2. Insert screwdriver from the tool kit between the cover and body, push up, see arrow, and remove cover.

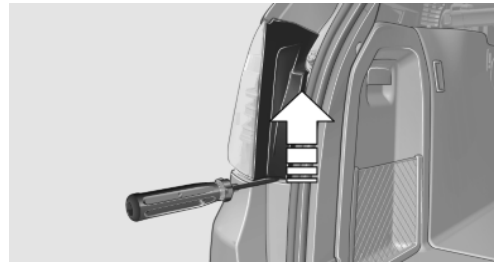

3. Remove nuts.

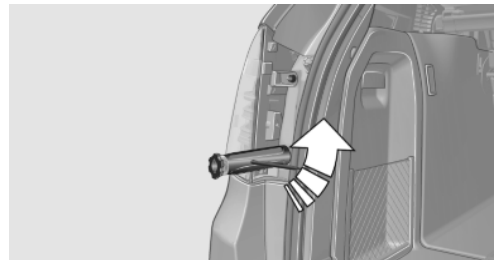

4. Remove rear lights from body and remove connector.

- Undo three fastenings on the bulb holder and remove bulb holder from the rear light.

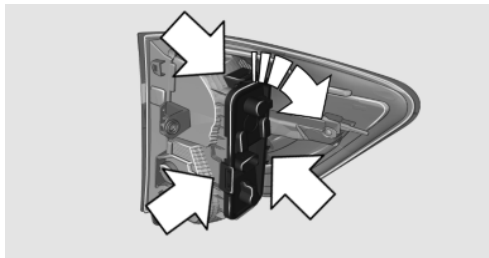

- Turn bulb and remove. The turn indicator is the top bulb, the rear light/brake light is the bottom bulb on the bulb holder.
- To install the new bulb and reattach the bulb holder, carry out the above steps in reverse order. Ensure that the bulb holder is engaged in all fastenings.
- Connect up rear lights and fit.
- Put the cover with the three brackets in the rear light. By pressing on the upper and lower bracket, push the cover downwards until it engages.

Reversing light and fog light

Follow the instructions regarding bulbs and lights, see page 264.

Reversing light: 16 watt bulb, W16W

Rear fog light: 21 watt bulb, H21W

- Opening the tailgate.
- Pull out cover on handle recess, see arrow.



- Loosen connector.
- Remove bulb holder from rear light.

Reversing light is the upper light, the fog light is the lower light on the bulb holder.

- To change the reversing light, carefully pull out the bulb.

To change the rear fog light, push the bulb downwards and turn it towards the left.

- To install the new bulb and reattach the bulb holder, carry out the above steps in reverse order.

Ensure that the bulb holder is correctly inserted.

Changing a wheel

Notes

Due to the vehicle equipment, no spare wheel is available.

For tyres with emergency running properties or when using tyre sealants, immediate wheel change for tyre pressure loss in case of breakdown is not required.

The tools for changing wheels are available as optional accessories from your Service centre.

Jack mounting points

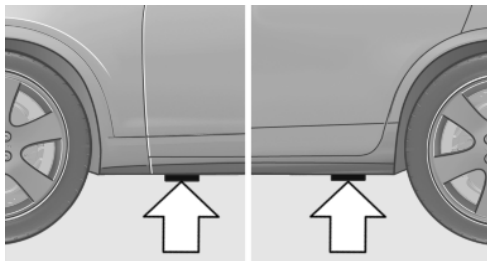

The jacking points are at the positions marked.

Thiefproof wheel studs

The thiefproof wheel studs can be found in the tool kit or in an oddments tray in the tool kit, see page 263.

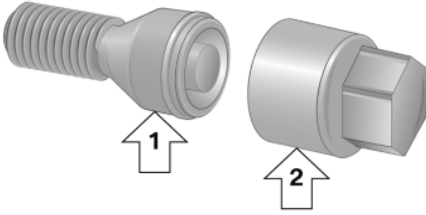

- ▷ Wheel stud, arrow 1.
- ▷ Adapter, arrow 2.

Removing

1. Place the adapter on the wheel stud.
2. Unscrew wheel stud.

After reattaching the wheel stud, remove the adapter again.

Car battery

Maintenance

The battery does not require routine maintenance, in other words the quantity of acid it contains is sufficient for the full operating life of the battery.

If you have any queries regarding the battery, your Service centre will be pleased to advise you.

Replacing the battery



Only use approved vehicle batteries.

Only use vehicle batteries that are approved by the manufacturer of your vehicle. Otherwise the vehicle may be damaged and availability of systems or functions may be limited. ◀

When the vehicle battery has been changed, have the battery registered on the vehicle by your Service centre to ensure that all comfort functions are fully available and any appropriate Check Control messages are no longer displayed.

Recharging the battery

Note



Do not connect charger to socket
Do not connect battery charger to the sockets installed in the vehicle in the factory, otherwise this could damage the vehicle. ◀

Jump-starting connections

Recharge the battery only with the engine stopped, via the jump-starting connections, see page 273, in the engine compartment.

Charger

The user of a charger makes sure the battery is sufficiently charged even when making frequent short trips. Chargers developed especially for the vehicle and attuned to the on-board network can be obtained from the Service centre.

Power failure

After a temporary power supply interruption, some items of equipment must be reinitialised.

Individual settings must be updated:

- ▷ Seat and mirror memory: re-save positions.
- ▷ Time: update.
- ▷ Date: update.
- ▷ Radio transmitter: re-save.
- ▷ Navigation system: wait until the navigation is functioning properly.

Disposing of the old battery



Dispose of old batteries only at an authorised collecting point or hand them in to your Service centre.

Batteries filled with acid should be transported and stored upright. Protect batteries against falling over when in transit.

Fuses

Notes



Replacing fuses

Do not repair blown fuses or replace them with fuses with different colours or ampere ratings, otherwise overloaded electrical wires could cause a fire in the vehicle. ◀

Plastic tweezers and details of the fuse assignment can be found with the fuses in the boot.

In the glove box

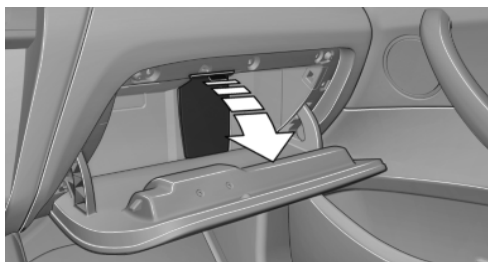

Pivot the flap down, see arrow.

Inside the boot

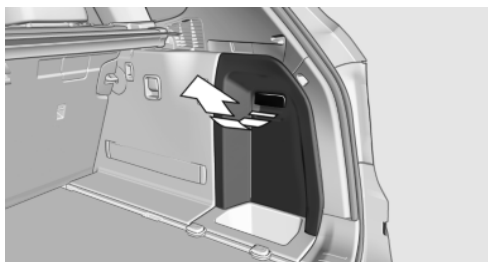

Open the cover on the right side trim panel and remove the sound insulation.

Details of the fuse assignment are on a separate leaflet.

Help in the event of a breakdown

Vehicle Equipment

This chapter describes all standard, national and special equipment provided in the model series. Therefore equipment not available in a vehicle is also described, for example the selected special equipment or national version. That also applies to safety-relevant functions and systems.

Hazard warning lights

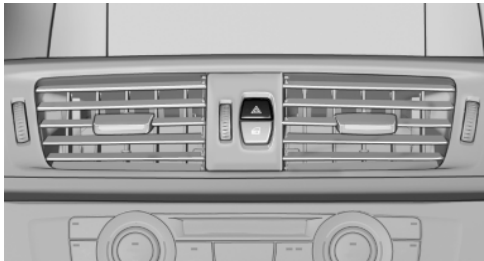

The button is located in the centre console.

Emergency call

Requirements

- ▶ Equipment with preparation for mobile phone.
- ▶ An emergency call is also possible when no mobile phone is connected to the vehicle.
- ▶ BMW Assist is activated.
- ▶ Radio ready state is switched on.
- ▶ BMW Assist system is connected to a mobile communications network supported by BMW Assist.
- ▶ Emergency call system functional.

Press the SOS button in an emergency only.

Even if no BMW Assist emergency call is possible, in some cases an emergency call may still be set up to a public emergency call number.

This depends on factors such as the specific mobile phone network and the national regulations.



Emergency call not ensured

For technical reasons, it might not be possible to make an emergency call in highly adverse conditions. ◀

Subscriber contract

- ▶ The Service centre can deactivate the BMW Assist system after expiration of the participation contract without you having to visit the workshop.
- ▶ After deactivation of the system, no BMW Assist emergency call is possible.
- ▶ It is possible that the system can be re-enabled by the Service centre after conclusion of a new contract.

Making an emergency call



1. Briefly press the cover flap to open it.
 2. Press the SOS button until the LED in the button is illuminated.
- ▶ LED illuminated: emergency call activated.
- If a cancellation request is displayed on the control display, the emergency call can be aborted.
- If the situation permits, wait in the car until voice contact has been established.

- ▶ LED flashes when the connection to the emergency number has been established. In the case of a BMW Assist emergency call, the data required to decide on the rescue measures to be taken is transferred to the emergency call centre, for example the current position of the vehicle if this can be determined. If questions posed by the emergency call centre remain unanswered, rescue measures are automatically initiated.
- ▶ If the LED is flashing but the emergency call centre cannot be heard over the hands-free system, it is possible that the hands-free system is malfunctioning. However, the emergency call centre may still be able to hear you speak.

Automatically activating emergency calls

In certain circumstances, an emergency call may be placed automatically immediately after a serious accident. An automatic emergency call is not influenced by pressing the SOS button.

Warning triangle

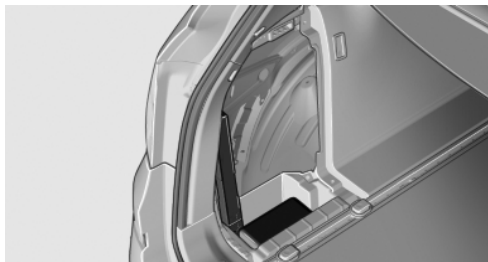

The warning triangle is located behind the left cover panel in the boot.

To remove, release the mounts.

First-aid kit

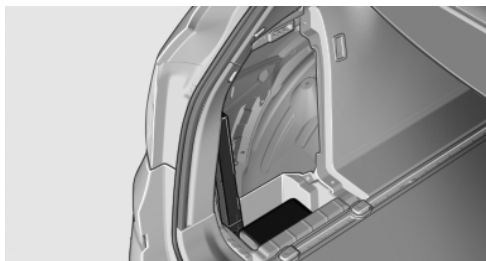

The first-aid kit is located behind the left cover panel in the boot.

The longevity of some articles is limited.

Check the use-by dates of the contents regularly and replace any items that have expired.

Mobile Service

Standby

In many countries, the Mobile Service is available by phone twenty-four hours a day, seven days a week. This service can render assistance in the event of a breakdown.

Breakdown assistance

If you need breakdown assistance, see page 231, use the iDrive to view the number or to establish a connection directly to the Mobile Service.

Starting assistance

Notes

If the vehicle battery is discharged, the engine can be started using two jump leads from another vehicle's battery. Use only jump leads with fully insulated terminal clamps.

Do not deviate from the procedure described below, as otherwise personal injury could result or both vehicles could be damaged.



Do not touch live parts

Do not touch any electrically live parts when the engine is running, or a fatal accident could occur. ◀

Preparations

1. Check whether the battery in the other vehicle shows 12 volts. Specifications are on the battery.
2. Switch off the engine of the donor vehicle.
3. Switch off any electrical systems in both vehicles.



Avoid contact between the vehicle bodies

The bodies of the two vehicles must not make contact, otherwise there is the risk of a short-circuit. ◀

Jump-starting connections



Order for connecting

Connect the jump leads in the correct order to avoid sparks that could cause injury. ◀

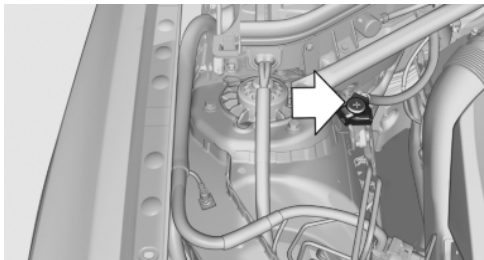

The jump-starting connection in the engine compartment serves as the positive battery terminal.

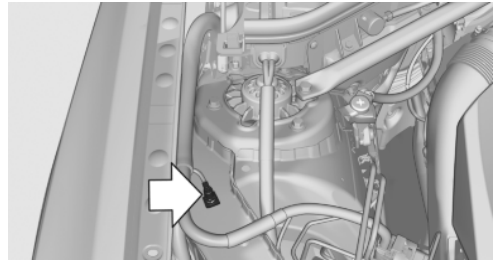

The negative terminal is the body earth or a special nut.

Connecting the cables

1. Pull up the cap of the BMW jump-starting connection to remove it.
2. Connect a terminal clamp on the positive/+ jump lead to the positive battery terminal or the corresponding jump-starting connection on the donor vehicle.
3. Connect the other terminal clamp to the battery's positive terminal or to the corresponding jump-starting connection on the vehicle to be started.
4. Connect a terminal clamp on the negative/- jump lead to the negative battery terminal or the corresponding engine or body earth connection on the donor vehicle.
5. Connect the second terminal clamp to the negative battery terminal or to a ground/earth connection on the corresponding engine or body of the vehicle to be started.

Starting the engine

Do not use the spray products sold as starting aids.

1. Start the engine of the donor vehicle and allow it to run for a few minutes at a slightly increased idle speed.
For diesel-engined vehicles to be started: allow the engine of the donor vehicle to run for approx. 10 minutes.
2. Start the engine of the vehicle to be started as normal.

If an initial attempt to start the engine fails, wait several minutes until the flat battery has been recharged to a slightly greater degree.

3. Allow both engines to run for a few minutes.
4. Disconnect the jump leads in the opposite order from that in which they were originally attached.

Check the battery if necessary and have it recharged.

Tow-starting and towing

Automatic transmission: transporting your vehicle

Note

Do not attempt to have your vehicle towed. Consequently, contact your Service centre in the event of a breakdown.

-  Do not tow the vehicle
Have your the vehicle transported on a load platform, otherwise damage might result. ◀

Towing truck

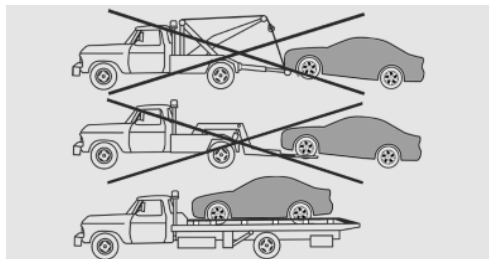

-  Do not raise the vehicle
Do not raise the car at the towing eye or by body or suspension components, otherwise it could be damaged. ◀

Use the towing eye screwed into the socket at the front of the car for manoeuvring only.

Manual gearbox

Before towing your vehicle

-  Parking brake blocked
It is not possible to manually disengage the parking brake.

With locked parking brake do not tow with raised front axle, otherwise the vehicle could be damaged.

Contact service. ◀

Gearshift lever in idle position.

Being towed

-  Comply with the instructions for towing/being towed

Comply with all instructions on towing/being towed; failure to do so could result in damage to the vehicle or an accident. ◀

- ▷ Make sure that the ignition is switched on, as otherwise low-beam headlights, rear lights, turn indicators and windscreen wipers would not be available.
- ▷ Do not tow the vehicle with the rear axle raised, as otherwise the steering can turn.
- ▷ When the engine is not running, there is no power assistance and the brake servo is out of action. The steering and brakes will require extra effort to operate.
- ▷ Greater steering wheel movements are necessary.
- ▷ The towing vehicle must not be lighter than the towed vehicle, otherwise it may be unable to keep the towed vehicle reliably under control.

Towing truck

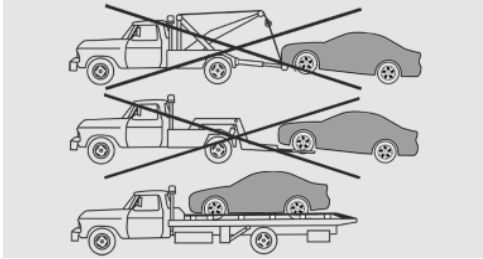

The BMW should only be transported on a loading platform.

! Do not tow the vehicle using individually raised front or rear axles

Do not tow the BMW using individually raised front or rear axles, as otherwise the wheels could jam and the transfer gearbox can be damaged. ◀

! Do not raise the vehicle
Do not raise the car at the towing eye or by body or suspension components, otherwise it could be damaged. ◀

Towing other vehicles

General

! Light towing vehicle
The towing vehicle must not be lighter than the towed vehicle, otherwise it may be unable to keep the towed vehicle reliably under control. ◀

! Attaching the tow bar/towing rope
Only attach the tow bar or towing rope to the towing eye. Attaching the towing rope to other parts of the car can result in damage. ◀

- ▶ Switch on the hazard warning flashers, depending on local regulations.
- ▶ If the car's electrical system has failed, the car being towed must be made identifiable to following vehicles, for instance by placing a notice or the warning triangle in the rear window.

Tow bar

The towing eyes of both vehicles should be on the same side.

If it is impossible to avoid attaching the tow bar at an angle, note the following:

- ▶ Tow bar clearance may be restricted when cornering.
- ▶ The tow bar will generate lateral forces if it is attached offset.

Towing rope

Ensure that the Towing rope is taut when the towing vehicle moves off.

For towing, use nylon ropes or straps, as these will help to avoid sudden tensile loads.

! Attaching the towing rope correctly
Only attach the towing rope to the towing eye. Attaching the towing rope to other parts of the car can result in damage. ◀

Towing eye

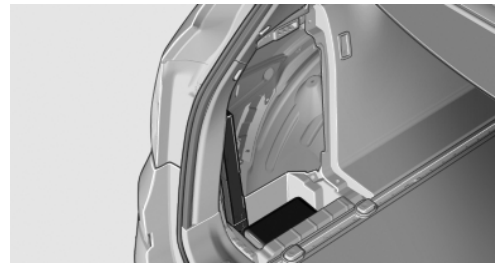

Always have the screw-on tow fitting on board the vehicle. It can be screwed into the front or rear end of the BMW. It is located in the tool kit behind the left flap in the boot.

- !** Towing eye, information on use
- ▶ Use only the towing eye supplied with the car, and make sure that it is screwed in fully and is tight.
 - ▶ Only use the towing eye for towing on normal roads (i.e. not off-road).

- ▶ Avoid lateral loads on the towing eye, for example do not raise the car at the towing eye.

Otherwise the towing eye and the car could be damaged. ◀

Screw thread

Press the upper edge of the cover to press it out.

Front



Rear



Tow-starting

Automatic transmission

Do not attempt to tow-start or push-start the vehicle.

Due to the automatic transmission, it is not possible to start the engine by towing.

Have the cause of the starting difficulties rectified.

Manual gearbox

If possible, do not tow-start the vehicle but start the engine using starting assistance, see

page 272. Only tow-start when the engine is cold if your vehicle has a catalytic converter.

1. Switching on hazard warning lights, please observe country-specific regulations.
2. Ignition, see page 59, on.
3. Insert 3rd gear.
4. Tow-start with the clutch depressed and release the clutch slowly. Depress the clutch again immediately after the engine starts.
5. Stop in a suitable location, remove the tow bar or towing rope and switch off the hazard warning lights.
6. Have the vehicle checked.

Do not activate the HDC, see page 100, driving mode when towing.

General care

Vehicle Equipment

This chapter describes all standard, national and special equipment provided in the model series. Therefore equipment not available in a vehicle is also described, for example the selected special equipment or national version. That also applies to safety-relevant functions and systems.

Washing the car

Notes

 Steam-jet cleaners or high-pressure cleaners

If you use steam-jet cleaners or high-pressure cleaners, make sure you maintain an adequate distance and a maximum temperature of 60 °C/140 °F.

With the glass roof keep a distance of at least 80 cm, approx. 31.5 inches. High-pressure jets striking it from close up or with excessively high pressure or temperature could cause damage, or start off a process of long-term damage.

Comply with the instructions for the high-pressure cleaner. ◀

 Cleaning sensors/cameras with high-pressure cleaners

Do not direct high-pressure cleaners at the sensors or cameras on the outside of the vehicle for sustained periods and maintain a distance of at least 30 cm, 12 in. This applies to systems such as Park Distance Control. ◀

Especially in winter, wash the car more frequently.

Very high levels of dirt and road salt can cause damage to the car.

Automatic car washes.

Notes

Bear the following in mind:

- ▷ Textile car washes or systems using soft brushes are preferable, to avoid damage to the paintwork.
- ▷ Make sure the wheels and tyres are not damaged by the conveying mechanism.
- ▷ Fold in the exterior mirrors, as they could otherwise sustain damage due to the car's width.
- ▷ Deactivate the rain sensor, see page 66, to avoid unintentional operation of the wipers.
- ▷ In some instances, depending on the interior movement detector of the alarm system, a false alarm may be triggered. Observe the notes on avoiding false alarms, see page 40.

 Guide rails in car washes
Avoid car washes where the guide rails are higher than 10 cm, 4 in as otherwise the car body may be damaged. ◀

Entering a car wash

Take the following steps so that the vehicle can be driven into a car wash:

Manual gearbox:

1. Release the parking brake.
2. Drive into the car wash.
3. Engage idle position.
4. Stop the engine.
5. Switch on ignition.

Automatic gearbox:

1. Release the parking brake, see page 63, and deactivate Automatic Hold, see page 64.
2. Drive into the car wash.

3. Depress the brake as needed.
4. Engage transmission position N.
5. Stop the engine. In this way the ignition remains switched on and a Check Control message is displayed.



Transmission position P with the ignition switched off

With the ignition switched off, transmission position P is engaged automatically. Make sure that in a car wash, for example, the ignition is not switched off inadvertently. ◀

It is not possible to lock the vehicle from the outside in transmission position N.

If an attempt is made to lock the vehicle, a signal sounds.

Transmission position

Transmission position P is automatically engaged:

- ▷ With the ignition switched off.
- ▷ After approximately 15 minutes.

Headlights

- ▷ Do not rub them when dry or use abrasive or corrosive cleaning agents.
- ▷ Soak impurities such as insects with shampoo and wash off with water.
- ▷ Remove ice with a de-icer spray; do not use an ice scraper.

After washing the car

After washing the car, drive it briefly and apply the brakes to dry them out; this is necessary to prevent reduced braking action, and also to avoid corrosion of the brake discs.

Car care

Care products

BMW recommends that you use BMW cleaning and care products, as these have been tested and approved.



Care and cleaning products

Observe the notes on the pack.

When cleaning the interior, open the doors or windows.

Use only products that are intended for cleaning the car's interior.

Cleaning agents can contain hazardous substances or constitute a health risk. ◀

Vehicle paintwork

Regular care promotes driving safety and preserves your car's value.

Environmental factors can affect the vehicle's paintwork. Base the frequency and extent of vehicle care on such factors.

Leather care

Remove dust from the leather at regular intervals with a cloth or vacuum cleaner.

Dust and road dirt will otherwise become worked into pores and folds, causing considerable abrasion and causing the leather surface to become prematurely brittle.

In order to protect against discolouration, for example from clothing, clean the leather approximately every two months.

Clean light-coloured leather more frequently as it has the tendency to soil faster.

Use leather cleaner, as dirt and grease with otherwise attack the protective coating of the leather.

Suitable cleaner can be obtained from a Service centre.

Care of upholstery fabrics

Clean regularly with a vacuum cleaner.

In the event of heavy soiling, for example stains caused by drinks, use a soft sponge or a lint-free microfibre cloth with suitable interior cleaning agents.

Clean upholstery materials over a large area up to the seams. Avoid strong rubbing.



Damage from Velcro fasteners

Open Velcro fasteners on trousers or other items of clothing can damage seat covers. Make sure that any Velcro fasteners on your clothing are closed. ◀

Care of special parts

Light alloy wheels

Apply wheel cleaner, particularly during the winter months. Do not use aggressive, acidic, strong alkali and abrasive cleaning agents, or steam-jet cleaners at above 60 °C/140 °F. Follow the manufacturer's instructions.

Chrome surfaces

Carefully clean parts such as the radiator grille and door handles with plenty of water to which a shampoo may be added, particularly if exposed to road salt.

Rubber parts

Other than washing with water, treat only with rubber care products.

Do not use any silicone-based care products for treating rubber seals, as these could otherwise be damaged and become a source of noise.

Fine wood parts

Clean fine wood trims and fine wood parts only with a damp cloth. Then dry them with a soft cloth.

Plastic parts

These include:

- ▷ Imitation leather surfaces.
- ▷ Roof lining.

- ▷ Light covers.
- ▷ Glass cover of instrument cluster.
- ▷ Parts sprayed matt black.
- ▷ Painted parts in the interior.

Use a microfibre cloth to clean.

Slightly moisten the cloth with water.

Do not soak the roof lining.



No cleaning agents containing alcohol/ solvent

Do not use any alcohol-based or solvent-based cleaning agents such as nitro thinners, cold cleansers, fuel or similar, as otherwise the surfaces can be damaged. ◀

Seat belts

Dirt on the seat belts can interfere with the action of the reel and represent a safety hazard.



Dry cleaning

Do not dry-clean or use chemical products, otherwise the fabric may be weakened. ◀

Clean only with a mild soap solution while still fitted to the car.

Never allow seat belts to retract unless they are dry.

Floor carpets and foot mats



No objects in the range of movement of the pedals

Foot mats, carpets or other objects must not breach the range of movement of the pedals, as otherwise they could influence the function of the pedals when driving.

Do not place additional foot mats on top of existing floor mats or other similar objects.

Only use foot mats that have been approved for the vehicle and that can be fastened accordingly.

Ensure that floor mats are securely reattached after having been removed, for example for cleaning. ◀

Floor mats can be removed from the car to enable the interior to be cleaned more thoroughly.

In the event of heavy soiling, clean floor carpets using a microfibre cloth and water or textile cleaner. In doing so, rub back and forth in the direction of travel, as otherwise the carpet can become tangled.

Sensors/cameras

Clean sensors or cameras using a cloth moistened with a small amount of a glass-cleaning product.

Displays/screens

Clean displays using anti-static microfibre cloth.



Cleaning of displays

Do not use any chemical or domestic cleaning agents.

Keep all liquids away from the set.

Surfaces or electrical components could otherwise be attacked or damaged.

Avoid applying excessive pressure when cleaning and do not use abrasive materials, otherwise damage could occur. ◀

Laying up out of use

Your Service centre will be pleased to advise you on the measures that should be taken if the vehicle is to be placed in storage for longer than three months.



Reference

This chapter contains the technical data, the short commands for the voice control system and the index, which provides the quickest way to find the information you need.

Technical data

Vehicle Equipment

This chapter describes all standard, national and special equipment provided in the model series.

Therefore equipment not available in a vehicle is also described, for example the selected special equipment or national version. That also applies to safety-relevant functions and systems.

Dimensions

Width, height

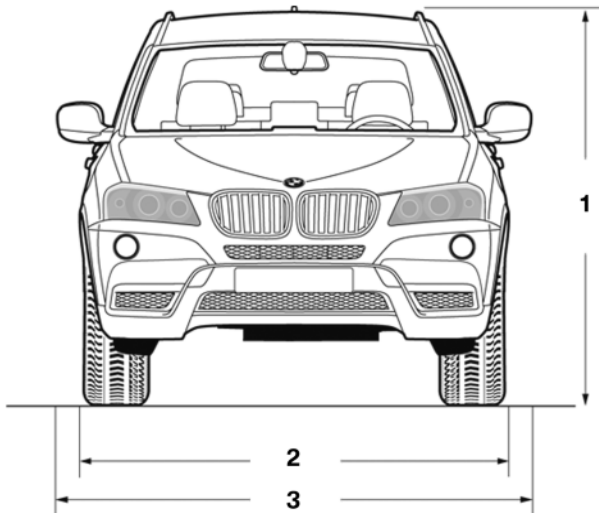

1 Vehicle height: 1675 mm

2 Vehicle width without mirrors: 1881 mm

3 Vehicle width with mirrors: 2098 mm

Length, wheelbase

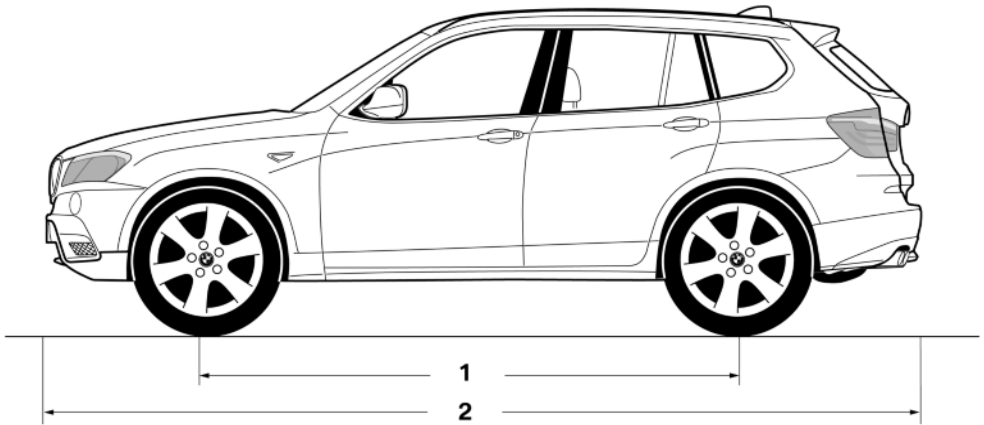

1 Wheelbase: 2810 mm

2 Vehicle length: 4648 mm

Smallest turning circle

Dia.: 11.9 m or 39 ft

Weights

Values in front of the / are for vehicles with manual transmission, values after the / are for vehicles with automatic transmission.

X3 xDrive20i		
Kerb weight, ready for road, with 75 kg, 165 lb, load, tank 90 % full, no optional extras	kg (lb)	1785/1795 (3935/3957)
Permitted gross weight	kg (lb)	2300/2310 (5070/5092)
Load	kg (lb)	590 (1300)
Front axle load limit	kg (lb)	1070 (2358)
Rear axle load limit	kg (lb)	1310 (2888)

X3 xDrive20i

Roof load	kg (lb)	100 (220)
Boot capacity	litres (cu ft)	550–1600 (19.4–56.5)

X3 xDrive28i

Kerb weight, ready for road, with 75 kg, 165 lb, load, tank 90 % full, no optional extras	kg (lb)	1795 (3957)
Permitted gross weight	kg (lb)	2310 (5092)
Load	kg (lb)	590 (1300)
Front axle load limit	kg (lb)	1080 (2380)
Rear axle load limit	kg (lb)	1290 (2843)
Roof load	kg (lb)	100 (220)
Boot capacity	litres (cu ft)	550–1600 (19.4–56.5)

X3 xDrive35i

Kerb weight, ready for road, with 75 kg, 165 lb, load, tank 90 % full, no optional extras	kg (lb)	1880 (4144)
Permitted gross weight	kg (lb)	2395 (5280)
Load	kg (lb)	590 (1300)
Front axle load limit	kg (lb)	1130 (2491)
Rear axle load limit	kg (lb)	1315 (2899)
Roof load	kg (lb)	100 (220)
Boot capacity	litres (cu ft)	550–1600 (19.4–56.5)

X3 xDrive20d

Kerb weight, ready for road, with 75 kg, 165 lb, load, tank 90 % full, no optional extras	kg (lb)	1790/1800 (3946/3968)
Permitted gross weight	kg (lb)	2305/2315 (5081/5103)
Load	kg (lb)	590 (1300)
Front axle load limit	kg (lb)	1080 (2381)
Rear axle load limit	kg (lb)	1305 (2877)
Roof load	kg (lb)	100 (220)
Boot capacity	litres (cu ft)	550–1600 (19.4–56.5)

X3 xDrive30d

Kerb weight, ready for road, with 75 kg, 165 lb, load, tank 90 % full, no optional extras	kg (lb)	1875 (4133)
Permitted gross weight	kg (lb)	2390 (5269)
Load	kg (lb)	590 (1300)
Front axle load limit	kg (lb)	1140 (2513)
Rear axle load limit	kg (lb)	1320 (2910)
Roof load	kg (lb)	100 (220)
Boot capacity	litres (cu ft)	550–1600 (19.4–56.5)

X3 xDrive35d

Kerb weight, ready for road, with 75 kg, 165 lb, load, tank 90 % full, no optional extras	kg (lb)	1925 (4243)
Permitted gross weight	kg (lb)	2440 (5379)
Load	kg (lb)	590 (1300)
Front axle load limit	kg (lb)	1160 (2557)
Rear axle load limit	kg (lb)	1320 (2910)
Roof load	kg (lb)	100 (220)
Boot capacity	litres (cu ft)	550–1600 (19.4–56.5)

Towing a trailer

Values in front of the / are for vehicles with manual transmission, values after the / are for vehicles with automatic transmission.

X3 xDrive20i

Towing loads according to EU operating permit. Your Service centre will have details of possible increases.

Unbraked	kg (lb)	750 (1653)
With brake on upward incline up to 12 %	kg (lb)	2000 (4409)
With brake on upward incline up to 12 % and increased trailer load for automatic transmission		2400 (5291)
With brake on upward incline up to 8 %	kg (lb)	2000 (4409)
With brake on upward incline up to 8 % and increased trailer load for automatic transmission		2400 (5291)
Trailer nose weight	kg (lb)	100 (220)
Rear axle load limit	kg (lb)	1460 (3218)
Permitted gross weight	kg (lb)	2400/2410 (5291/5313)

X3 xDrive28i

Towing loads according to EU operating permit. Your Service centre will have details of possible increases.

Unbraked	kg (lb)	750 (1653)
With brake on upward incline up to 12 %	kg (lb)	2000 (4409)
With brake on upward incline up to 12 % and increased trailer load for automatic transmission		2400 (5291)
With brake on upward incline up to 8 %	kg (lb)	2000 (4409)
With brake on upward incline up to 8 % and increased trailer load for automatic transmission		2400 (5291)
Trailer nose weight	kg (lb)	100 (220)
Rear axle load limit	kg (lb)	1445 (3185)
Permitted gross weight	kg (lb)	2410 (5313) 2385/2395 (5258/5280)

X3 xDrive35i

Towing loads according to EU operating permit. Your Service centre will have details of possible increases.

Unbraked	kg (lb)	750 (1653)
With brake on upward incline up to 12 %	kg (lb)	2000 (4409)
With brake on upward incline up to 12 % and increased trailer load for automatic transmission		2400 (5291)
With brake on upward incline up to 8 %	kg (lb)	2000 (4409)
With brake on upward incline up to 8 % and increased trailer load for automatic transmission		2400 (5291)
Trailer nose weight	kg (lb)	100 (220)
Rear axle load limit	kg (lb)	1470 (3240)
Permitted gross weight	kg (lb)	2495 (5500)

X3 xDrive20d

Towing loads according to EU operating permit. Your Service centre will have details of possible increases.

Unbraked	kg (lb)	750 (1653)
With brake on upward incline up to 12 %	kg (lb)	2000 (4409)
With brake on upward incline up to 12 % and increased trailer load for automatic transmission		2400 (5291)
With brake on upward incline up to 8 %	kg (lb)	2000 (4409)
With brake on upward incline up to 8 % and increased trailer load for automatic transmission		2400 (5291)
Trailer nose weight	kg (lb)	100 (220)
Rear axle load limit	kg (lb)	1460 (3218)
Permitted gross weight	kg (lb)	2405/2415 (5302/5324)

X3 xDrive30d

Towing loads according to EU operating permit. Your Service centre will have details of possible increases.

Unbraked	kg (lb)	750 (1653)
With brake on upward incline up to 12 %	kg (lb)	2000 (4409)
With brake on upward incline up to 12 % and increased trailer load for automatic transmission		2400 (5291)
With brake on upward incline up to 8 %	kg (lb)	2000 (4409)
With brake on upward incline up to 8 % and increased trailer load for automatic transmission		2400 (5291)
Trailer nose weight	kg (lb)	100 (220)
Rear axle load limit	kg (lb)	1475 (3251)
Permitted gross weight	kg (lb)	2490 (5489)

X3 xDrive35d

Towing loads according to EU operating permit. Your Service centre will have details of possible increases.

Unbraked	kg (lb)	750 (1653)
With brake on upward incline up to 12 %	kg (lb)	2000 (4409)
With brake on upward incline up to 12 % and increased trailer load for automatic transmission		2400 (5291)
With brake on upward incline up to 8 %	kg (lb)	2000 (4409)
With brake on upward incline up to 8 % and increased trailer load for automatic transmission		2400 (5291)
Trailer nose weight	kg (lb)	100 (220)
Rear axle load limit	kg (lb)	1475 (3251)
Permitted gross weight	kg (lb)	2540 (5599)

Filling capacities

	litres / Imp. units	Note
Fuel tank	67/14.7 gal	Fuel grade, see page 244
Windscreen and headlight washer system	5/8.7 pints	

Short commands of the voice control system

Vehicle Equipment

This chapter describes all standard, national and special equipment provided in the model series. Therefore equipment not available in a vehicle is also described, for example the selected special equipment or national version. That also applies to safety-relevant functions and systems.

General

Instructions for the voice control system, see page 21.

Have possible voice commands read aloud: ›Voice commands‹

Settings

Vehicle

Function	Command
Call up the main menu.	›Main menu‹
Call up options.	›Options‹
Call up settings.	›Settings‹
Information display in the instrument cluster.	›Info display‹
Control display settings.	›Control display‹
Call up time and date.	›Time and date‹
Call up language and units.	›Language and units‹
Call up speed limit.	›Speed‹
Call up lights.	›Lights‹
Call up door lock.	›Door locks‹
Call up profiles.	›Profiles‹

Equipment

Function	Command
Call up climate control.	›Climate‹
Call up Head-Up Display.	›Head up display‹

Vehicle information

Owner's Handbook

Function	Command
Call up Owner's Handbook.	›Show Owner's Handbook‹
Call up quick reference.	›Quick reference‹
Call up keyword search.	›Owner's Handbook‹
Call up search by graphics.	›Search by pictures‹

On-board computer

Function	Command
Call up on-board computer.	›On board computer‹
Call up journey computer.	›Journey computer‹

Vehicle

Function	Command
Call up vehicle information.	›Vehicle information‹
Call up vehicle status.	›Vehicle status‹

Navigation

General

Function	Command
Calls up the Navigation menu.	›Navigation‹
Call up destination input.	›Destination input‹
Entering an address.	›Destination input‹
Entering a town/city.	›City‹
Entering a country.	›Country‹
Entering the postcode	›Postcode‹

Function	Command
Call up route guidance.	›Guidance‹
Start route guidance.	›Start guidance‹
End route guidance.	›Stop guidance‹
Call up home address.	›Home address‹
Call up route criteria.	›Route criteria‹
Call up course of route.	›Route profile‹
Switch on spoken instructions.	›Switch on spoken instructions‹
Repeat spoken instructions.	›Repeat spoken instructions‹
Switch off spoken instructions.	›Switch off spoken instructions‹
Show address book.	›Address book‹
Show last destinations.	›Last destinations‹
Call up traffic information.	›Traffic information‹
Points of interest.	›Points of interest‹

Map

Function	Command
Show map.	›Map‹
Map pointing towards north.	›Map north oriented‹
Map pointing towards direction of travel.	›Map indicating direction of travel‹
Map in perspective.	›Map perspective‹
Map with automatic scaling.	›Map automatic scaling‹
Scale...metres.	›Map scale ... metres‹, for example map scale 100 metres
Scale...kilometres.	›Map scale ... kilometres‹, for example map scale 5 kilometres
Scale...miles.	›Map scale ... miles‹, for example map scale 5 miles
Scale...yards.	›Map scale ... yards‹, for example map scale 100 yards

Split screen settings

Function	Command
Split screen.	›Switch on splitscreen‹
Switch off split screen.	›Switch off splitscreen‹
Adapt split screen sizes.	›Split screen display‹
Split screen map pointing towards north.	›Splitscreen map north oriented‹
Split screen current position.	›Splitscreen current position‹
Split screen pointing towards direction of travel.	›Splitscreen map direction of travel oriented‹
Split screen perspective.	›Splitscreen perspective‹
Split screen, increased junction zoom.	›Splitscreen 3 D exit roads‹
Split screen scale...metres.	›Splitscreen scale ... metres‹, for example split screen scale 100 metres
Split screen scale...kilometres.	›Splitscreen scale ... kilometres‹, for example split screen scale 5 kilometres
Split screen scale...miles.	›Splitscreen scale ... miles‹, for example split screen scale 5 miles
Split screen scale...yards.	›Splitscreen scale ... yards‹, for example split screen scale 100 yards
Split screen, highlight traffic situation.	›Split screen, Traffic situation‹
Split screen on-board computer.	›Splitscreen on board computer‹
Split screen journey on-board computer.	›Splitscreen Journey computer‹
Automatically scale split screen.	›Splitscreen automatic scaling‹

Route guidance with intermediate destinations

Function	Command
New destination input.	›Destination input‹
Trip list.	›Saved journeys‹

Radio

FM

Function	Command
Call up station directly.	›Station ...‹ for example, Classic Radio station
Call up frequency.	›Frequency ... megahertz‹, for example 93.5 Megahertz or frequency 93.5
Call up radio.	›Radio‹
Call up FM stations.	›F M‹
Call up manual search.	›Manual search‹
Select frequency.	›Select frequency‹
Call up station.	›Select station‹

AM

Function	Command
Call up frequency.	›Frequency ... kilohertz‹, for example frequency 753 or 753 Kilohertz
Call up AM stations.	›A M‹
Call up manual search.	›Manual search‹

DAB

Function	Command
Call up station directly.	›Station ...‹, for example station B5 plus
Call up digital radio.	›D A B‹
Switch on digital radio.	›D A B on‹

Saved stations

Function	Command
Call up saved stations.	›Saved stations‹
Choose saved station.	›Select saved station‹
Select saved station.	›Saved station ...‹, for example saved station 2

CD/multimedia

CD/DVD player

Function	Command
Select track.	›Track ...‹, for example Track 5 or ›C D track ...‹, for example CD Track 5
Play CD.	›C D on‹
Select CD.	›Select C D‹
Select CD and track.	›C D ... track ...‹, for example CD 3 Track 5
Call up CD and multimedia menu.	›C D and multimedia‹
CD and DVD.	›C D‹
Select DVD.	›D V D ...‹ for example DVD 3
Show entertainment details in split screen.	›Entertainment details‹

Music collection

Function	Command
Call up music search, menu.	›Music search‹
Call up current playback.	›Current playback‹
Call up music collection.	›Music collection‹
Play music collection.	›Music collection on‹
Play most played tracks.	›Top fifty‹

External devices

Function	Command
Call up external devices.	›External devices‹
Call up Bluetooth devices.	›Bluetooth‹
AUX front.	›AUX front‹

TV

Function	Command
Call up TV.	›T V‹

Sound

Function	Command
Call up sound.	›Tone‹

Telephone

Function	Command
Dial phone number.	›Dial number‹
Calls up the Telephone menu.	›Telephone‹
Show phonebook.	›Phonebook‹
Redialling.	›Redial‹
Show missed calls.	›Received calls‹
List of messages.	›Messages‹
Call up Bluetooth devices.	›Bluetooth‹

Office

Function	Command
Call up office menu.	›Office‹
Show office update.	›Office today‹
Show contacts.	›Contacts‹
Show messages.	›Messages‹
Show calendar.	›Calendar‹
Show tasks.	›Tasks‹
Show reminders.	›Reminders‹

Contacts

Function	Command
Select name.	›Select name‹
My contacts.	›My contacts‹
Call up contacts.	›Contacts‹
New contact.	›New contact‹

BMW Service or ConnectedDrive

Function	Command
Call up BMW services.	›B M W Services‹
Call up connected drive.	›Connected Drive‹
Call up BMW Online.	›B M W Online‹
Call up Internet.	›Internet‹

From A to Z

Index

A

- ABS, anti-lock braking system [99](#)
- Accessories and parts [7](#)
- Activating/deactivating Bluetooth link [209](#)
- Activation, airbags [94](#)
- Adaptive brake light, see Dynamic brake lights [98](#)
- Adaptive Headlights [88](#)
- Additional telephone [208](#)
- Additives, oil [257](#)
- After washing the car [278](#)
- Age of tyres [247](#)
- Airbags [92](#)
- Airbags, indicator/warning light [93](#)
- Airbag switch, see Key switch for front passenger airbags [94](#)
- Air conditioning [118](#), [120](#)
- Air distribution, manual [118](#), [121](#)
- Air flow, automatic air conditioning [119](#), [121](#)
- Air outlets, see Ventilation [123](#)
- Air pressure, tyres [246](#)
- Alarm, false [40](#)
- Alarm system [39](#)
- ALL program, automatic air conditioning [122](#)
- All-season tyres, see Winter tyres [248](#)
- Alternating-code hand-held transmitter [126](#)
- Alternative oil grades [258](#)
- AM-/FM stations [176](#)
- Anti-freeze protection, washer fluid [68](#)
- Anti-lock braking system, ABS [99](#)
- Anti-theft alarm system, see Alarm system [39](#)
- Anti-theft device, see Central locking system [31](#)
- Anti-theft system, wheel studs [268](#)
- Anti-trap mechanism, glass roof [42](#)
- Anti-trap mechanism, windows [41](#)
- Applications [237](#)
- Appointments [224](#)
- Apps [237](#)
- Apps, video playback [196](#)
- Aquaplaning [139](#)
- Armrest, see Centre armrest [132](#)
- Around the centre console [12](#)
- Around the headlining [13](#)
- Around the steering wheel [10](#)
- Arrival time [82](#)
- Assist, BMW [230](#)
- AUC, automatic air recirculation control [122](#)
- Audio playback, Bluetooth [197](#)
- AUTO H button, see Automatic Hold [64](#)
- AUTO intensity [121](#)
- Automatic air conditioning [118](#)
- Automatic air conditioning with extended functionality [120](#)
- Automatic air recirculation control, AUC [122](#)
- Automatic anti-glare control, see High-beam assistance [88](#)
- Automatic driving lights control [87](#)
- Automatic Hold [64](#)
- Automatic locking [35](#)
- Automatic tailgate [36](#)
- Automatic transmission with Steptronic [68](#)
- AUTO program, air conditioner [119](#)
- AUTO program, automatic air conditioning [121](#)
- AUTO program, intensity [121](#)
- Auto Start Stop function [61](#)
- AUX-IN port [193](#)
- Average fuel consumption [81](#)
- Average speed [81](#)
- Avoiding routes [163](#)
- Axle load limit [285](#)
- Axle loads, weight [285](#)

B

- Backrest contour, see Lumbar support [46](#)
- Backrest width [46](#)
- Balance [174](#)
- Bar for tow-starting/towing [275](#)
- Bass [174](#)
- Battery, vehicle [269](#)
- Being towed, see Tow-starting/towing [274](#)
- Belts, seat belts [47](#)
- Block, power windows [41](#)
- Blower, see Air flow [119](#), [121](#)
- Bluetooth audio [197](#)
- BMW Assist [230](#)
- BMW homepage [6](#)
- BMW internet site [6](#)
- BMW Maintenance System [260](#)

BMW Online [232](#)
 BMW TeleServices [230](#)
 Bonnet [254](#)
 Boot [128](#)
 Boot cover [128](#)
 Boot lid [35](#)
 Boot, storage space [134](#)
 Bottle holder, see Cupholder [133](#)
 Brake assist [99](#)
 Brake lights, adaptive [98](#)
 Brake lights, dynamic [98](#)
 Braking, notes [140](#)
 Braking safely [140](#)
 Breakdown Assist [271](#)
 Breakdown assistance [231](#)
 Breakdown service, Mobile Service [272](#)
 Breakdown, wheel change [268](#)
 Brightness of the control display [84](#)
 Bulb replacement [264](#)
 Bulbs [86](#)
 Button, AUTO H [64](#)
 Buttons on the steering wheel [10](#)
 Button, start/stop [59](#)
 Bypassing a section of the route [164](#)

C

Calendar [224](#)
 Camera, rear-view camera [114](#)
 Cameras, care [280](#)
 Camera, Top View [115](#)
 Car care [278](#)
 Care products [278](#)
 Care, vehicle [278](#)
 Car jack [268](#)
 Car key, see Remote control [28](#)
 Carpet, care [279](#)
 Carrying children in safety [54](#)

Car washes [277](#)
 Catalytic converter, see Hot exhaust system [139](#)
 CBS, Condition Based Service [260](#)
 CD/DVD [181](#)
 CD memory [188](#)
 Central key, see Remote control [28](#)
 Central locking system [31](#)
 Central screen, see Control display [14](#)
 Centre armrest [132](#)
 Centre console [12](#)
 Changes, technical, see Your own safety [7](#)
 Changing the scale in navigation system [166](#)
 Charcoal canister [122](#)
 Check Control [73](#)
 Child locks [58](#)
 Children, carrying [54](#)
 Child restraint systems [54](#)
 Child seat classes, ISOFIX [55](#)
 Child seat mounting [54](#)
 Child seat mountings, ISOFIX [55](#)
 Child's seats [54](#)
 Chrome parts, care [279](#)
 City input, navigation [155](#)
 Climate comfort wind-screen [139](#)
 Clock [76](#)
 Closing/opening from inside [35](#)
 Closing/opening via door lock [34](#)
 Closing/opening with remote control [32](#)
 Coat hooks [133](#)
 Cold start, see Engine start [60](#)
 Comfort Access [37](#)
 Comfort closing [33](#)
 Comfort opening [32](#)

COMFORT program, driving dynamics [103](#)
 Compressor [250](#)
 Computer, see On-board computer [80](#)
 Condensate under the vehicle [141](#)
 Condensation on windows [119](#), [122](#)
 Condition Based Service, CBS [260](#)
 Confirmation signals [33](#)
 Contacts [219](#), [0](#)
 Control display [14](#)
 Control display, settings [83](#)
 Controller [14](#)
 Control systems, driving stability [99](#)
 Coolant [259](#)
 Coolant temperature [75](#)
 Cooling effect, maximum [121](#)
 Cooling function [119](#), [122](#)
 Cooling system [259](#)
 Corrosion of brake discs [140](#)
 Country selection, navigation [154](#)
 Course of route [164](#)
 Cruise Control [106](#)
 Cupholder [133](#)
 Current fuel consumption [77](#)

D

DAB, digital radio [178](#)
 Damage, tyres [247](#)
 Damper Control, dynamic [101](#)
 Data, technical [284](#)
 Date [76](#)
 Daytime driving lights [87](#)
 Deactivation, airbags [94](#)
 Defrosting, see Defrosting windows [119](#), [122](#)
 Defrosting windows [119](#), [122](#)
 Defrost, see Defrosting windows [119](#), [122](#)

- Destination input, navigation [154](#)
- Diesel fuel [244](#)
- Diesel particle filter [139](#)
- Digital clock [76](#)
- Digital radio, DAB/DMB [178](#)
- Dimensions [284](#)
- Dimmable exterior mirrors [52](#)
- Dimming interior mirror [52](#)
- Dipping headlights, see High-beam assistance [88](#)
- Display cleaning [280](#)
- Displaying the route [164](#)
- Display in windscreen [116](#)
- Display lighting, see Instrument lighting [90](#)
- Display of faults, see Check Control [73](#)
- Displays [71](#)
- Displays, care [280](#)
- Displays, cleaning [280](#)
- Displays, electronic, instrument cluster [72](#)
- Disposal, coolant [259](#)
- Disposal, vehicle battery [269](#)
- Distance to destination [81](#)
- Distance warning, see PDC [109](#)
- DMB, digital radio [178](#)
- Door key, see Remote control [28](#)
- Door lock [34](#)
- Downhill gradients [140](#)
- Drinks holder, see Cupholder [133](#)
- Drive experience switch [102](#)
- Driving hints [138](#)
- Driving into a car wash [277](#)
- Driving lane lines, rear-view camera [112](#)
- Driving lights control, automatic [87](#)
- Driving notes, general [138](#)
- Driving notes, running in [138](#)
- Driving stability control systems [99](#)
- Drying air, see Cooling function [119](#), [122](#)
- DSC Dynamic Stability Control [99](#)
- DTC, Dynamic Traction Control [100](#)
- DVD/CD [181](#)
- DVD changer [185](#)
- DVD settings [184](#)
- DVD, video [183](#)
- Dynamic brake lights [98](#)
- Dynamic Damper Control [101](#)
- Dynamic route guidance [170](#)
- Dynamic Stability Control, DSC [99](#)
- Dynamic Traction Control, DTC [100](#)
- ## E
- ECO PRO [149](#)
- ECO PRO display [149](#)
- ECO PRO mode [149](#)
- EfficientDynamics [150](#)
- EfficientDynamics menu [150](#)
- EfficientDynamics menu, see ECO PRO [149](#)
- Electrical power windows [40](#)
- Electric steering wheel lock [53](#)
- Electronic displays, instrument cluster [72](#)
- Electronic oil level check [256](#)
- Electronic Stability Program, ESP, see DSC [99](#)
- Emergency call [271](#)
- Emergency detection, remote control [29](#)
- Emergency release, fuel filler flap [242](#)
- Emergency service, see Mobile Service [272](#)
- Emergency start function, engine start [29](#)
- Emergency unlocking, door lock [34](#)
- Energy Control [77](#)
- Energy recuperation [77](#)
- Engine, automatic shutoff [61](#)
- Engine, automatic start-stop function [61](#)
- Engine compartment [254](#)
- Engine coolant [259](#)
- Engine oil [256](#)
- Engine oil additives [257](#)
- Engine oil change [258](#)
- Engine oil filler neck [257](#)
- Engine oil grades, alternative [258](#)
- Engine oil grades, approved [257](#)
- Engine oils, approved [257](#)
- Engine oil temperature [75](#)
- Engine start [60](#)
- Engine start with malfunction [29](#)
- Engine temperature [75](#)
- Entering letters and digits [19](#)
- Equaliser [174](#)
- Equipment, interior [125](#)
- ESP, Electronic Stability Program, see DSC [99](#)
- Exhaust system [139](#)
- Extended BMW Online services [239](#)
- Exterior mirror, automatically dimming [52](#)
- Exterior mirrors [51](#)
- External devices [193](#)
- External starting [272](#)
- Eye for towing, see Towing eye [275](#)
- Eyes for securing load [142](#)
- ## F
- Fader [174](#)
- Failure message, see Check Control [73](#)
- False alarm [40](#)
- Fastening seat belts, see Seat belts [47](#)

Favourites buttons, iDrive [19](#)
Filler neck for engine oil [257](#)
Fine wood, care [279](#)
First-aid kit [272](#)
Flat tyre, warning lamp [95](#)
Flooding [139](#)
Floor carpet, care [279](#)
FM-/AM stations [176](#)
Fog lights, replacing bulbs [266](#)
Fold-out position, windscreen wipers [67](#)
Foot brake [140](#)
Foot mats, care [279](#)
Four-wheel drive [100](#)
Front airbags [92](#)
Front fog lights [90](#)
Front head restraints [49](#)
Front lights [264](#)
Front neck supports, see Head restraints [49](#)
Front passenger airbags, deactivating/activating [94](#)
Front passenger airbags, light [94](#)
Fuel consumption, see Average fuel consumption [81](#)
Fuel filler flap [242](#)
Fuel gauge [75](#)
Fuel grade [244](#)
Fuel tank cap [242](#)
Fuel, tank capacity [292](#)
Fuse [270](#)

G

Garage door opener, see Integrated universal remote control [125](#)
Gearbox, manual gearbox [68](#)
Gear change, automatic transmission [69](#)
Gearshift, automatic transmission [68](#)
General driving notes [138](#)

Glass roof, see Panorama glass roof [41](#)
Glove box [131](#)
Gong, speaker equalisation [175](#)
GPS navigation [154](#)
Green diesel [244](#)
Guided tour [162](#)

H

Handbrake, see Parking brake [63](#)
Hand-held transmitter, alternating-code [126](#)
Hazard warning lights [271](#)
HDC Hill Descent Control [100](#)
Head airbags [92](#)
Head Light [88](#)
Headlight courtesy delay feature [87](#)
Headlight flasher [65](#)
Headlight flasher, replacing bulbs [265](#)
Headlight lens [264](#)
Headlights [264](#)
Headlights, care [278](#)
Headlight washer system [66](#)
Headlining [13](#)
Head restraints [44](#)
Head-Up Display [116](#)
Head-Up Display, care [280](#)
Heated rear window [120](#), [122](#)
Heavy transported load, loading [142](#)
Height, vehicle [284](#)
High-beam assistance [88](#)
High-beam headlights [65](#)
High-beam headlights, replacing bulbs [265](#)
Hill Descent Control HDC [100](#)
Hints [6](#)
Homepage [6](#)
Horn [10](#)
Hot exhaust system [139](#)
Hotline [235](#)

House number, input for navigation [155](#)
HUD Head-Up Display [116](#)

I

Ice warning, see Outside temperature warning [76](#)
Icy roads, see Outside temperature warning [76](#)
Identification number, see Important to Know in the Engine Compartment [254](#)
iDrive [14](#)
Ignition key, see Remote control [28](#)
Ignition off [59](#)
Ignition on [59](#)
Important considerations [54](#)
Important information regarding the engine compartment [254](#)
Importing a trip, online [162](#)
Importing a trip, USB [162](#)
Independent ventilation [123](#)
Indication of a flat tyre [95](#)
Indicators, see Turn indicators [65](#)
Individual air distribution [118](#), [121](#)
Individual settings, see Personal Profile [29](#)
Inflation pressure, tyres [246](#)
Inflation pressure warning, tyres [95](#)
Info Display, see On-board computer [80](#)
Information on navigation data [170](#)
Information on no passing [78](#)
Information on speed limit [78](#)
Information service [230](#)
Initialising, runflat indicator, RPA [95](#)
Instrument cluster [71](#)

Instrument cluster, electronic displays [72](#)
Instrument cluster switch, see Turn indicators [65](#)
Instrument cluster switch, see Wiper system [66](#)
Instrument lighting [90](#)
Integrated key [28](#)
Integrated universal remote control [125](#)
Intensity, AUTO program [121](#)
Interactive map [159](#)
Interior equipment [125](#)
Interior light [90](#)
Interior lights via remote control [33](#)
Interior mirror [52](#)
Interior mirror, automatic-dim [52](#)
Interior movement detector [40](#)
Intermediate destinations [161](#)
Internet [233](#)
Internet site [6](#)
Interval display, service requirement [77](#)
iPod/iPhone [194](#)
ISOFIX child seat mountings [55](#)

J

Jack mounting points [268](#)
Journey computer [82](#)
Joystick, automatic transmission [69](#)
Jump-starting connection, starting assistance [273](#)
Jump starting, see starting assistance [272](#)
Junction, entering for navigation [155](#)

K

Key/remote control [28](#)

Keyless Go, see Comfort Access [37](#)
Key memory, see Personal Profile [29](#)
Key switch for front passenger airbags [94](#)
Kick-down, automatic transmission [69](#)

L

Label, run-flat tyres [249](#)
Lane boundary, warning [97](#)
Lane departure warning [97](#)
Language, on the control display [84](#)
Lashing eyes, securing load [142](#)
Lashing straps, securing load [142](#)
Laying up out of use [280](#)
Laying up, vehicle [280](#)
Leather, care [278](#)
LEDs, light-emitting diodes [264](#)
Left-hand traffic, light setting [90](#)
Length, vehicle [285](#)
Light alloy wheels, care [279](#)
Light-emitting diodes, LEDs [264](#)
Lighting [86](#)
Lighting via remote control [33](#)
Lights [264](#)
Light switch [86](#)
Loads [142](#)
Lock, door [34](#)
Locking/unlocking from inside [35](#)
Locking/unlocking via door lock [34](#)
Locking/unlocking with remote control [32](#)
Locking, automatic [35](#)
Locking, central [31](#)

Locking, doors and windows [58](#)
Locking via the tailgate [36](#)
Lock, wheel studs [268](#)
Low-beam headlights [86](#)
Lower back support [46](#)
Luggage net [129](#)
Luggage rack, see Roof rack [141](#)
Lumbar support [46](#)

M

Maintenance [260](#)
Maintenance requirement [260](#)
Maintenance, service requirement [77](#)
Maintenance System BMW [260](#)
Malfunction displays, see Check Control [73](#)
Manual air distribution [118](#), [121](#)
Manual air flow [119](#), [121](#)
Manual gearbox [68](#)
Manual operation, door lock [34](#)
Manual operation, exterior mirrors [51](#)
Manual operation, fuel filler flap [242](#)
Manual operation, Park Distance Control, PDC [110](#)
Manual operation, rear-view camera [111](#)
Manual operation, Top View [114](#)
Manual operation, transmission [69](#)
Map, destination input [159](#)
Map in the split screen [167](#)
Map view [165](#)
Markings on approved tyres [248](#)
Maximum cooling effect [121](#)

Memory, seat, mirror [50](#)
Menu in the instrument cluster [80](#)
Menus, see iDrive operating principle [15](#)
Message list, traffic information [168](#)
Messages [221](#)
Microfilter [120](#), [122](#)
Minimum tread depth, tyres [247](#)
Mirror, memory [50](#)
Mirrors [51](#)
Mobile communication equipment [139](#)
Mobile phone [208](#)
Mobile Service [272](#)
Mobility system [250](#)
Moisture in the headlight [264](#)
Monitor, see Control display [14](#)
Mounting child restraints [54](#)
MP3 player [193](#)
Multifunction steering wheel, buttons [10](#)
Multimedia [181](#)
Music collection [188](#)
Music memory [188](#)
Music search [189](#)

N

Navigation [154](#)
Navigation announcement, see Voice instructions [165](#)
Navigation data [170](#)
New wheels and tyres [248](#)
No Passing Information [78](#)
Nose weight [288](#)
Notes [225](#)
Notes regarding CD/DVD [187](#)
Nylon ropes for tow-starting/towing [275](#)

O

OBD on-board diagnosis [262](#)
Obstacle marking, rear-view camera [113](#)
Octane number, see Petrol grade [244](#)
Odometer [76](#)
Office [218](#)
Oil [256](#)
Oil additives [257](#)
Oil change [258](#)
Oil change interval, service requirement [77](#)
Oil filler neck [257](#)
Oil grades, alternative [258](#)
Oil grades, approved [257](#)
Oil grades, prescribed [257](#)
Oil level check [256](#)
Old battery, disposing [269](#)
On-board computer [80](#)
On-board diagnosis, OBD [262](#)
On-board monitor, see Control display [14](#)
On-board tool kit [263](#)
Online, see BMW Online [232](#)
Opening/closing from inside [35](#)
Opening/closing via door lock [34](#)
Opening/closing with remote control [32](#)
Operating menus, iDrive [14](#)
Operating principle, iDrive [14](#)
Outside air, see AUC [122](#)
Outside temperature display [76](#)
Outside temperature warning [76](#)
Overheating of the engine, see Coolant temperature [75](#)

P

Paintwork, vehicle [278](#)

Panorama glass roof [41](#)
Park Distance Control, PDC [109](#)
Parked vehicle, condensate [141](#)
Parking aid, see PDC [109](#)
Parking brake [63](#)
Parking lights [87](#)
Parking position [51](#)
Parking with Auto Hold [64](#)
Particle filter [139](#)
Part replacement [263](#)
Parts and accessories [7](#)
Passenger's mirror, tilting down [51](#)
PDC Park Distance Control [109](#)
Performance Control [100](#)
Permitted gross weight while towing a trailer [288](#)
Personal information [218](#)
Personal Profile [29](#)
Petrol [244](#)
Petrol grade [244](#)
Place for children [54](#)
Plasters, see First-aid kit [272](#)
Plastic, care [279](#)
Playing audio tracks [182](#)
PlugIn [237](#)
Pockets in the doors [132](#)
Points of interest, navigation [157](#)
Postcode input, navigation [155](#)
Power failure [269](#)
Power socket [127](#)
Power windows [40](#)
Pressure, tyres [246](#)
Pressure warning, tyres [95](#)
Profiles, Personal Profile [29](#)
Protection function, glass roof [42](#)
Protection function, windows [41](#)
Puncture, runflat indicator, RPA [95](#)

R

Radio [176](#)
Radio-control key, see Remote control [28](#)
Radio ready state [60](#)
Radio signals [139](#)
Rain sensor [66](#)
Random [182](#)
Random playback [182](#)
Range [76](#)
Rape seed methyl ester, RME [244](#)
RDS [177](#)
Readiness service, see Mobile Service [272](#)
Reading out [226](#)
Rear fog lights [90](#)
Rear head restraints [49](#)
Rear lights [267](#)
Rear neck supports, see Head restraints [49](#)
Rear-view camera [111](#)
Recirculated-air mode [119](#), [122](#)
Recirculating air filter [122](#)
Recirculation, see Recirculated-air mode [119](#), [122](#)
Recommended tours [162](#)
Recommended tyre makes [248](#)
Recycling [262](#)
Refuelling [242](#)
Refuelling recommendation [165](#)
Regional programmes [177](#)
Registering, mobile [209](#)
Register mobile [209](#)
Remaining distance [76](#)
Remedying punctures [249](#)
Reminders [225](#)
Remote control/key [28](#)
Remote control, malfunction [34](#)
Remote control, universal [125](#)
Rename station [177](#)

Replacement fuse [270](#)
Replacement of parts [263](#)
Replacement of wheels/tyres [248](#)
Replacing bulbs [264](#)
Replacing bulbs, front [264](#)
Replacing bulbs, rear [267](#)
Replacing parts [263](#)
Replacing the battery, vehicle battery [269](#)
Replacing the battery, vehicle remote control [28](#)
Replacing wiper blades [263](#)
Reserve warning, see Range [76](#)
Restraint systems for children [54](#)
Retreaded tyres [248](#)
Reuse [262](#)
Revolution counter [75](#)
Right-hand traffic, light setting [90](#)
RME, rape seed methyl ester [244](#)
Roller cover [128](#)
Roller sunblinds [41](#)
RON petrol grade [244](#)
Roof load [285](#)
Roof rack [141](#)
Rope for tow-starting/towing [275](#)
Route criteria, route [163](#)
Route guidance [163](#)
Route guidance with intermediate destinations [161](#)
RPA, runflat indicator [95](#)
RSC Runflat System Component, see Run-flat tyres [249](#)
Rubber parts, care [279](#)
Runflat indicator, RPA [95](#)
Run-flat tyres [249](#)
Running in [138](#)
Running in brake discs [138](#)
Running in brake pads [138](#)
Run up warning [105](#)

S

Safe seated position [44](#)
Safety switch, windows [41](#)
Safety systems, airbags [92](#)
Saved stations [180](#)
Saving current position [156](#)
Saving DVDs [188](#)
Saving fuel [0](#)
Saving position [156](#)
Saving settings for seat, mirror [50](#)
Saving stations [176](#)
Screen, see Control display [14](#)
Screwdriver [263](#)
Screw thread for towing eye [276](#)
Sealing compound [250](#)
Seat and mirror memory [50](#)
Seat belt reminder for driver's and front passenger's seat [48](#)
Seat belts [47](#)
Seat belts, care [279](#)
Seat heating, front [47](#)
Seat heating, rear [47](#)
Seats [44](#)
Selection list in the instrument cluster [80](#)
Selector lever, automatic transmission [69](#)
Sensors, care [280](#)
Service, Mobile [272](#)
Service partners [236](#)
Service requirement, Condition Based Service CBS [260](#)
Service requirement, display [77](#)
Settings on the control display [83](#)
Settings, seats/head restraints [44](#)
Shift paddle on the steering wheel [70](#)
Shift point indicator [78](#)

- Short commands [293](#)
Side airbags [92](#)
Side lights [86](#)
Side lights, replacing
bulbs [265](#)
Signals on unlocking [33](#)
Sliding/tilting roof [41](#)
Smallest turning circle [285](#)
Snap-in adapter, mobile
phone [217](#)
Snow chains [252](#)
Socket in rear passenger com-
partment [127](#)
Socket, on-board diagnosis
OBD [262](#)
Software applications,
iPhone [237](#)
Software update, update soft-
ware [200](#)
Soot particle filter [139](#)
Sound [174](#)
Spare fuse [270](#)
Special equipment, standard
equipment [6](#)
Speed, displaying maxi-
mum [78](#)
Speed Limit Information [78](#)
Speed limit information, on-
board computer [82](#)
Speed limit in on-board com-
puter [82](#)
Speed Volume, speaker equal-
isation [175](#)
Split screen [18](#)
Split screen map settings [167](#)
Split screen view, split
screen [18](#)
SPORT+ program, driving dy-
namics [102](#)
Sport automatic transmis-
sion [70](#)
SPORT program, driving dy-
namics [103](#)
Sport program, transmis-
sion [69](#)
Sports steering, variable [102](#)
Stability control systems [99](#)
Start/stop button [59](#)
Start function with malfunc-
tion [29](#)
Starting assistance [272](#)
Starting assistance, see
DSC [99](#)
Starting, see Engine start [60](#)
Starting the engine [60](#)
Starting the engine, starting
assistance [272](#)
Stations AM-/FM [176](#)
Status information, iDrive [17](#)
Status of the Owner's
Handbook [6](#)
Steering wheel, adjusting [53](#)
Steering wheel heating [53](#)
Steptronic, automatic trans-
mission [68](#)
Stopping the engine [60](#)
Storage compartments [131](#)
Storage options [131](#)
Storage, tyres [249](#)
Storage, vehicle [280](#)
Street, entering for naviga-
tion [155](#)
Summer tyres, tread [247](#)
Sunblinds, sun guard [41](#)
Supplementary text mes-
sages [74](#)
Swinging of the trailer, see
Trailer Stability Control [146](#)
Switches, see Driving area [10](#)
Switch for driving dynam-
ics [102](#)
Switching off the engine [60](#)
Switch-on times, independent
ventilation [124](#)
Symbols [6](#)
Symbols used [6](#)
- T**
- Tailgate [35](#)
Tailgate, automatic [36](#)
Tailgate via remote control [33](#)
Tail lights [267](#)
Tank display [75](#)
Tasks [224](#)
Technical changes, see Your
own safety [7](#)
Technical data [284](#)
Telephone [208](#)
TeleServices [230](#)
Television, TV [202](#)
Temperature, automatic air
conditioning [119](#), [121](#)
Temperature display, outside
temperature [76](#)
Temperature, engine oil [75](#)
Tensioning bands, securing
load [142](#)
Text messages [221](#)
Text messages, supplemen-
tary [74](#)
The map is shown in grey [169](#)
Theftproof wheel studs [268](#)
Thigh support [46](#)
Tilt alarm sensor [40](#)
Tilting down, passenger's mir-
ror [51](#)
Toll routes, route [163](#)
Tools [263](#)
Topping up engine oil [257](#)
Top speed, winter tyres [249](#)
Top View [114](#)
Total weight [285](#)
Total weight, permitted [285](#)
Tourist function, see Left-
hand/right-hand traffic [90](#)
Towing [274](#)
Towing eye [275](#)
Towing truck [275](#)
Tow-starting [274](#)
TP, traffic announce-
ments [180](#)
Traction control [100](#)
TRACTION program, driving
dynamics [100](#)
Traffic information, Naviga-
tion [168](#)
Traffic reports [180](#)

Trailer loads [288](#)
Trailer Stability Control [146](#)
Trailer tow hitch [146](#)
Trailer towing, data [288](#)
Transmission [68](#)
Transmission, automatic [68](#)
Tread, tyres [247](#)
Treble, sound [174](#)
Trip distance recorder [76](#)
Triple turn signal [65](#)
Turn indicators, operation [65](#)
Turning circle [285](#)
Turning circle lines, rear-view camera [112](#)
TV [202](#)
Tyre damage [247](#)
Tyre pressure monitoring, see RPA [95](#)
Tyre pressures [246](#)
Tyre replacement [248](#)
Tyre sealant [250](#)
Tyres, everything about wheels and tyres [246](#)
Tyre tread [247](#)

U

Units of measure [84](#)
Universal remote control [125](#)
Unloaded weight [285](#)
Unlock button, automatic transmission [69](#)
Unlocking/locking from inside [35](#)
Unlocking/locking via door lock [34](#)
Unlocking/locking with remote control [32](#)
Updates after going to press [7](#)
Upholstery care [278](#)
USB audio interface [194](#)
USB interface [132](#)

V

Variable sports steering [102](#)
Vehicle battery [269](#)
Vehicle battery, changing [269](#)
Vehicle equipment [6](#)
Vehicle for tow-starting/towing [275](#)
Vehicle identification number, see Identification number in the engine compartment [254](#)
Vehicle paintwork [278](#)
Vehicle, running in [138](#)
Ventilation [123](#)
Ventilation, see Independent ventilation [123](#)
Version of navigation data [170](#)
Video playback, iPhone [196](#)
Video playback, snap-in adapter [196](#)
Video replay [183](#)
Voice control, short commands [293](#)
Voice control system [21](#)
Voice instructions, navigation [165](#)
Volume, adjusting [174](#)

W

Wading [139](#)
Warning messages, see Check Control [73](#)
Warning triangle [272](#)
Washer fluid [68](#)
Washer fluid tank, capacity [292](#)
Washer jets, windows [67](#)
Washing the car [277](#)
Water on roads [139](#)
Weights [285](#)
Welcome lights [86](#)
Wheelbase, vehicle [285](#)
Wheel change [268](#)

Wheel replacement [248](#)
Wheels, everything about wheels and tyres [246](#)
Wheels, runflat indicator, RPA [95](#)
Width, vehicle [284](#)
Windscreen washer jets [67](#)
Windscreen washing system [66](#)
Windscreen wipers [66](#)
Windscreen wipers, fold-out position [67](#)
Winter-grade diesel [244](#)
Winter storage, care and maintenance [280](#)
Winter tyres, right tyres [248](#)
Winter tyres, tread [247](#)
Wiper system [66](#)
Wood, care [279](#)
Wordmatch principle, navigation [19](#)
Working in the engine compartment [254](#)
Wrench [263](#)

X

xDrive [100](#)
Xenon light, replacing bulbs [265](#)

Y

Your own safety [7](#)

More about BMW



The Ultimate Driving
Machine

www.bmw.com

01 40 2 900 867 en



Online Edition for Part no. 01 40 2 900 867 - 03 12 490